

SECTION E

SECTION D

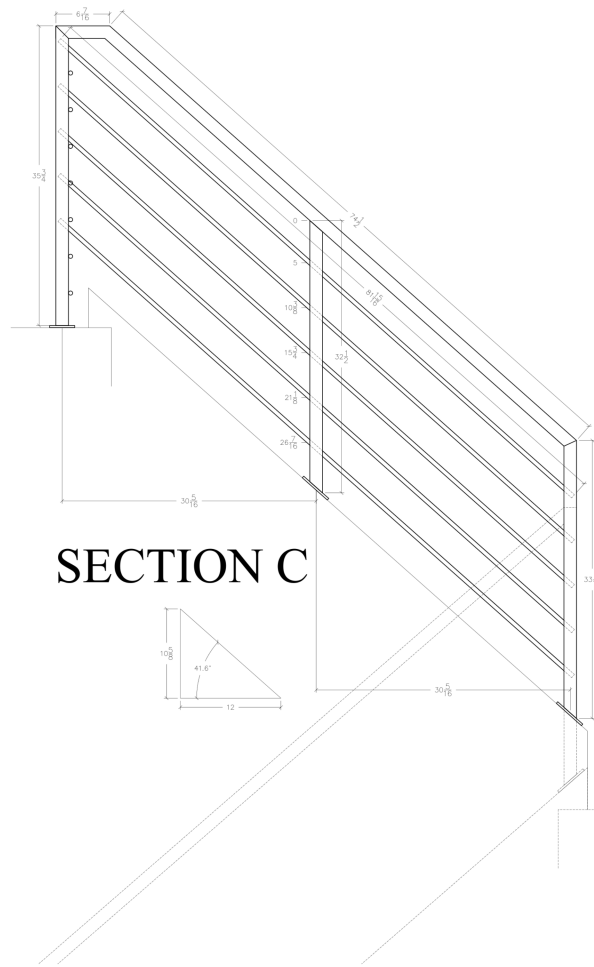

SECTION C

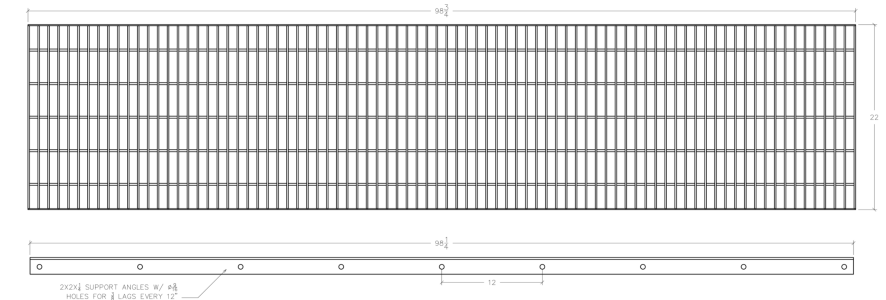

GRATING

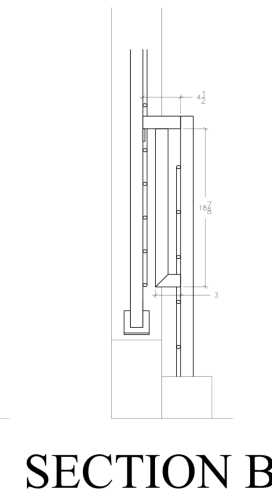

SECTION B

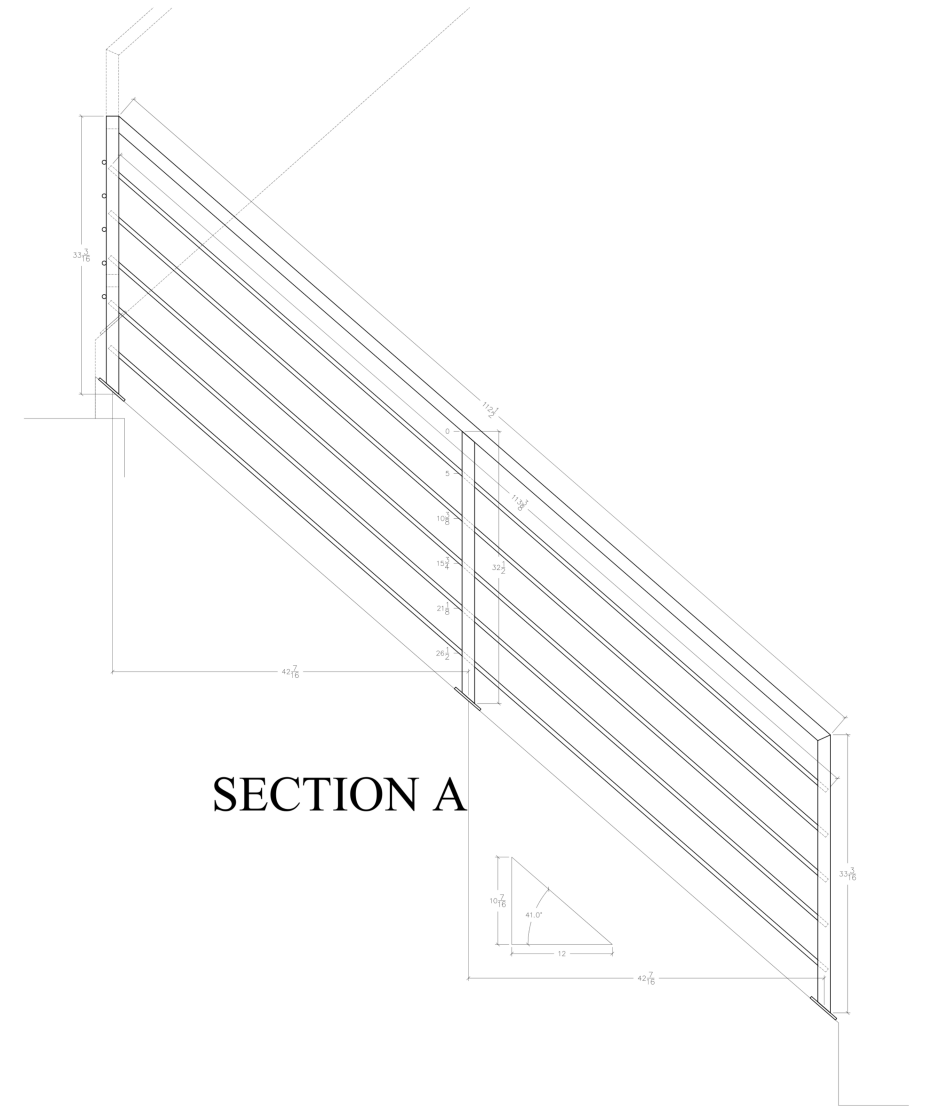

SECTION A

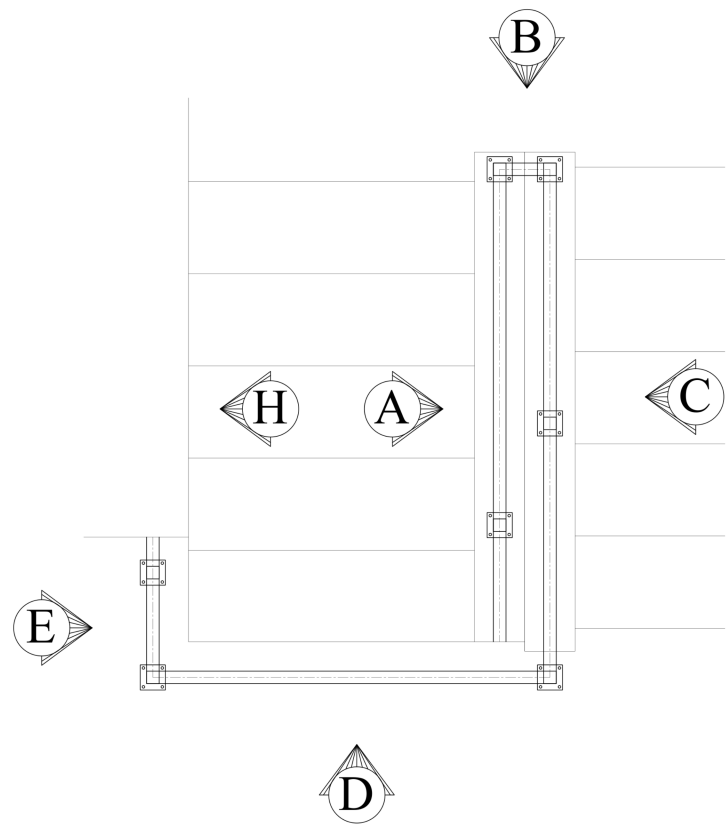

SECTION H

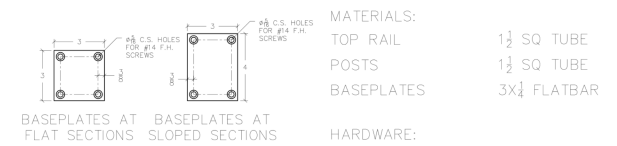

MATERIALS:
 TOP RAIL 1 1/2 SQ TUBE
 POSTS 1 1/2 SQ TUBE
 BASEPLATES 3x3 FLATBAR

HARDWARE:
 #14 F.H. SCREWS QTY 40
 1/2-20 F.H. SCREWS QTY 6

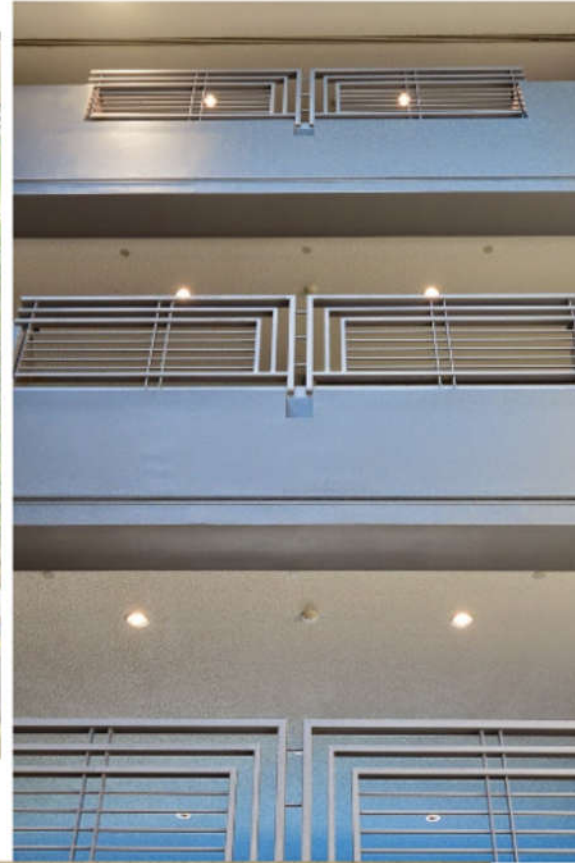
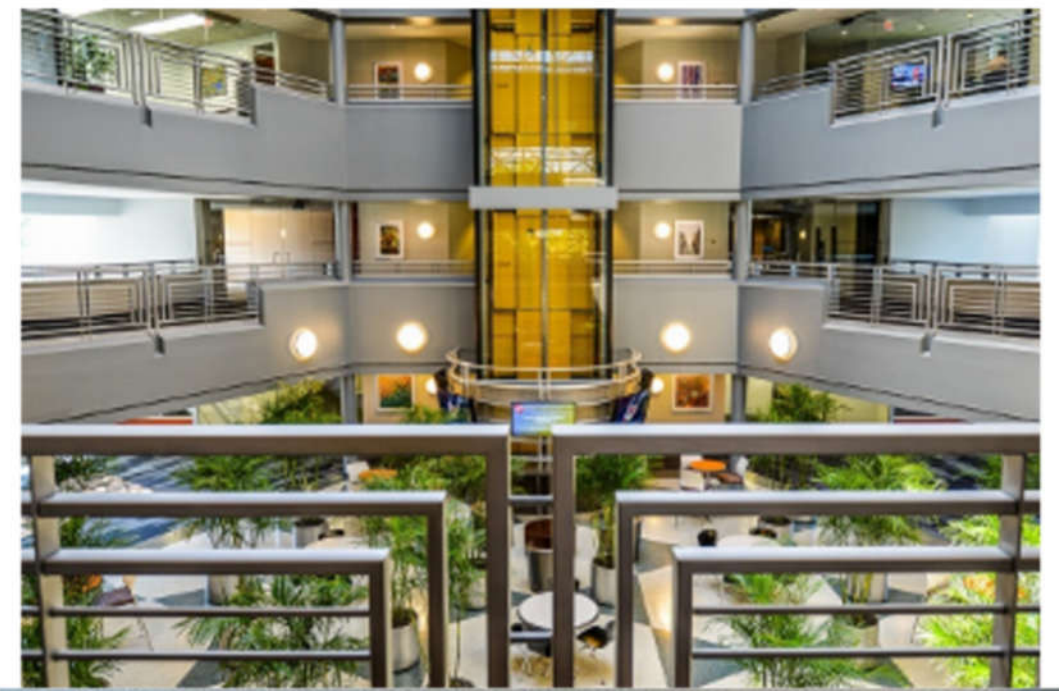

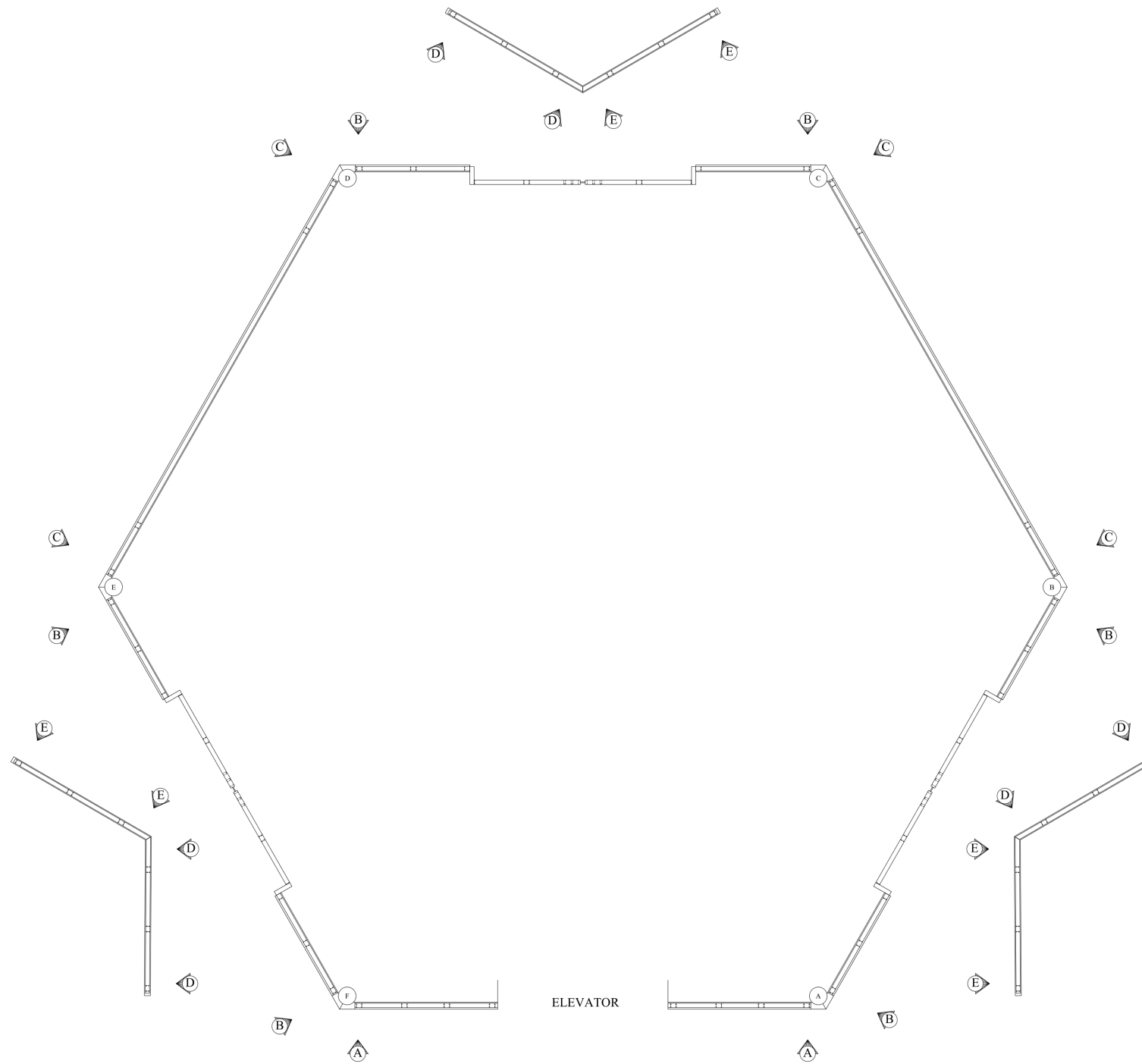

BenFab, Inc.
 13 S. Highland Ave Lansdowne, PA 19050
 Phone: 610-626-9100 Fax: 610-626-9200
www.benfabrailings.com

Sullivan Triad Building PLAN
 200 Renaissance Blvd
 King of Prussia, PA

DRAWN: EY
 DATE: 4/4/14
 REV: 1

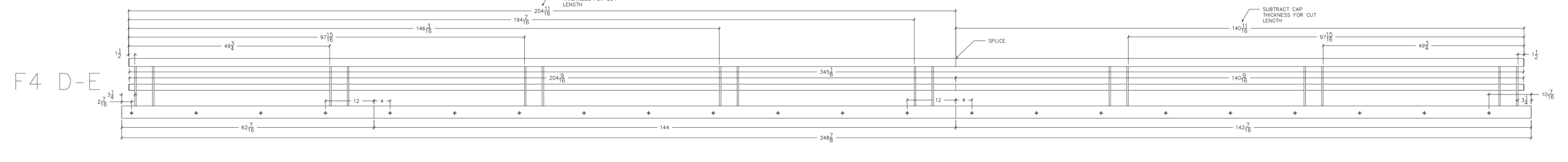
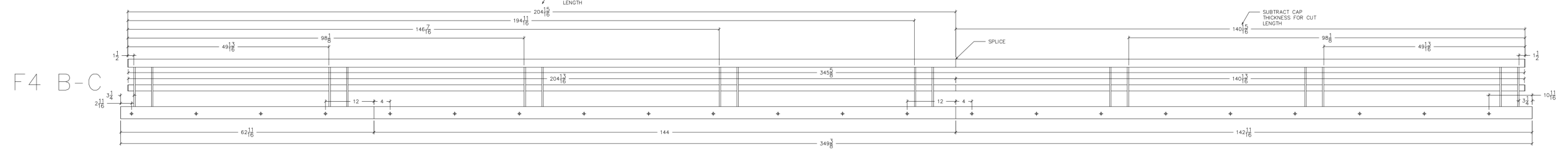
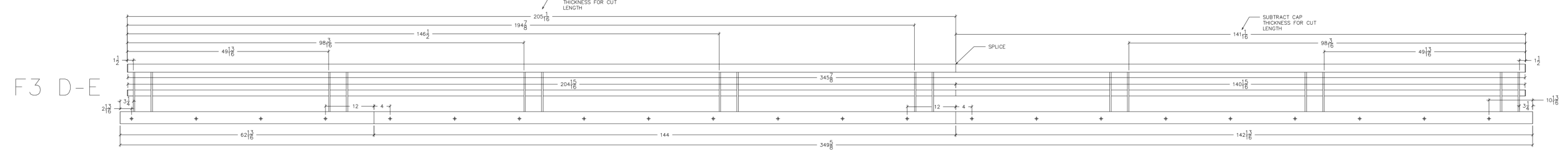
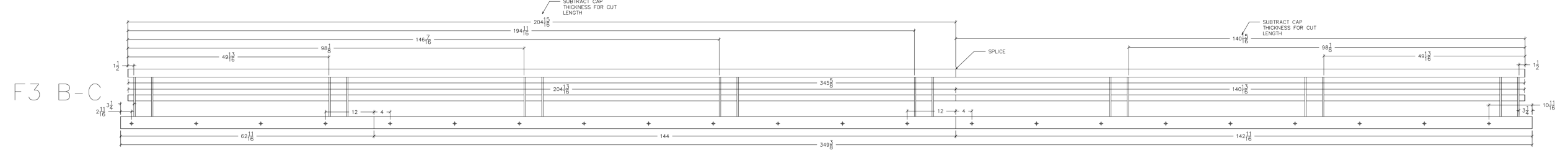
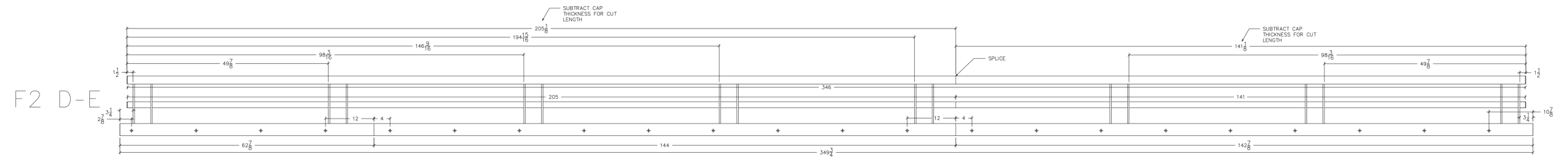
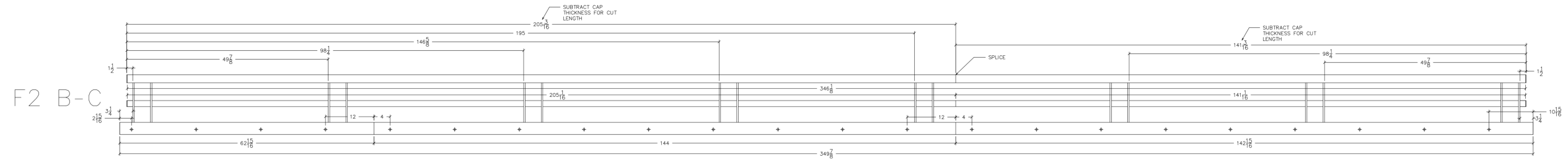

ALL FLOORS
LONG RUN

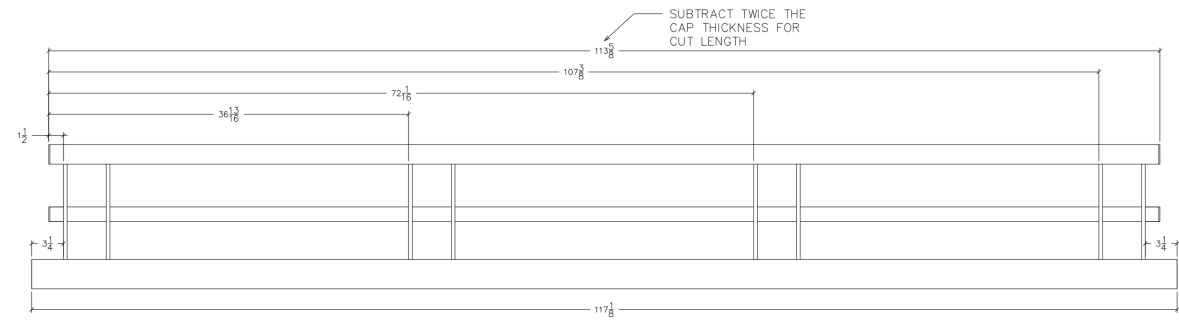

F2 F-ELEV
IS IDENTICAL TO
F3 ELEV-A

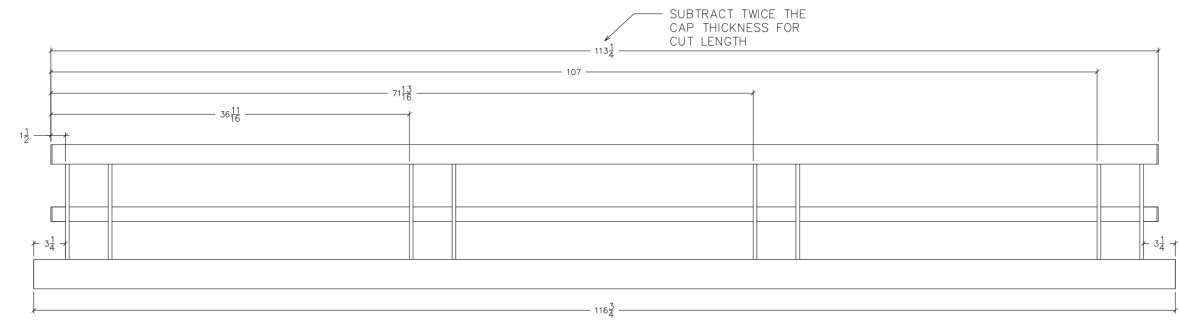

F2 ELEV-A
IS IDENTICAL TO
F3 F-ELEV

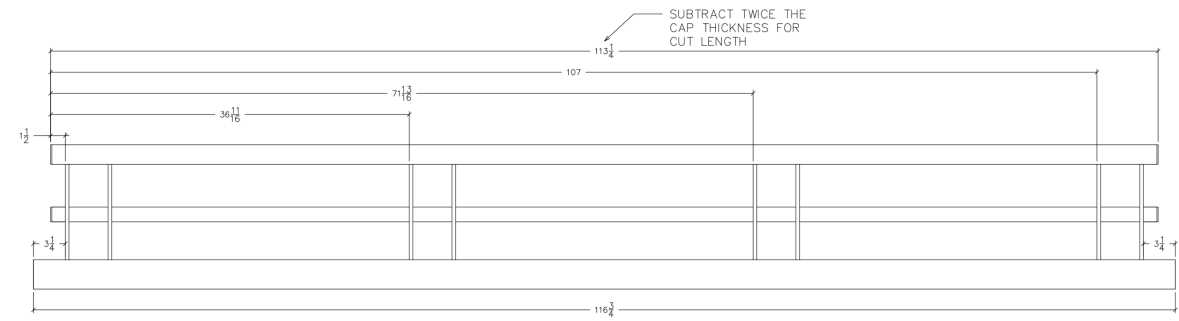

F3 F-ELEV

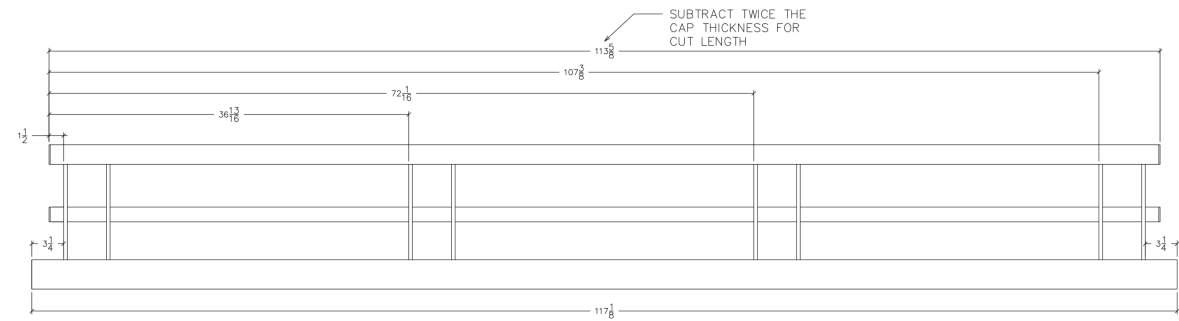

F3 ELEV-A

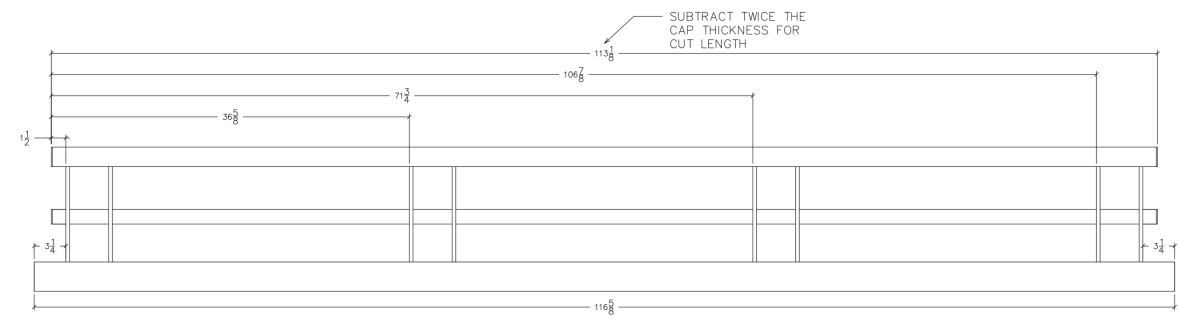

F4 F-ELEV

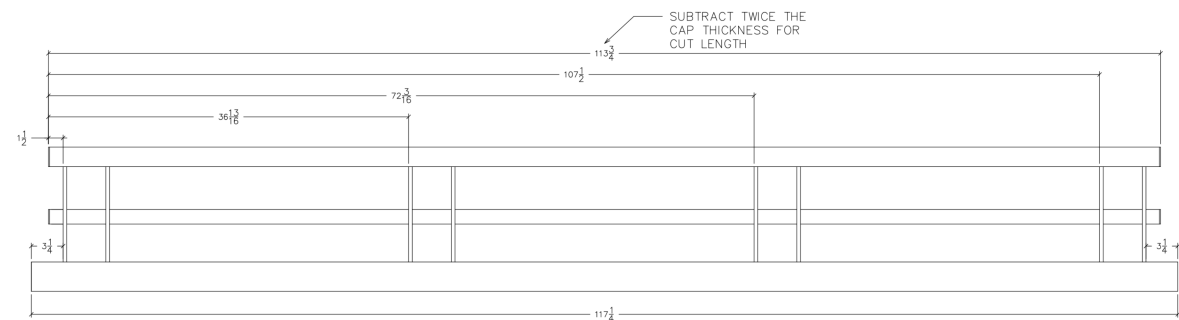

F4 ELEV-A

**ALL FLOORS
ELEVATOR SIDE**

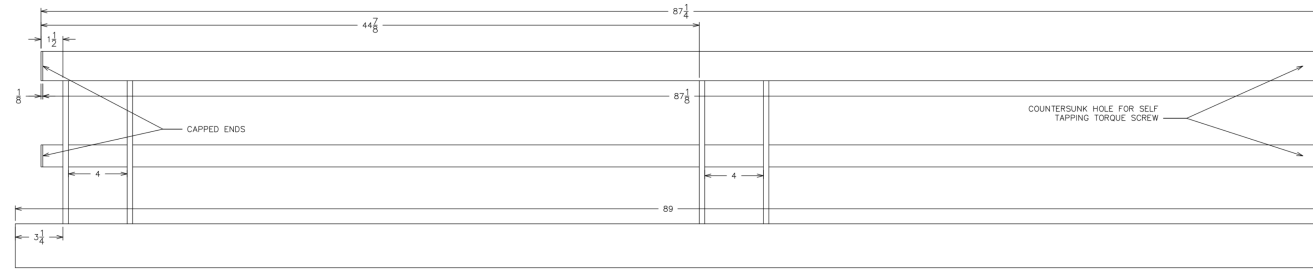

F4 A-B
LEFT

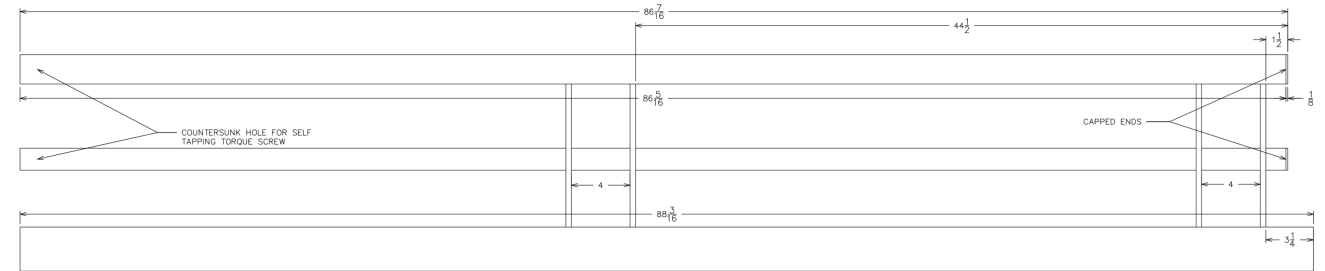

F4 A-B
RIGHT

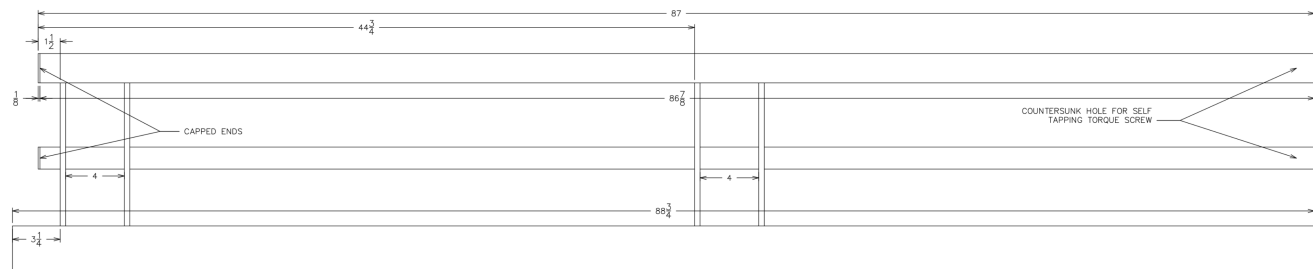

F4 C-D
LEFT

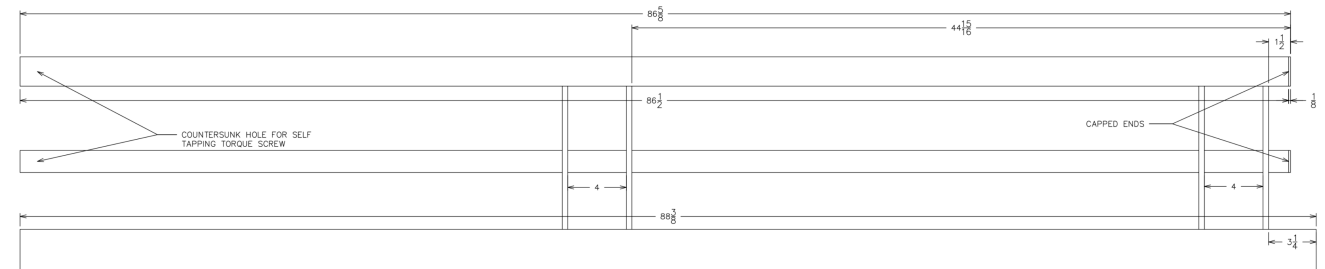

F4 C-D
RIGHT

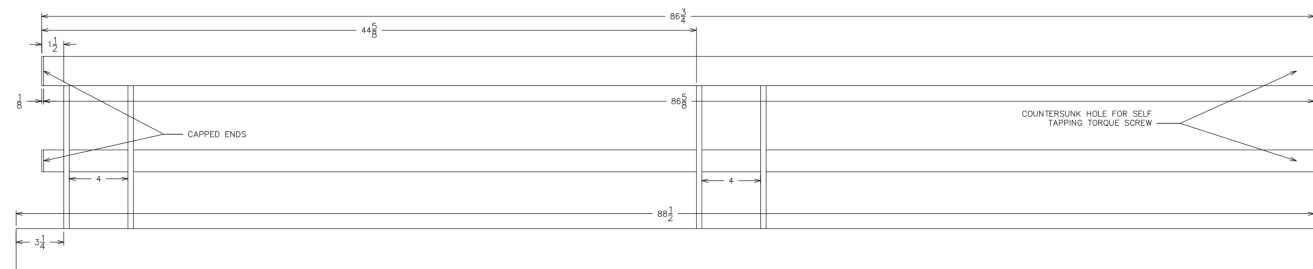

F4 E-F
LEFT

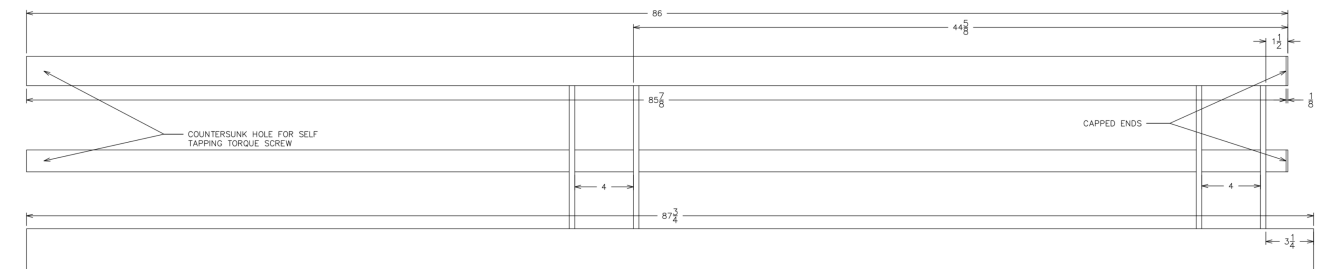

F4 E-F
RIGHT

**FLOOR 4
SPLICES TO OPENINGS**

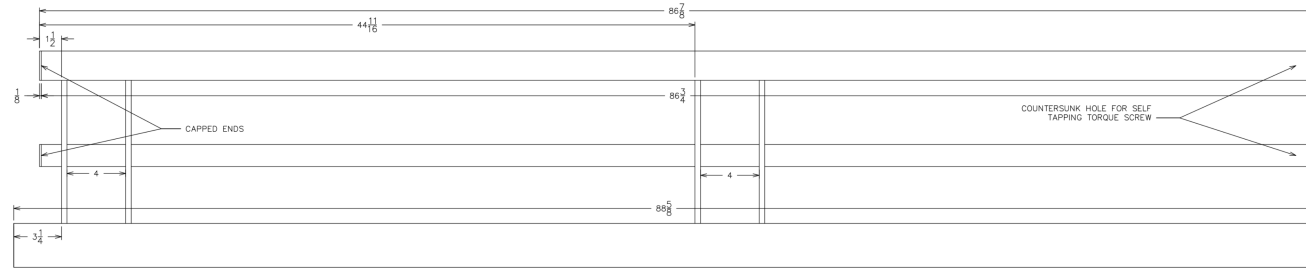

F3 A-B
LEFT

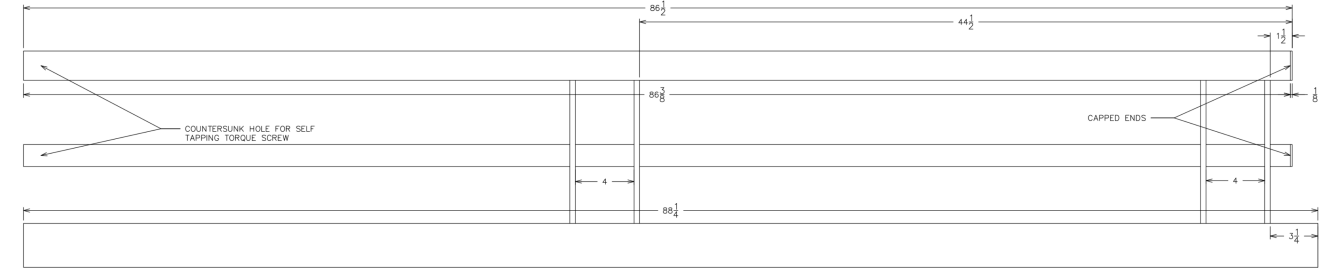

F3 A-B
RIGHT

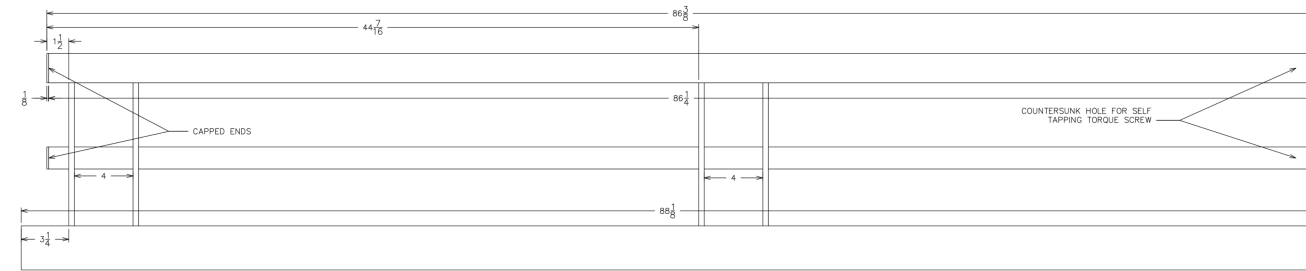

F3 C-D
LEFT

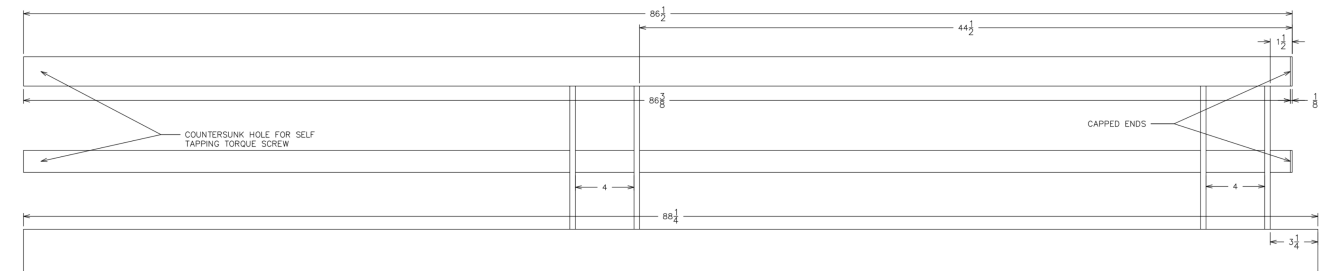

F3 C-D
RIGHT

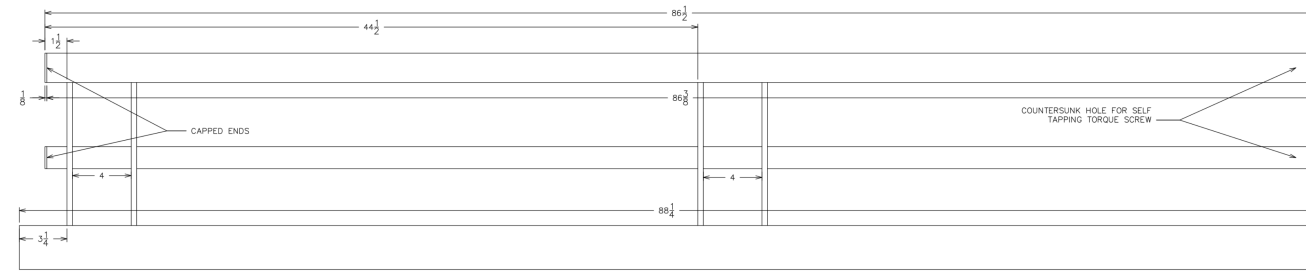

F3 E-F
LEFT

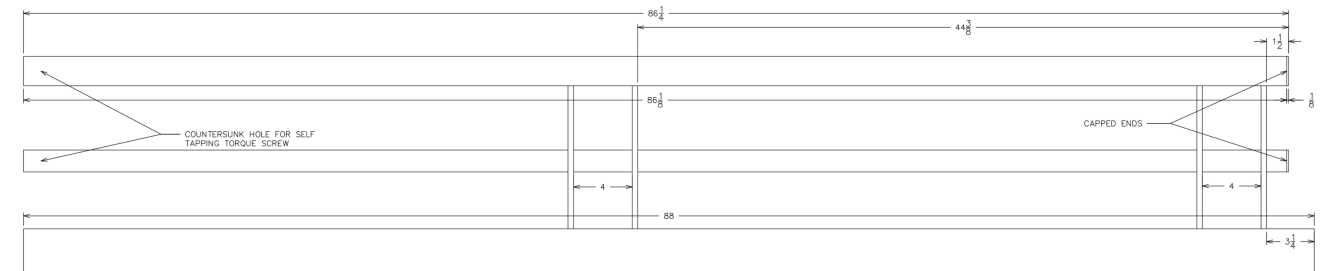

F3 E-F
RIGHT

**FLOOR 3
SPLICES TO OPENINGS**

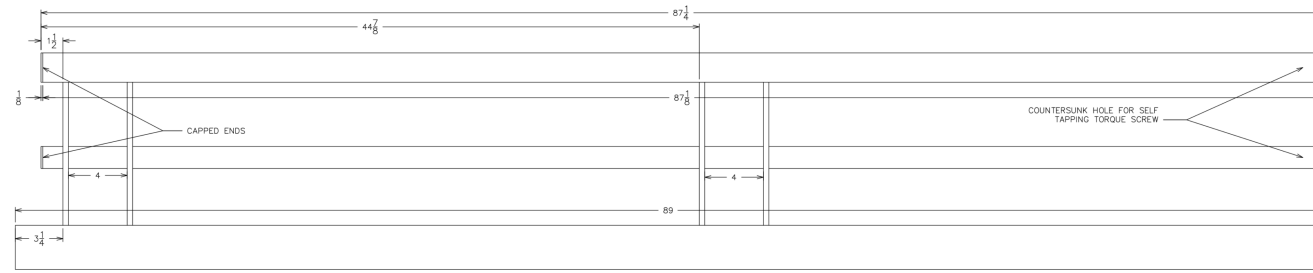

F2 A-B
LEFT

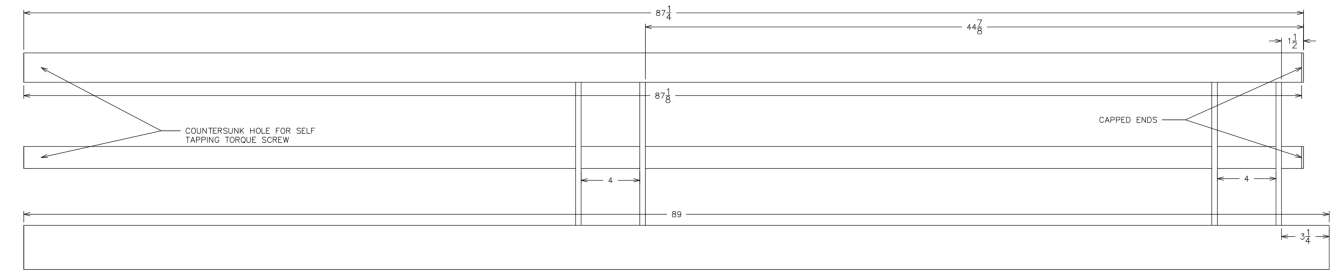

F2 A-B
RIGHT

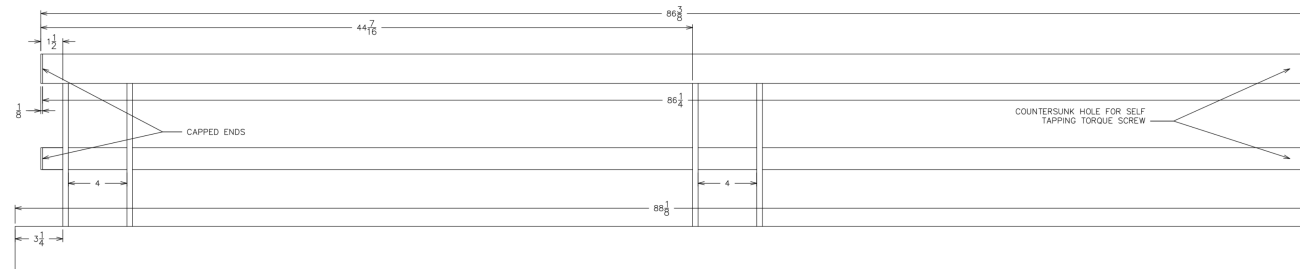

F2 C-D
LEFT

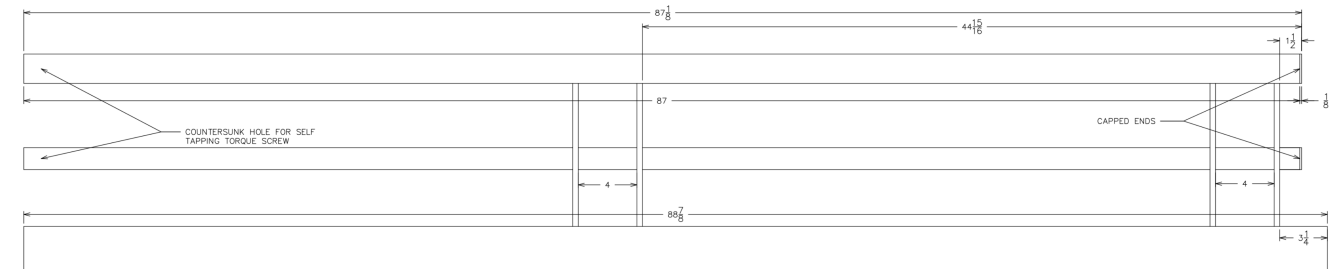

F2 C-D
RIGHT

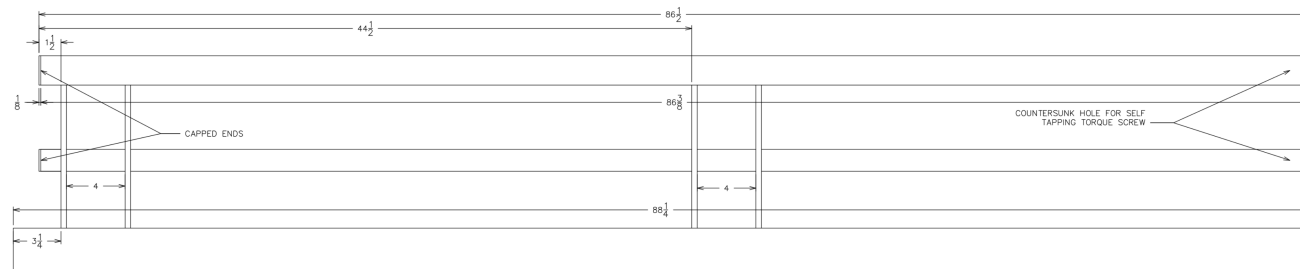

F2 E-F
LEFT

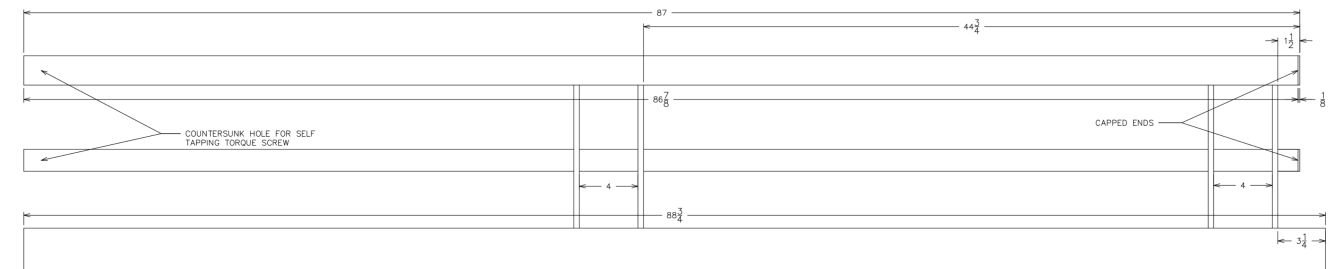

F2 E-F
RIGHT

**FLOOR 2
SPLICES TO OPENINGS**

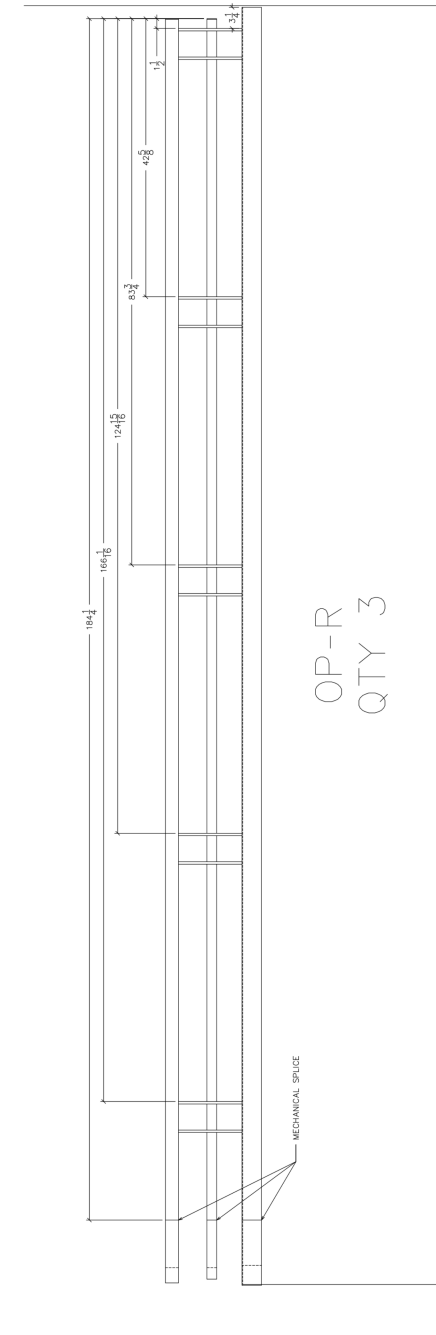
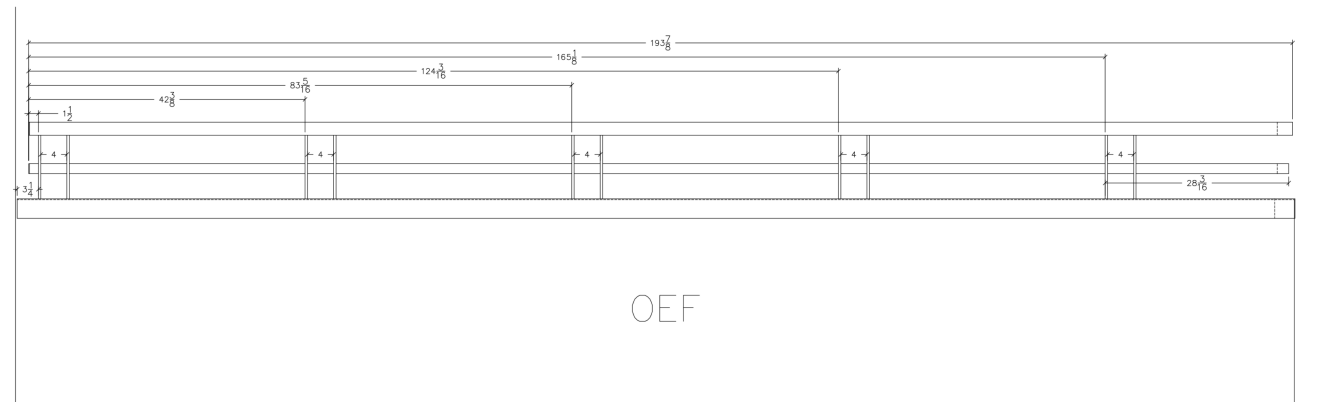
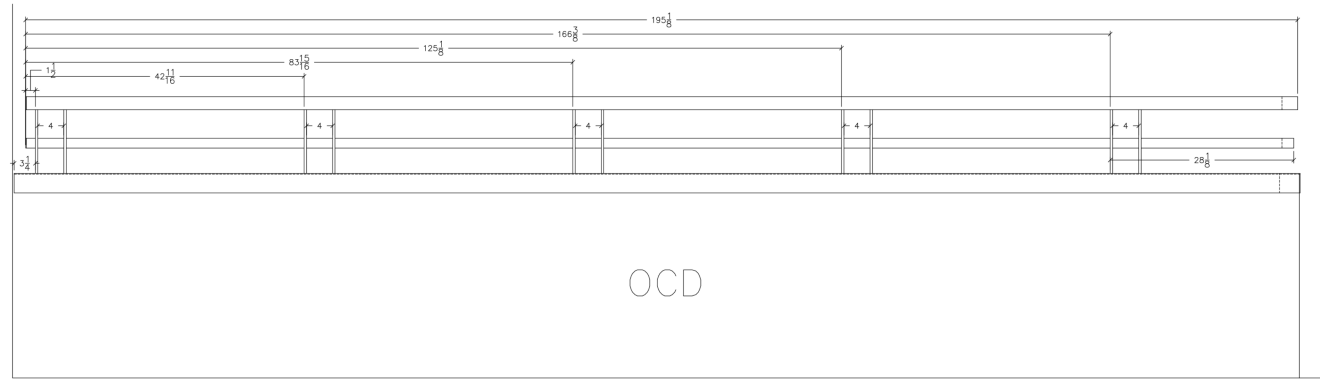
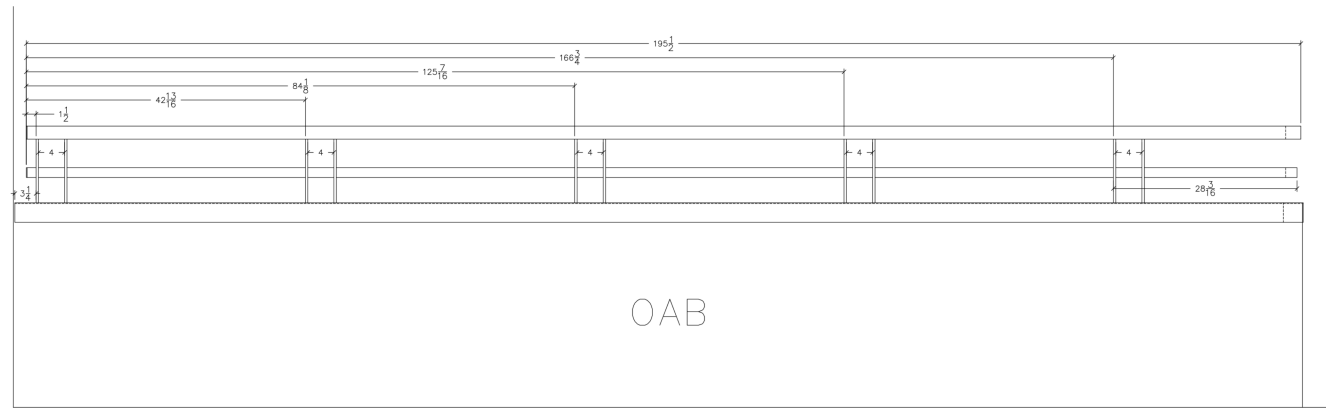

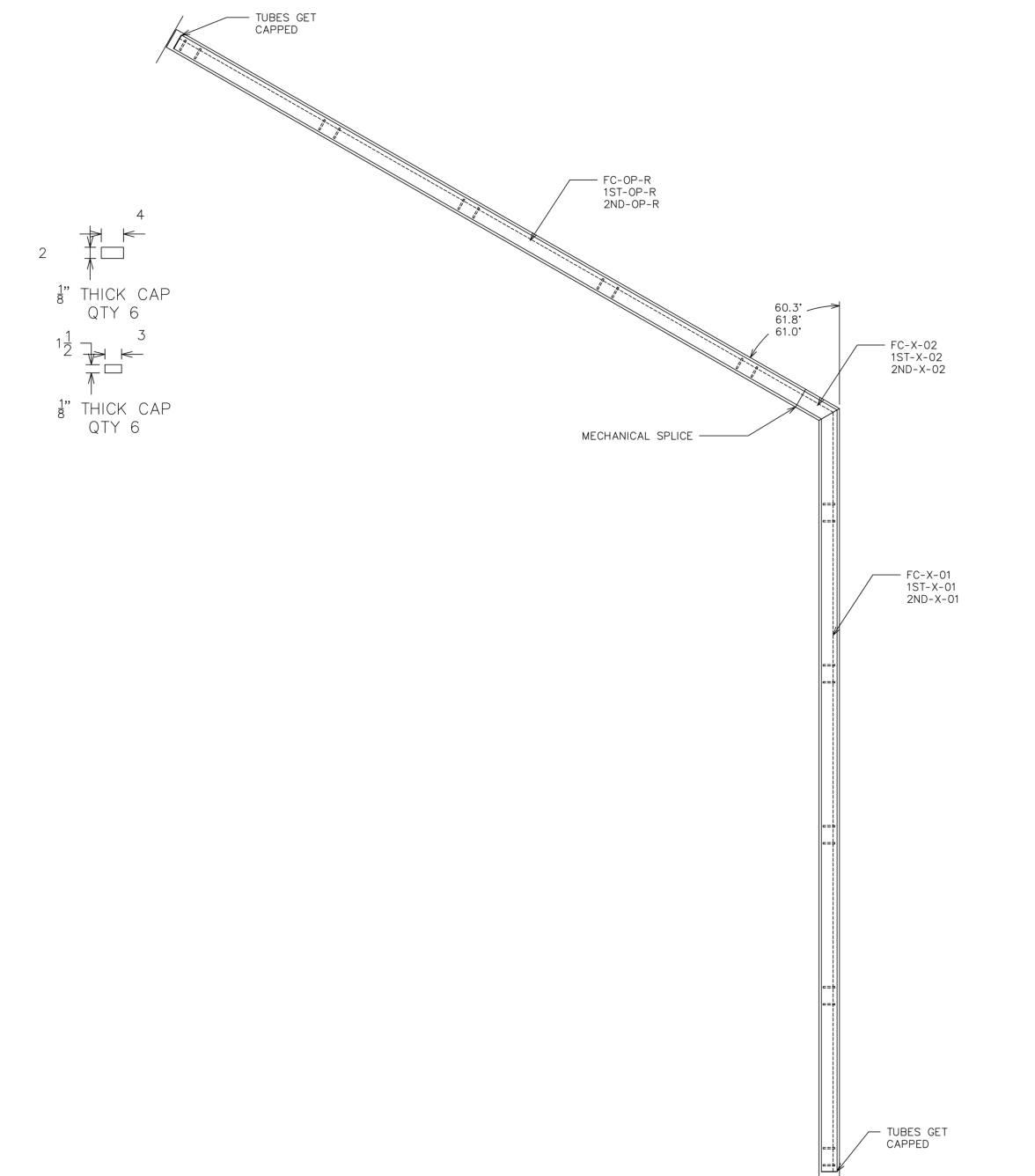
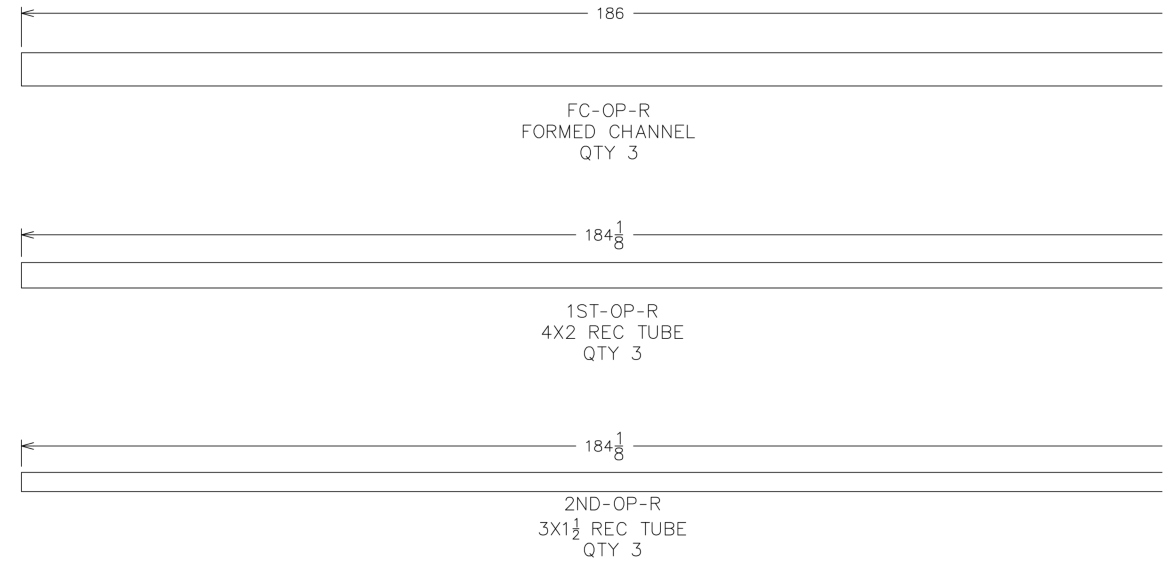
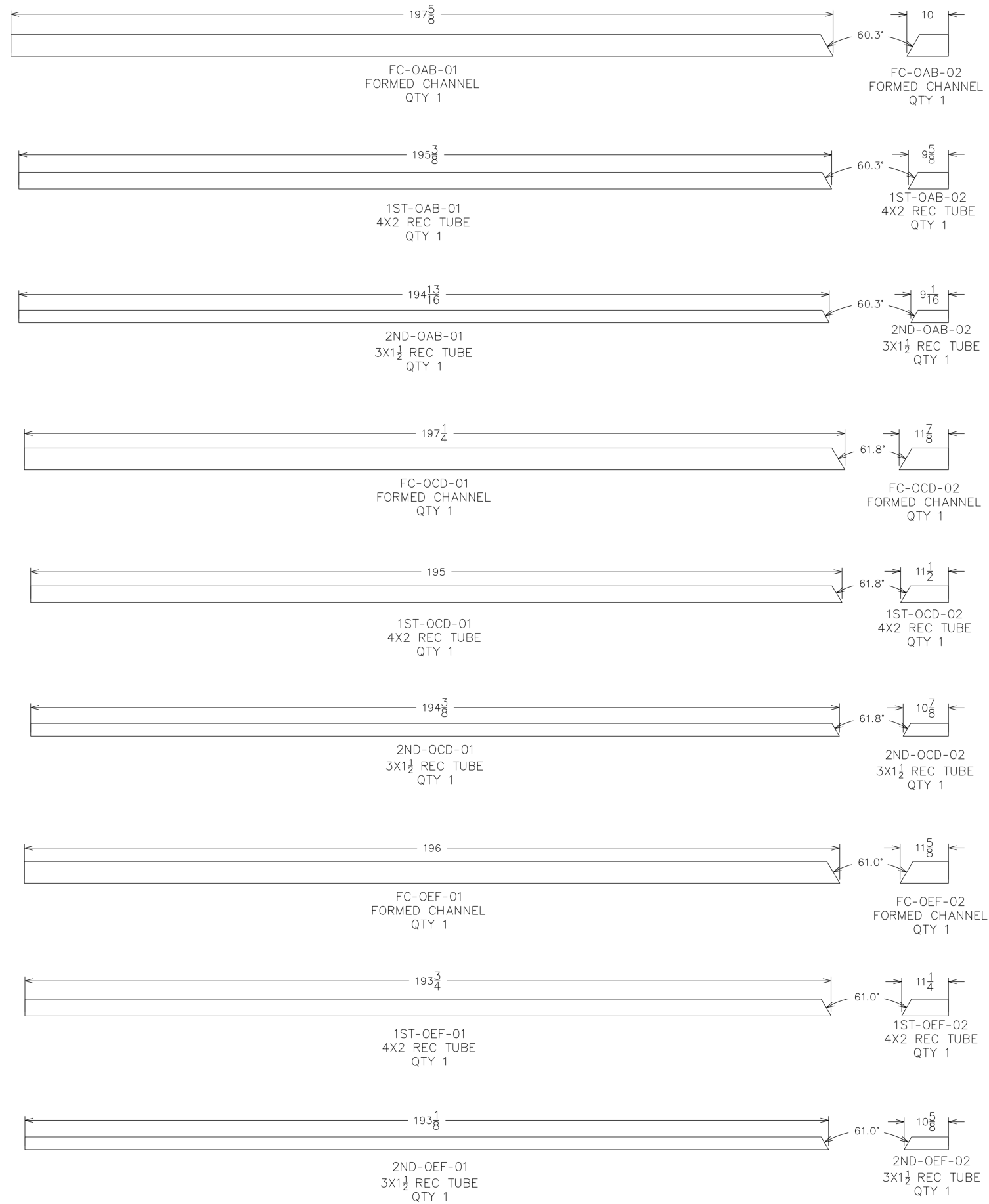

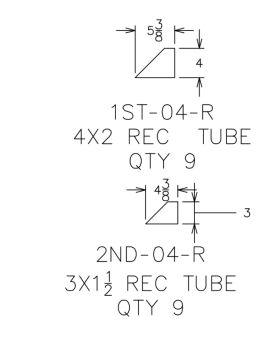
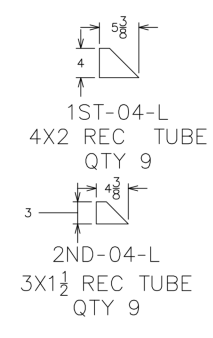
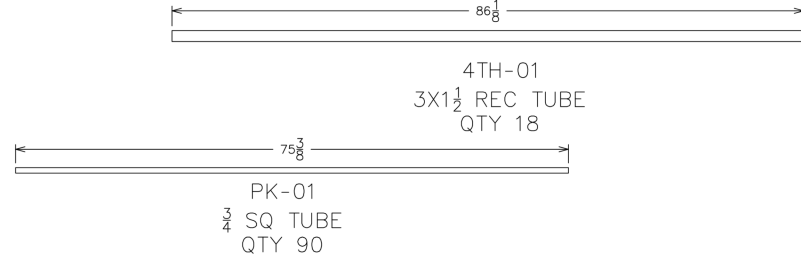
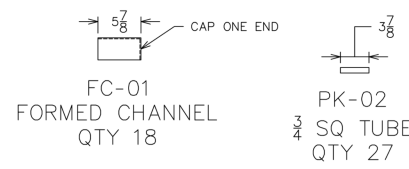
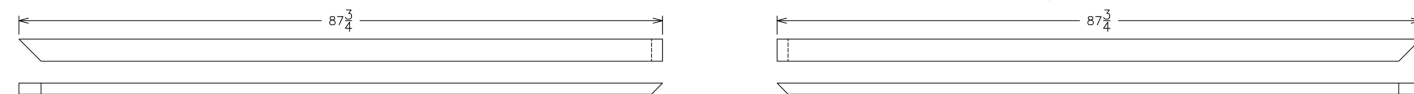
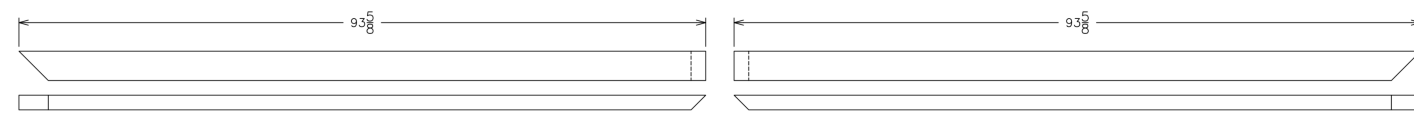
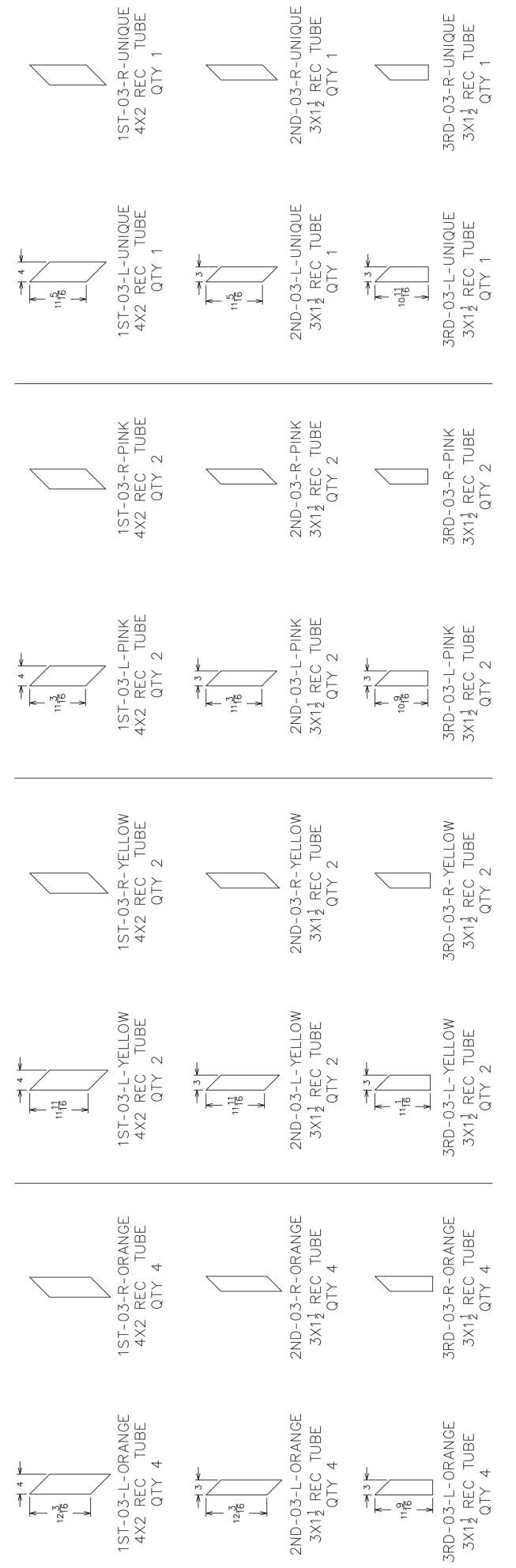
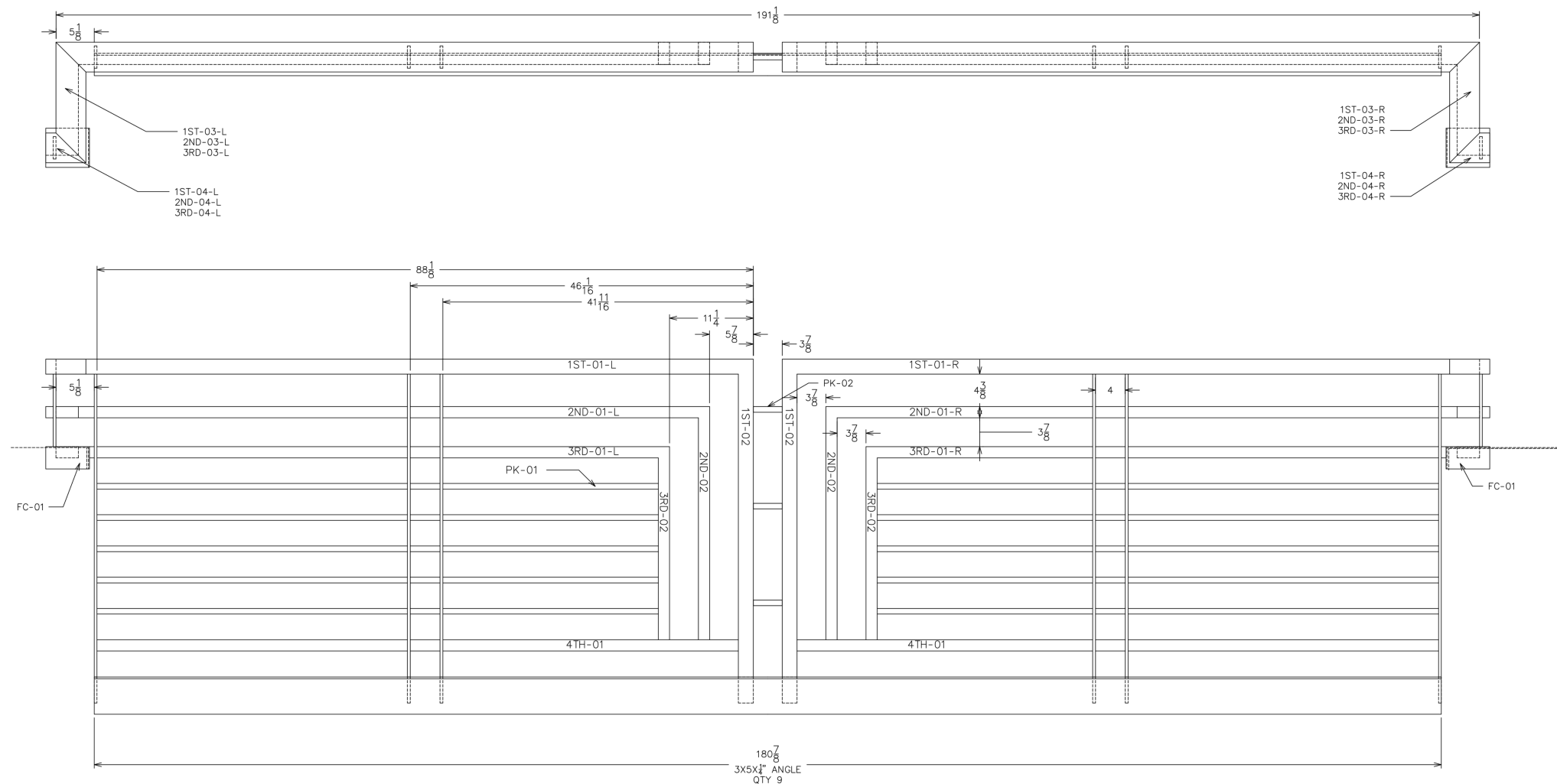

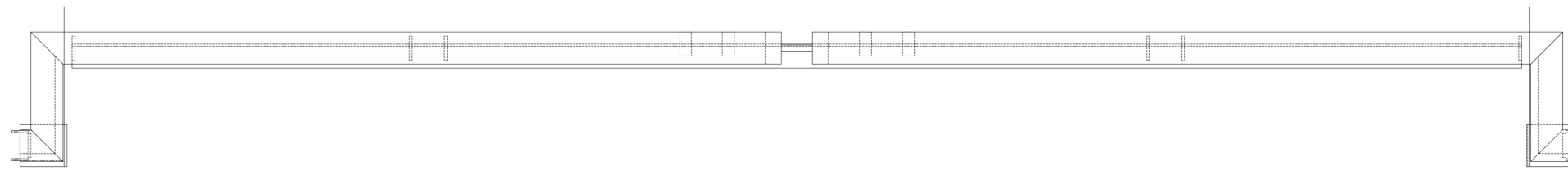

PLAN
SCALE 1 1/2"=1'

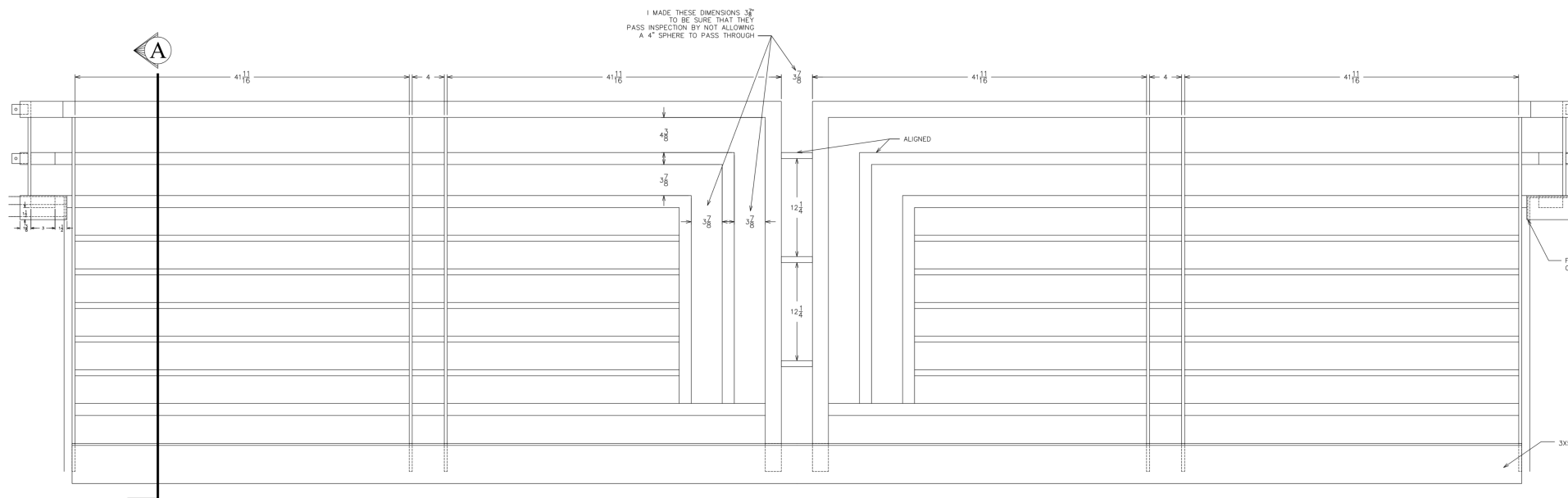

ELEVATION
SCALE 1 1/2"=1'

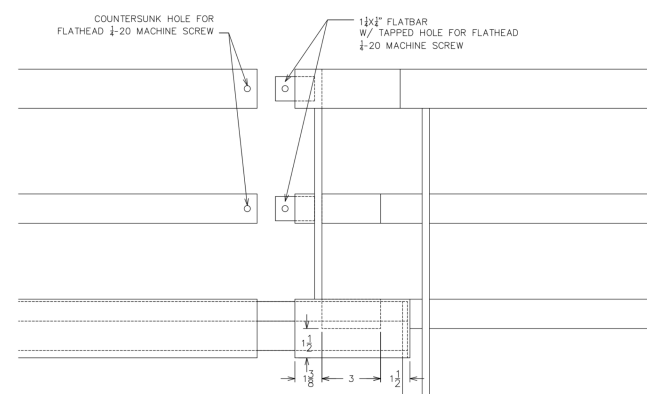

MECHANICAL SPLICE DETAIL
SCALE 3"=1'

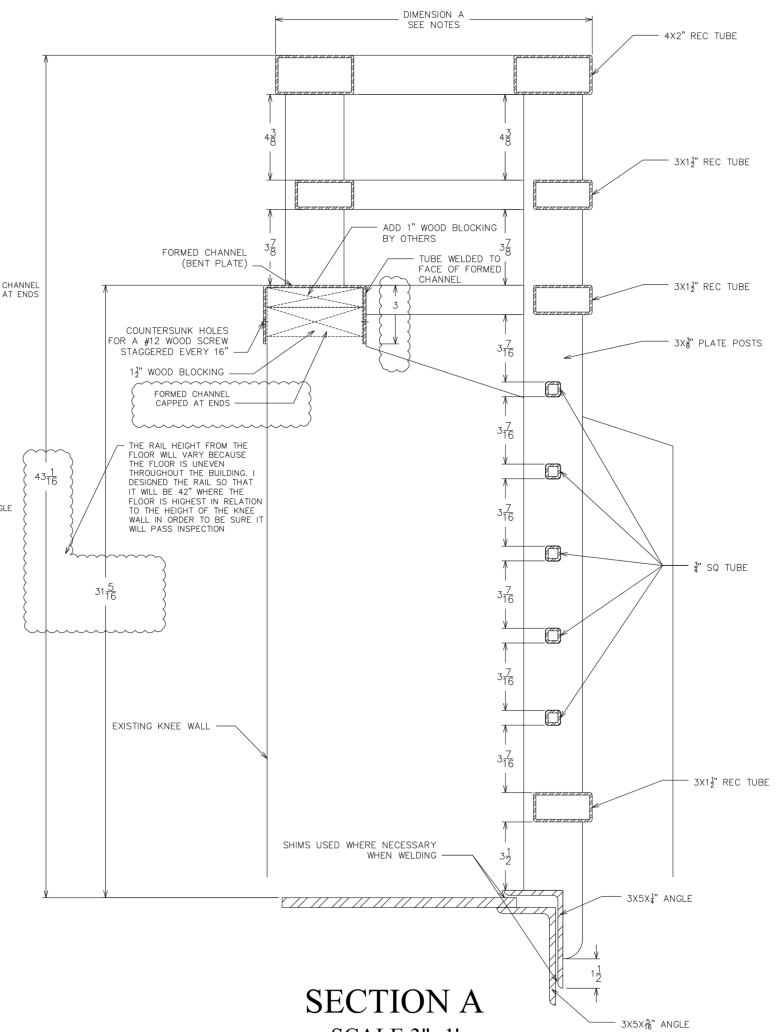

SECTION A
SCALE 3"=1'

NOTES:

In order to account for the variations in height of the knee wall and distance from the knee wall to the 3" X 5" X 5/16" angle, there will be four versions of this guardrail fabricated. What is shown in the elevation view will remain the same for all guard railings. The length of "DIMENSION A" is what will change between those four versions. Shims will be used where necessary to make up the remaining differences where the rail is welded in place at the bottom.

BenFab, Inc.
13 S. Highland Ave Lansdowne, PA 19050
Phone: 610-626-9100 Fax: 610-626-9200
www.benfabrailings.com

Sullivan Triad Building
200 Renaissance Blvd
King of Prussia, PA

TYPICAL DETAILS

DRAWN: EY
DATE: 4/4/14
REV: 1

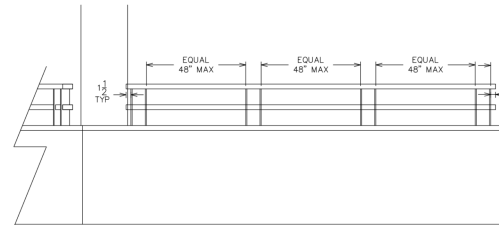
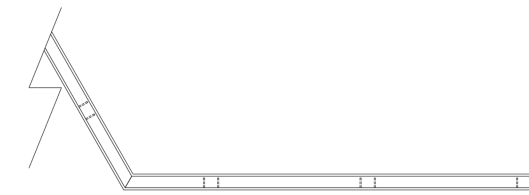
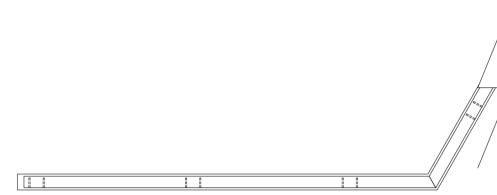
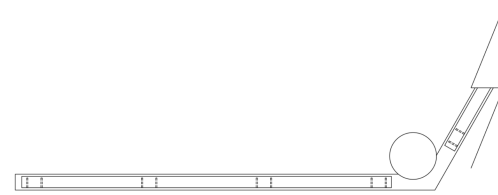
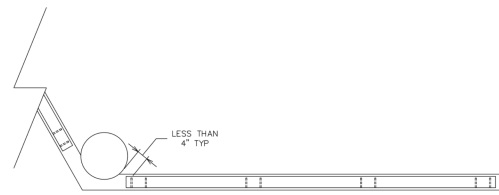

ELEVATOR
SECTION A-A

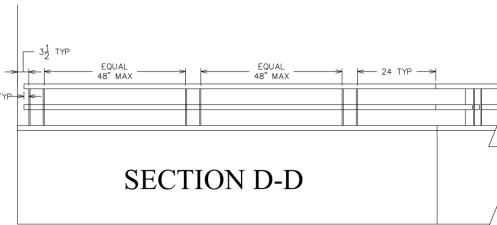
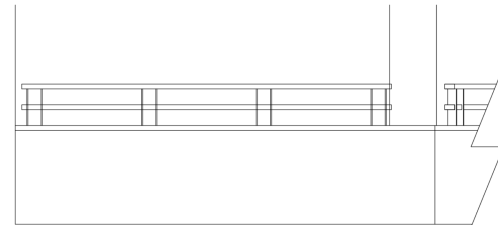

SECTION D-D

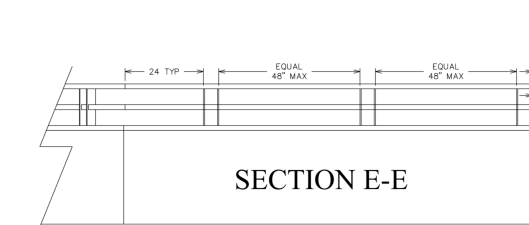

SECTION E-E

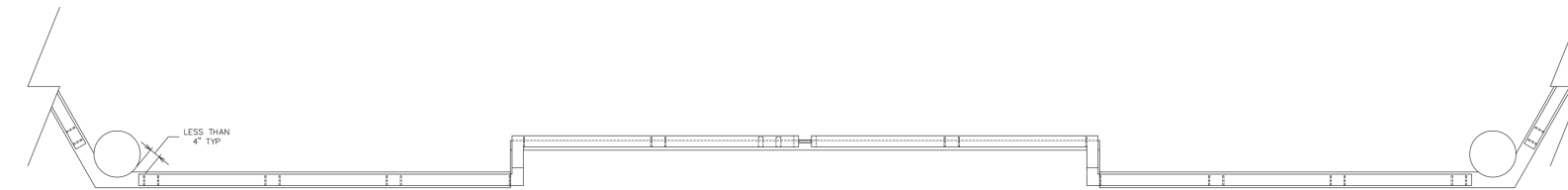

SECTION B-B

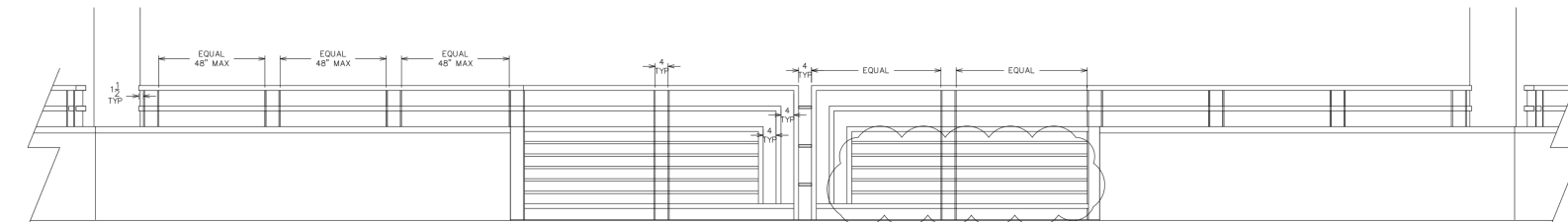

SECTION C-C



After taking our field measurements we have run into these possible issues.

- 1) Due to the current height of the knee wall, to make the top of the rail the required 42" would make the openings between the three rectangular tubes at the top larger than is allowed. I've quoted the applicable building code below.
- 2) A 3-1/2" x 1-1/2" rectangular tube is a very rare and difficult size material to acquire. Only one of the suppliers I've called was able to find any at all, and that was at four times the price of a 3 x 1-1/2" tube and with a two week lead time.
 - a) Possible solution: If we switch the top rail to a 3-1/2" x 3-1/2" sq tube that would solve both the material availability problem and the building code opening limitations.

1013.4 Opening limitations. Required *guards* shall not have openings which allow passage of a sphere 4 inches (102 mm) in diameter from the walking surface to the required *guard* height.

Exceptions:

1. From a height of 36 inches (914 mm) to 42 inches (1067 mm), *guards* shall not have openings which allow passage of a sphere 4 1/4 inches (111 mm) in diameter.

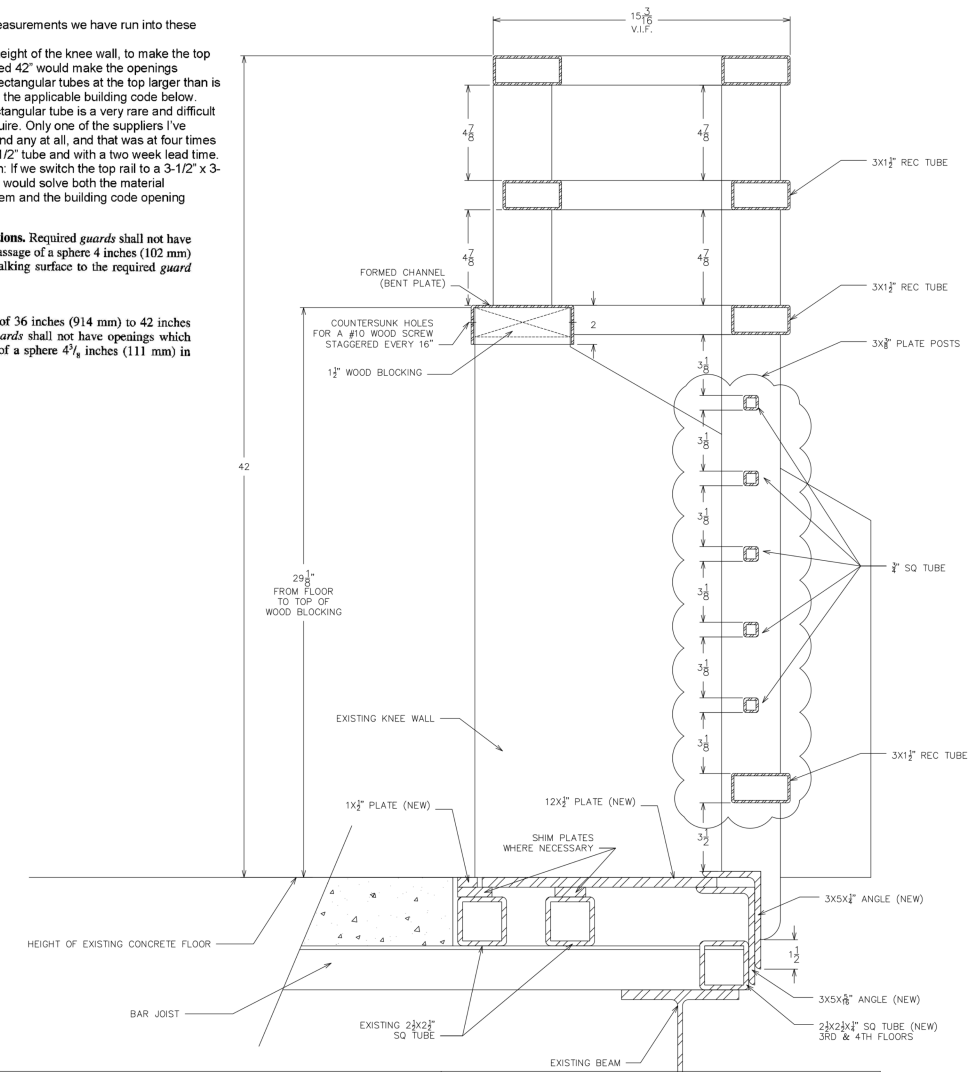

TYPICAL DETAILS

BenFab, Inc.
 13 S. Highland Ave Lansdowne, PA 19050
 Phone: 610-626-9100 Fax: 610-626-9200
www.benfabrailings.com

Sullivan Triad Building
 200 Renaissance Blvd
 King of Prussia, PA

DRAWN: EY
 DATE: 4/4/14
 REV: 1

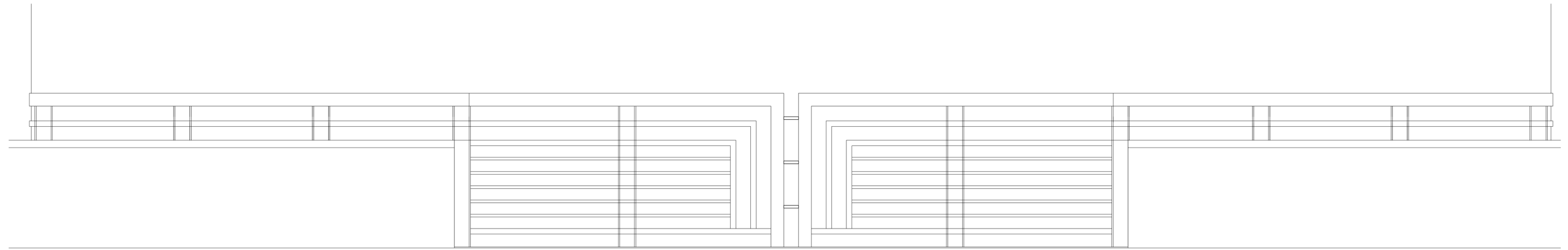

SECTION B-B

OPTION 1:
 $3\frac{1}{2} \times 3\frac{1}{2}$ " SQ TUBE TOP RAIL

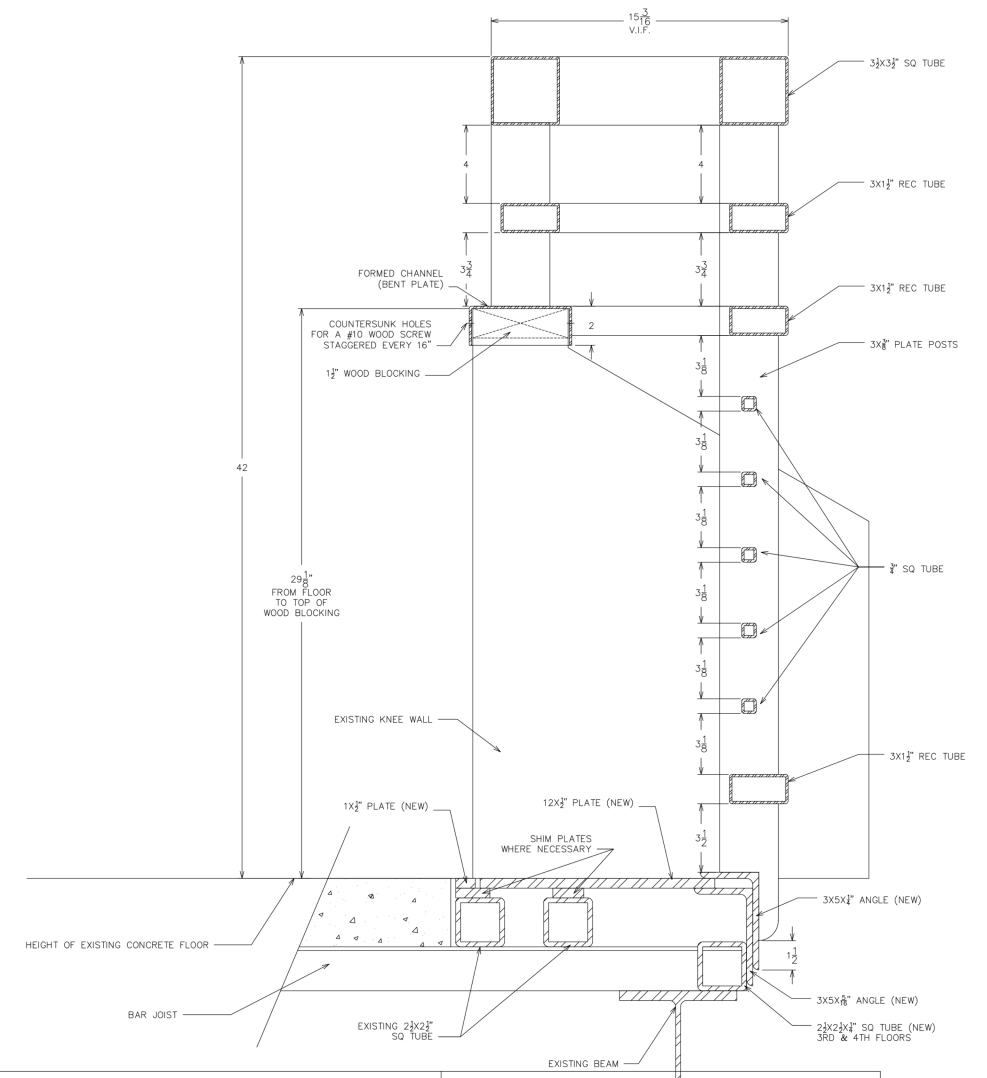

BenFab, Inc.
 13 S. Highland Ave Lansdowne, PA 19050
 Phone: 610-626-9100 Fax: 610-626-9200
www.benfabrailings.com

Sullivan Triad Building
 200 Renaissance Blvd
 King of Prussia, PA

TYPICAL DETAILS

DRAWN: EY
 DATE: 4/4/14
 REV: 1

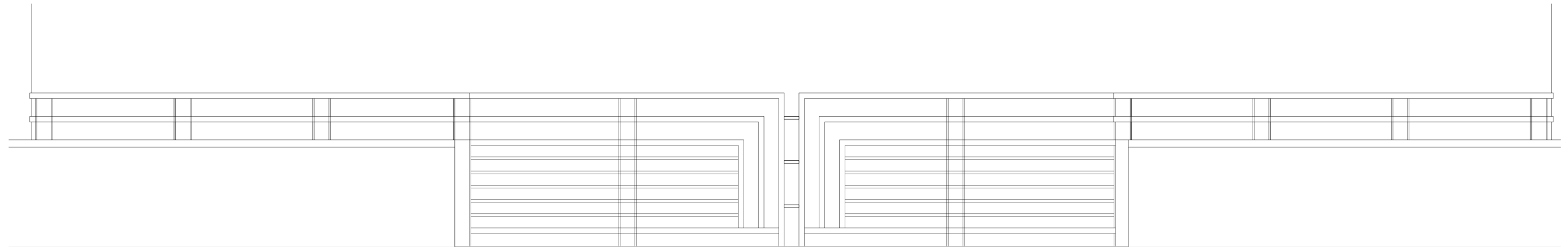

SECTION B-B

OPTION 2:
3 X 1 1/2" REC TUBE TOP RAIL

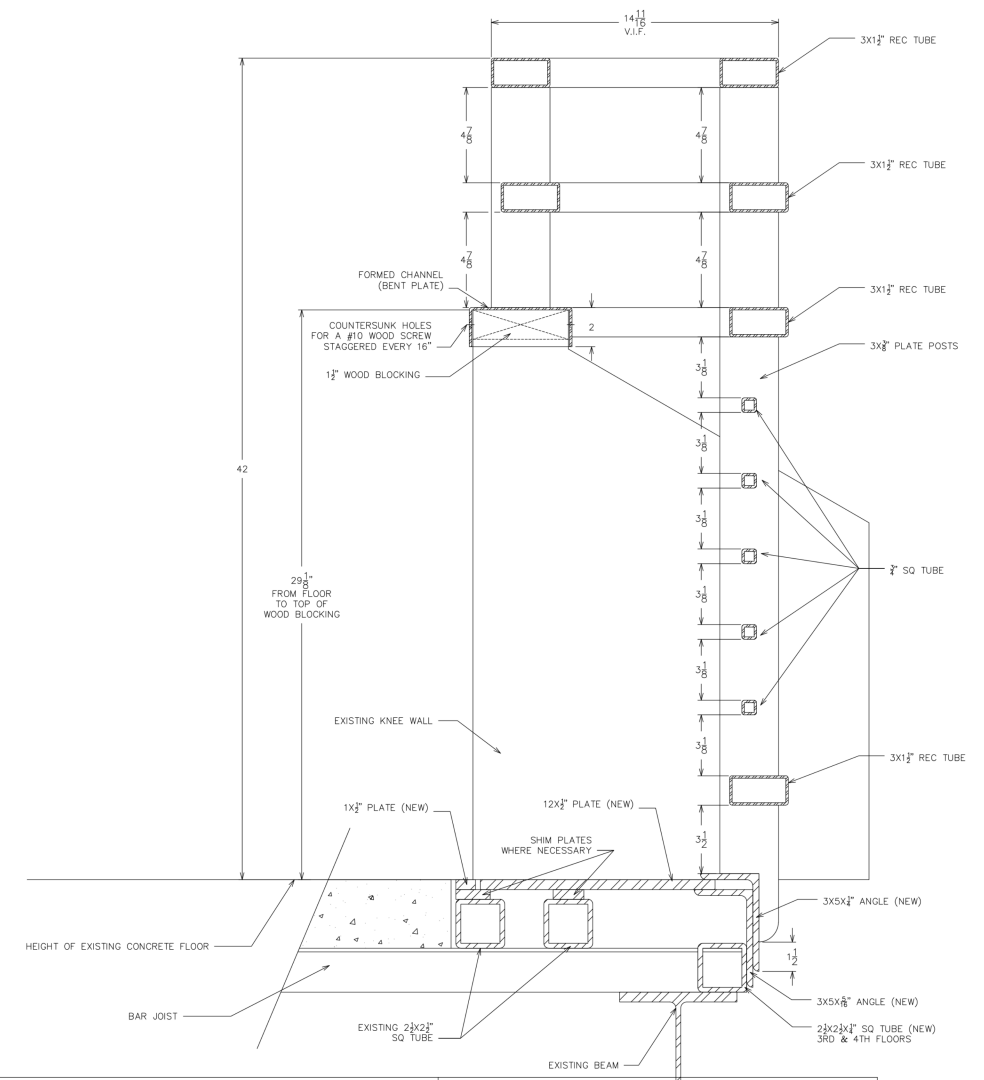

BenFab, Inc.
13 S. Highland Ave Lansdowne, PA 19050
Phone: 610-626-9100 Fax: 610-626-9200
www.benfabrailings.com

Sullivan Triad Building
200 Renaissance Blvd
King of Prussia, PA

TYPICAL DETAILS

DRAWN: EY

DATE: 4/4/14

REV: 1

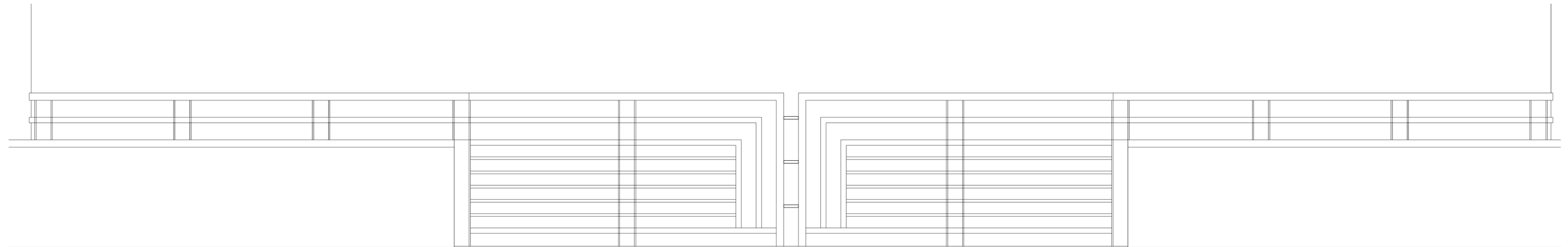

SECTION B-B

OPTION 3:
4 X 2" REC TUBE TOP RAIL

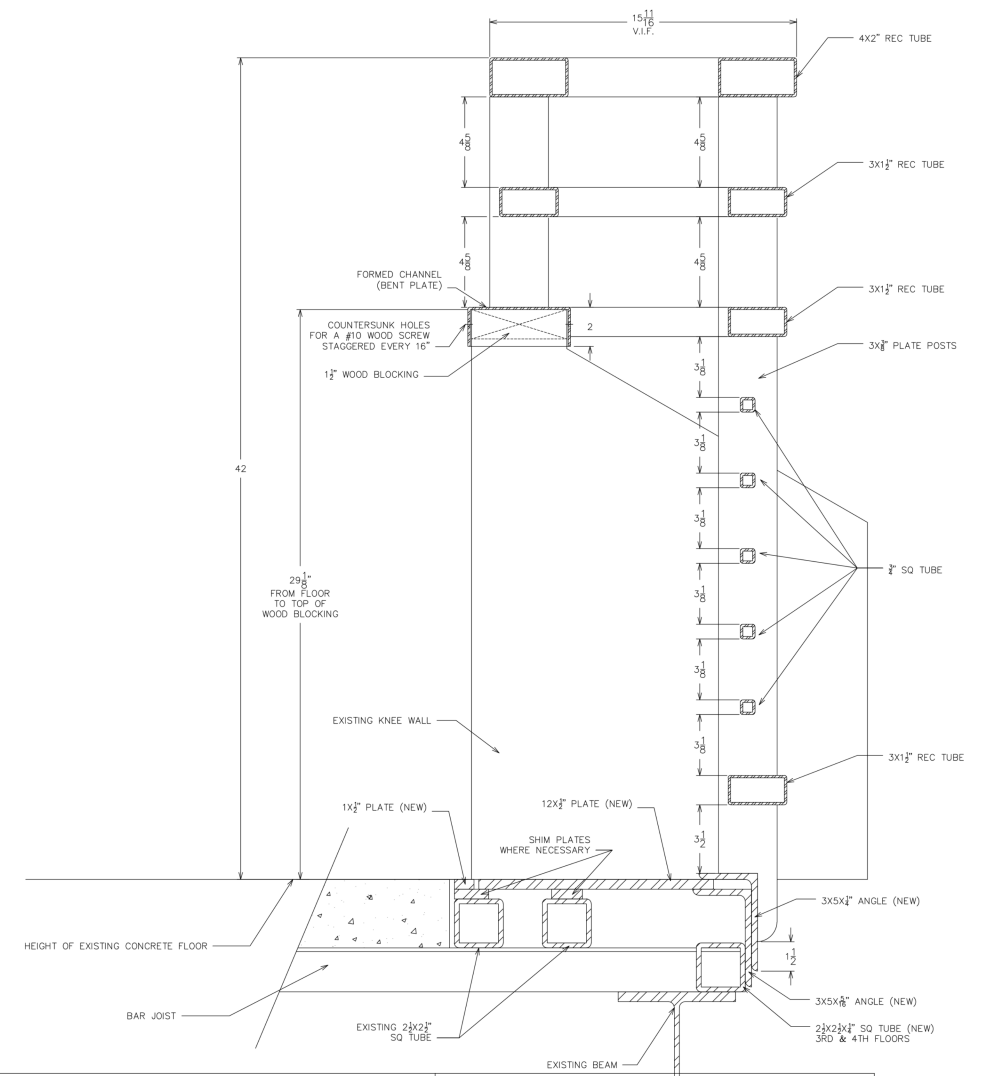

BenFab, Inc.
13 S. Highland Ave Lansdowne, PA 19050
Phone: 610-626-9100 Fax: 610-626-9200
www.benfabrailings.com

Sullivan Triad Building
200 Renaissance Blvd
King of Prussia, PA

TYPICAL DETAILS

DRAWN: EY

DATE: 4/4/14

REV: 1

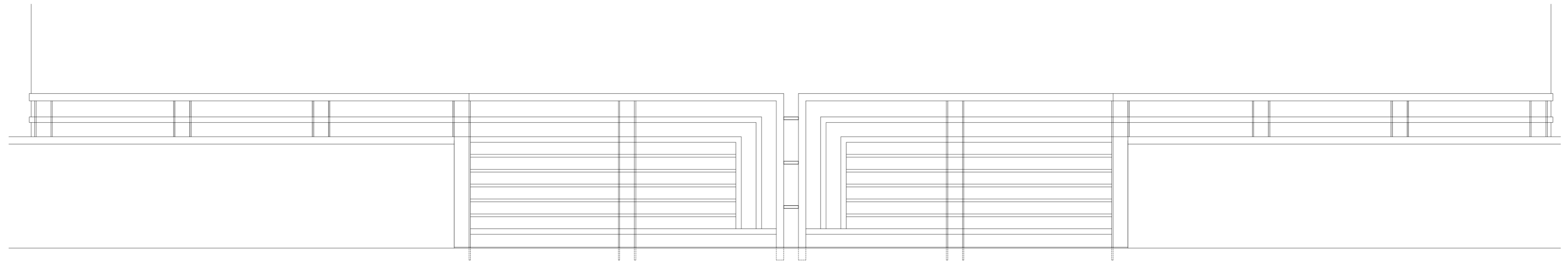

SECTION B-B

OPTION 4:
 4 X 2" REC TUBE TOP RAIL (CENTERED)
 ADD 1" WOOD BLOCKING TO RAISE
 OVERALL KNEE WALL HEIGHT

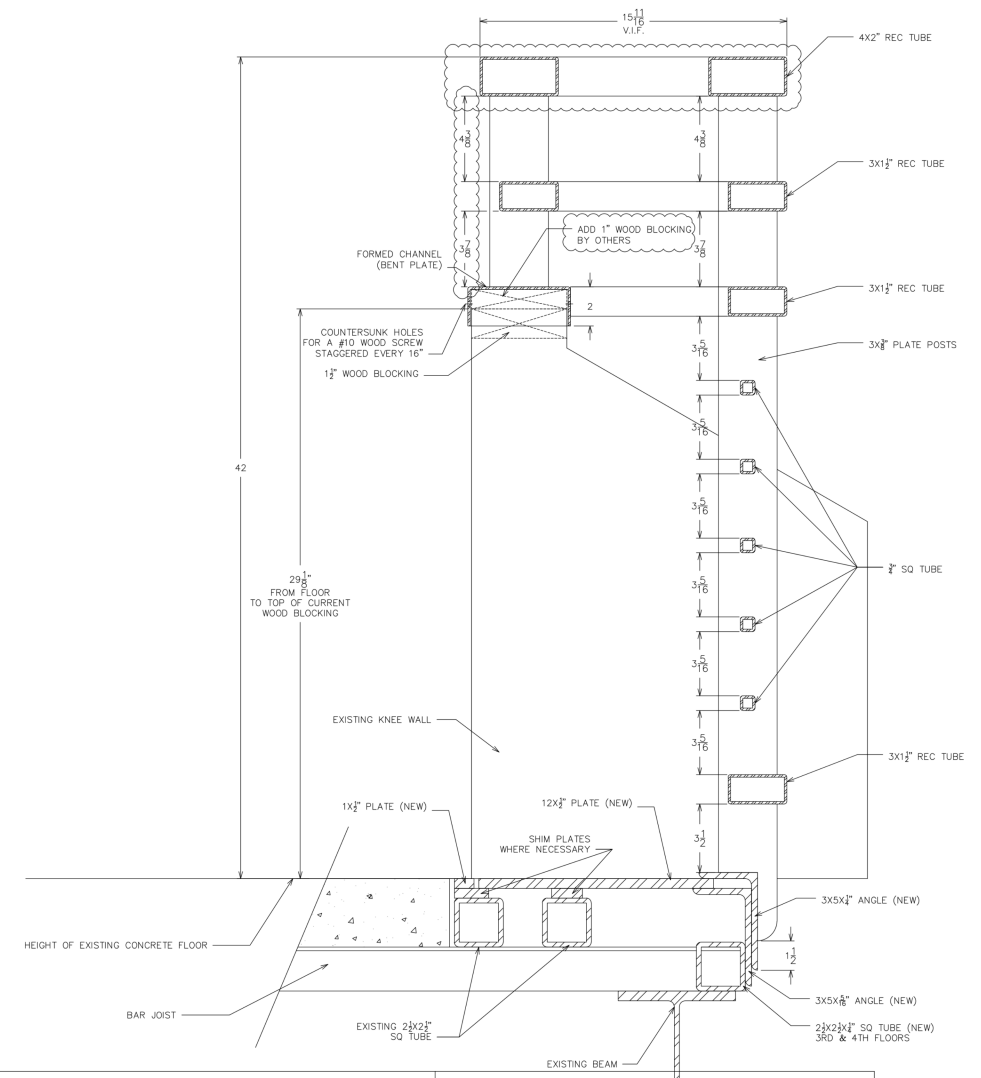

BenFab, Inc.
 13 S. Highland Ave Lansdowne, PA 19050
 Phone: 610-626-9100 Fax: 610-626-9200
www.benfabrailings.com

Sullivan Triad Building
 200 Renaissance Blvd
 King of Prussia, PA

TYPICAL DETAILS

DRAWN: EY

DATE: 4/4/14

REV: 1

After taking our field measurements we have run into these possible issues:

- 1) Due to the current height of the knee wall, to make the top of the rail the required 42" would make the openings between the three rectangular tubes at the top larger than is allowed. I've checked the applicable building code below and a 3'-0" x 3'-0" rectangular tube is a very rare and difficult size material to acquire. Only one of the suppliers I've called was able to find any at all, and that was at four times the price of the other suppliers.
- 2) A 3'-0" x 3'-0" rectangular tube is a very rare and difficult size material to acquire. Only one of the suppliers I've called was able to find any at all, and that was at four times the price of the other suppliers.

Proposed Solution: Proposed panels shall not have openings which allow passage of a sphere 4 inches (102 mm) in diameter from the walking surface to the required guard height.

Exceptions:

1. From a height of 36 inches (914 mm) to 42 inches (1067 mm), panels shall not have openings which allow passage of a sphere 4 inches (102 mm) in diameter.

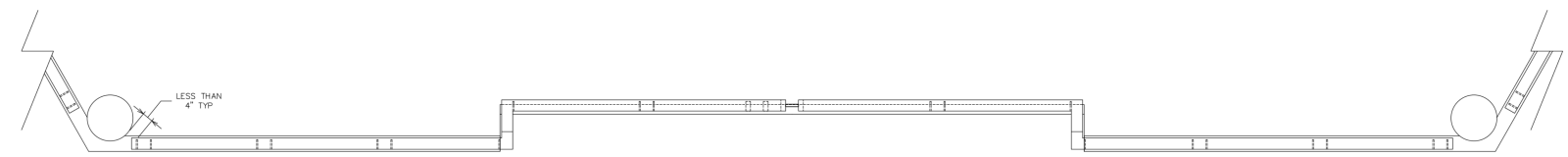
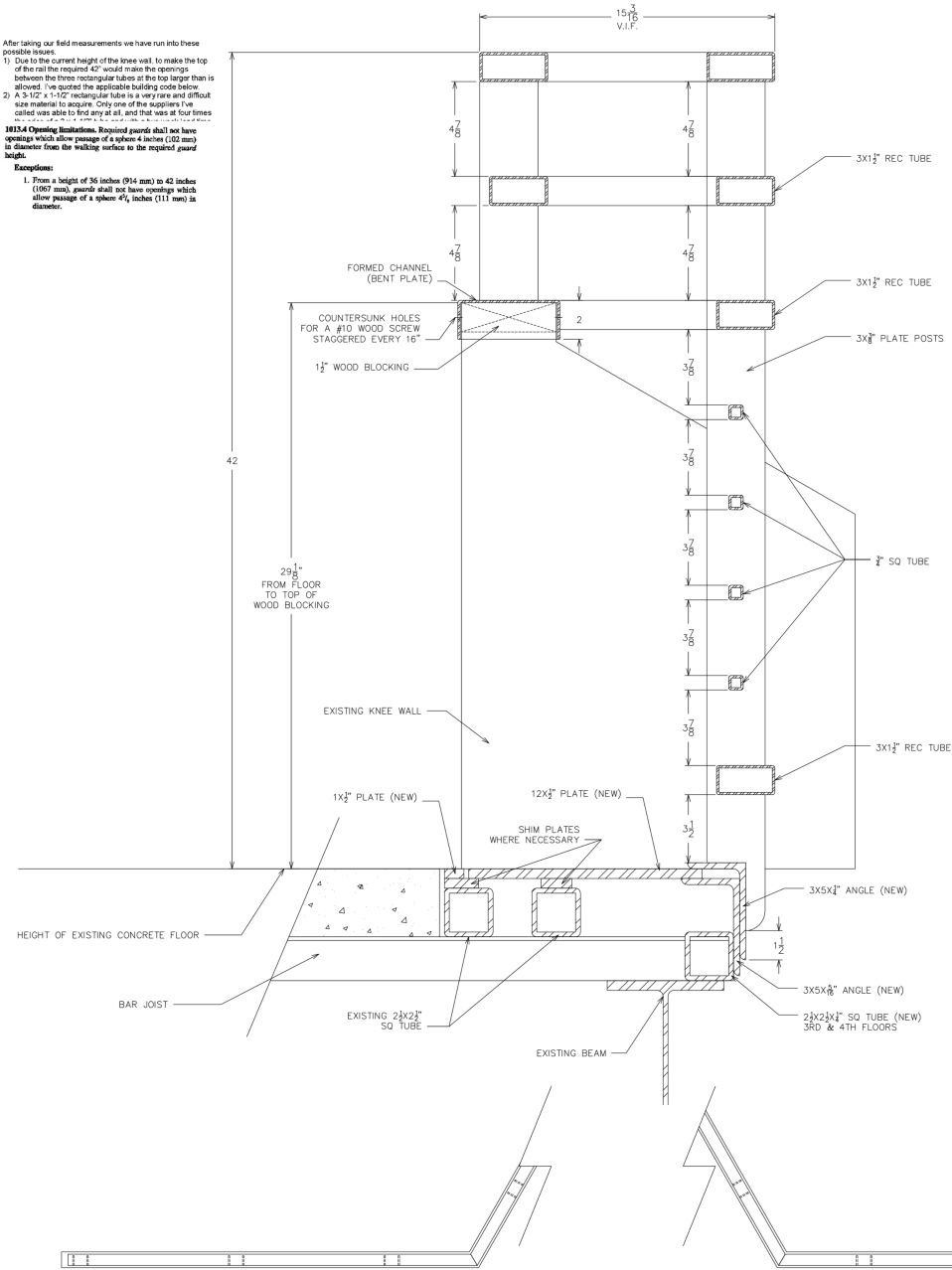

SECTION B-B



SECTION C-C



ELEVATOR

SECTION A-A

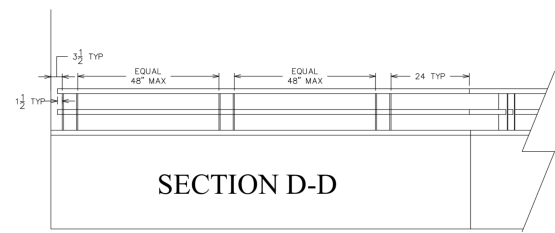

SECTION D-D

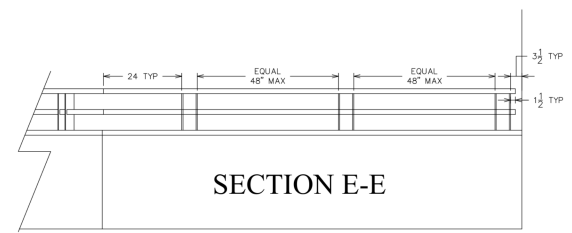

SECTION E-E

BenFab, Inc.
 13 S. Highland Ave Lansdowne, PA 19050
 Phone: 610-626-9100 Fax: 610-626-9200
www.benfabrailings.com

Sullivan Triad Building
 200 Renaissance Blvd
 King of Prussia, PA

DRAWN: EY
 DATE: 4/4/14
 REV: 1

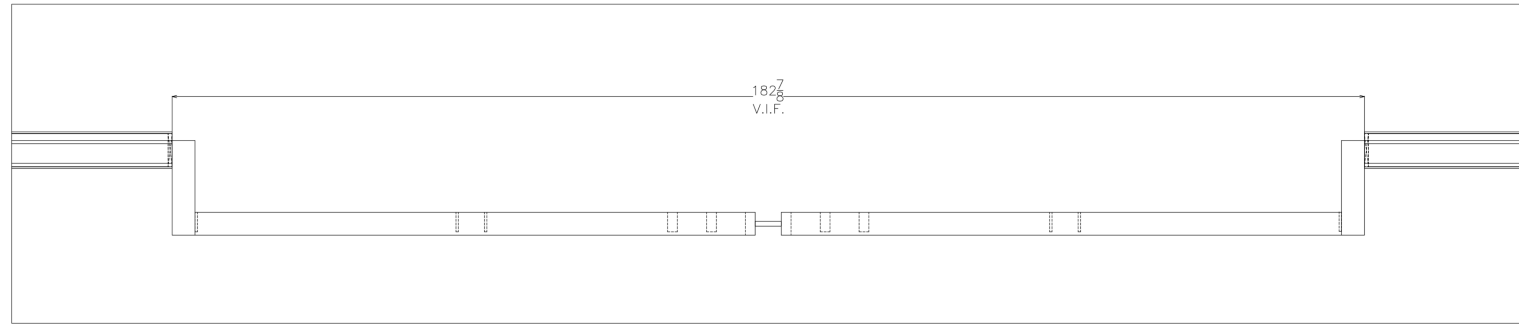
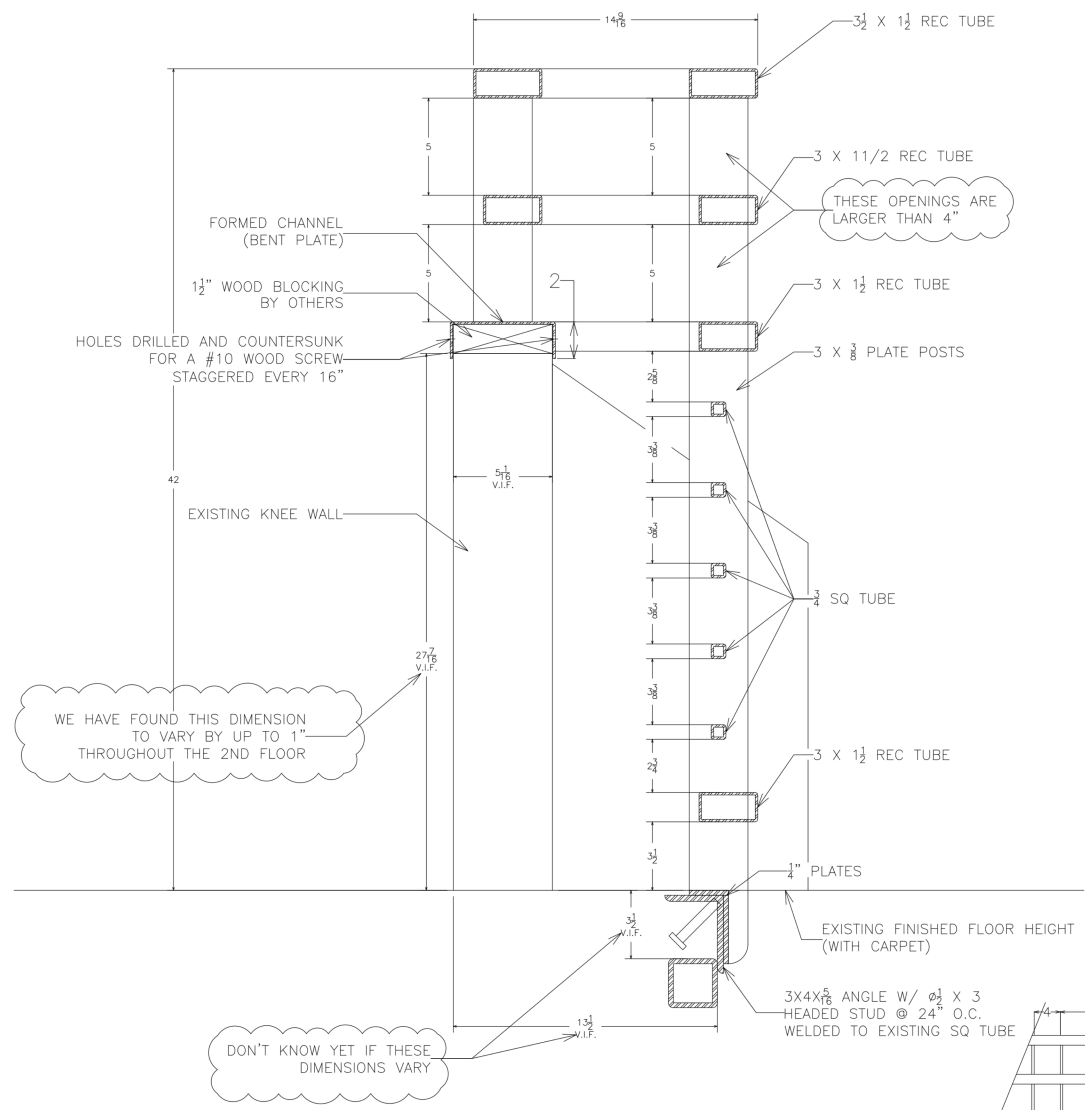

PLAN

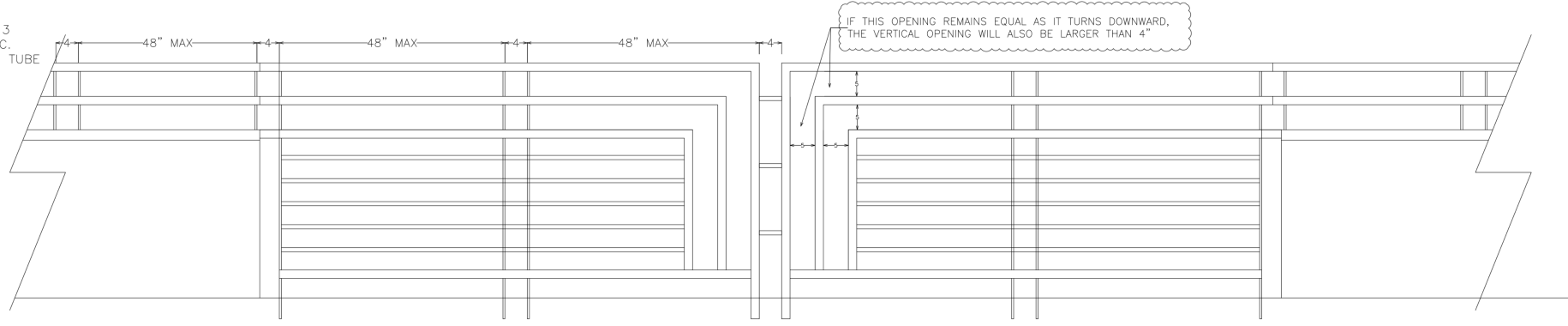

Our goal in the designing of these railings is to do so in such a way that we are building as few unique pieces as possible. After taking some preliminary measurements on the second floor we have run into these possible issues.

1. Due to the current height of the knee wall, to make the top of the rail the required 42" would make the openings between the three rectangular tubes at the top larger than 4"
 - a. If the openings where those tubes turn toward the bottom rail remain equal, they will also be larger than 4"
2. Where we measured, throughout the second floor, we found a variation in the height of the knee wall of up to 1". This makes it difficult to keep the rails on top of the knee wall a consistent height with the guardrails at the knee wall openings.
3. The location of the existing square tube to which we are to weld a 3 x 4 x 5/16" angle, may vary in both its horizontal and vertical placement. We won't know until they are all uncovered and measured.

BenFab, Inc.
 13 S. Highland Ave Lansdowne, PA 19050
 Phone: 610-626-9100 Fax: 610-626-9200
www.benfabrailings.com

Sullivan Triad Building
 200 Renaissance Blvd
 King of Prussia, PA

DRAWN: EY
 DATE: 2 / 14 / 2014
 REV: 1

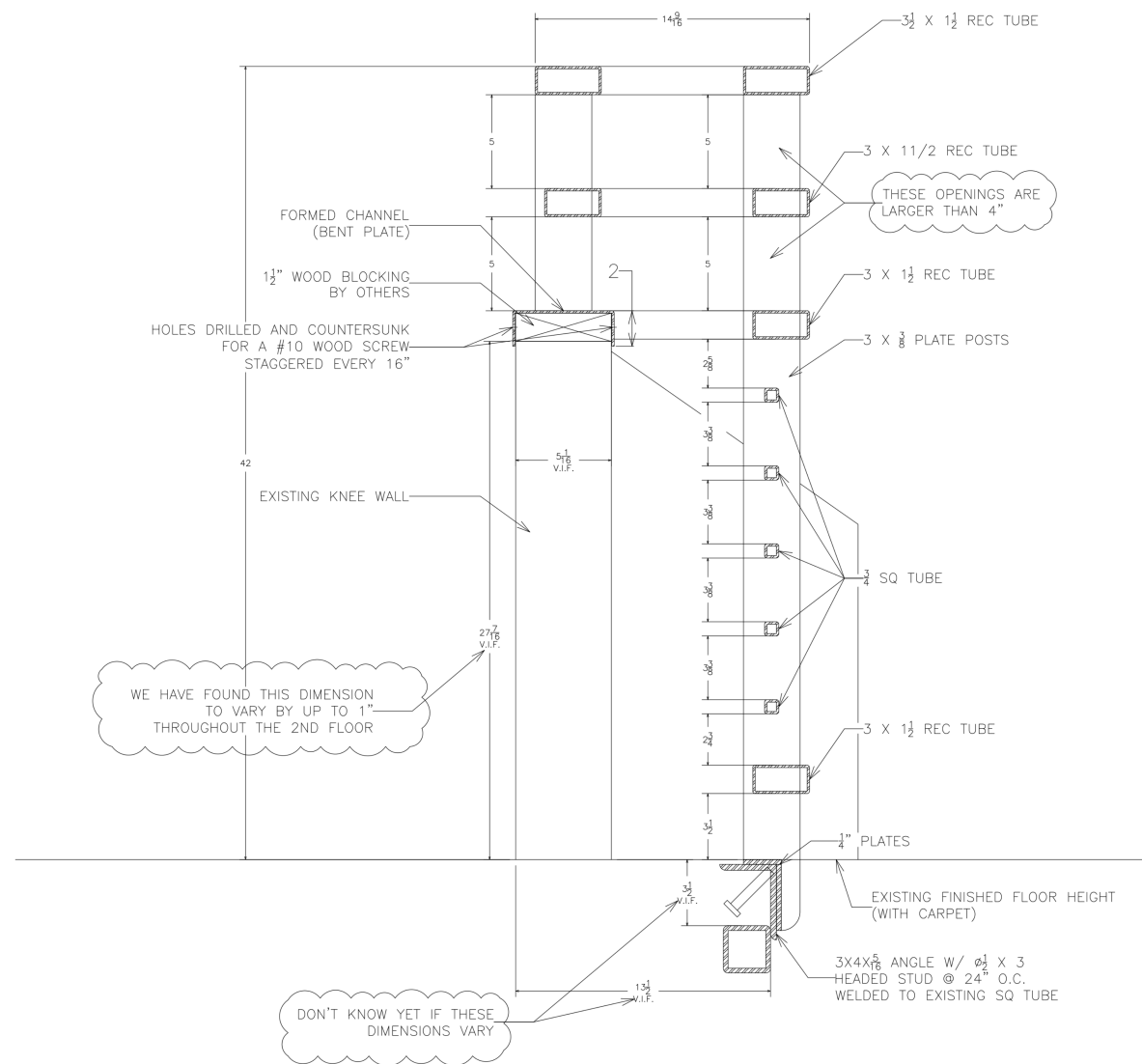

BenFab, Inc.
 13 S. Highland Ave Lansdowne, PA 19050
 Phone: 610-626-9100 Fax: 610-626-9200
www.benfabrailings.com

Sullivan Triad Building
 200 Renaissance Blvd
 King of Prussia, PA

DRAWN: EY

DATE: 2 / 14 / 2014

REV: 1

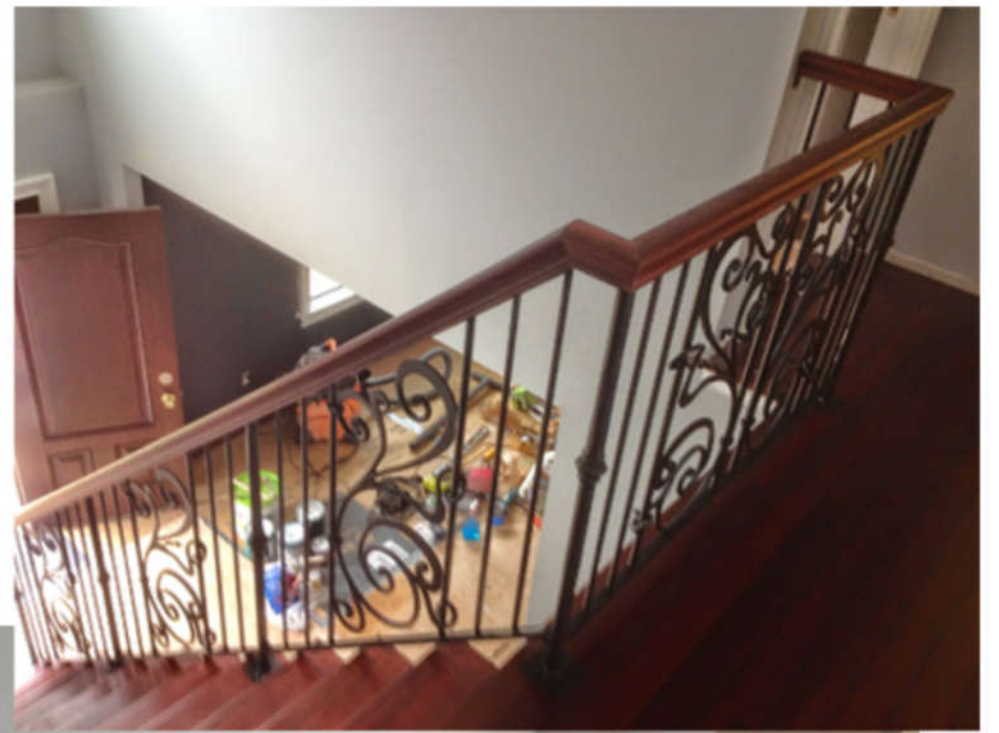

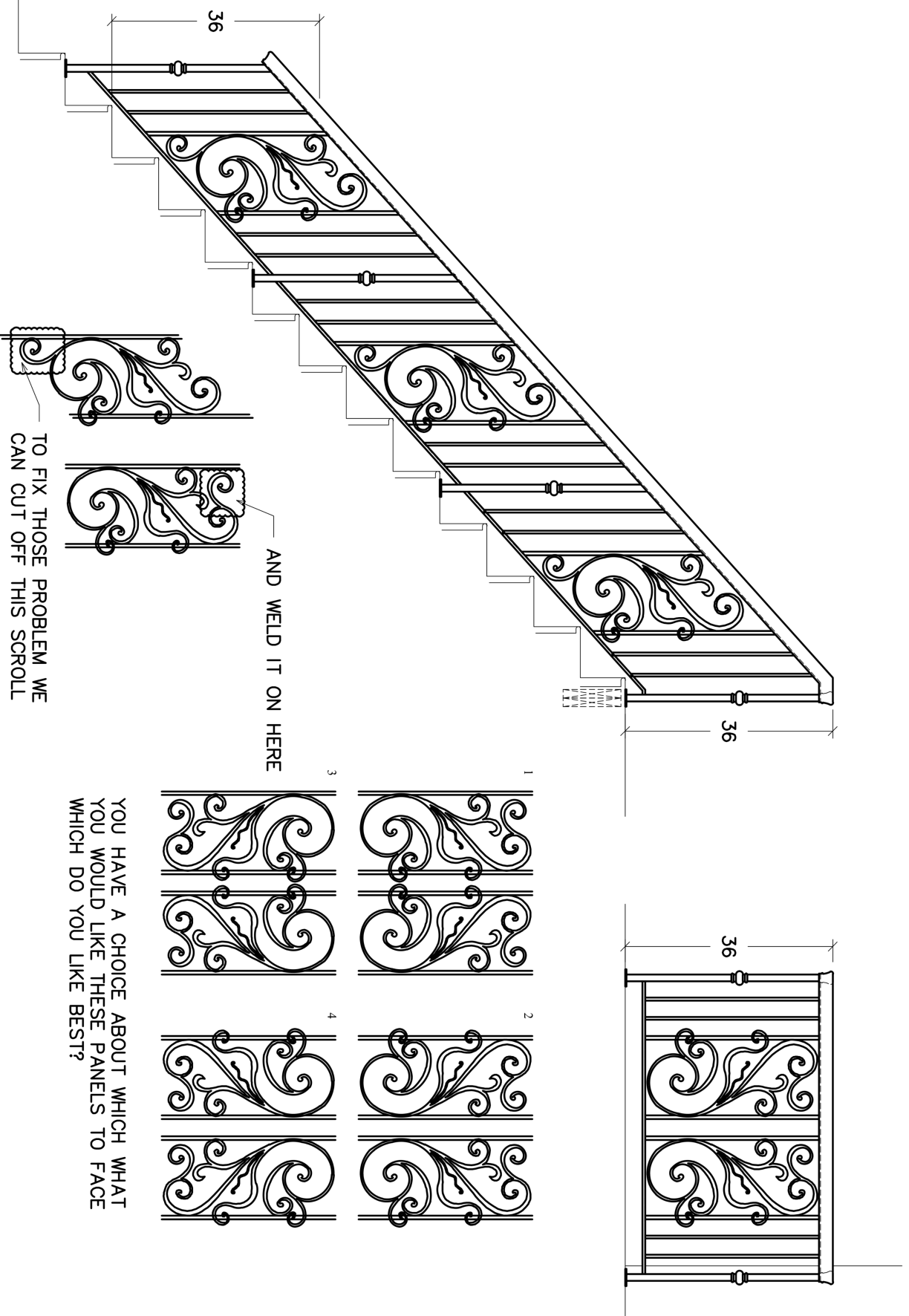
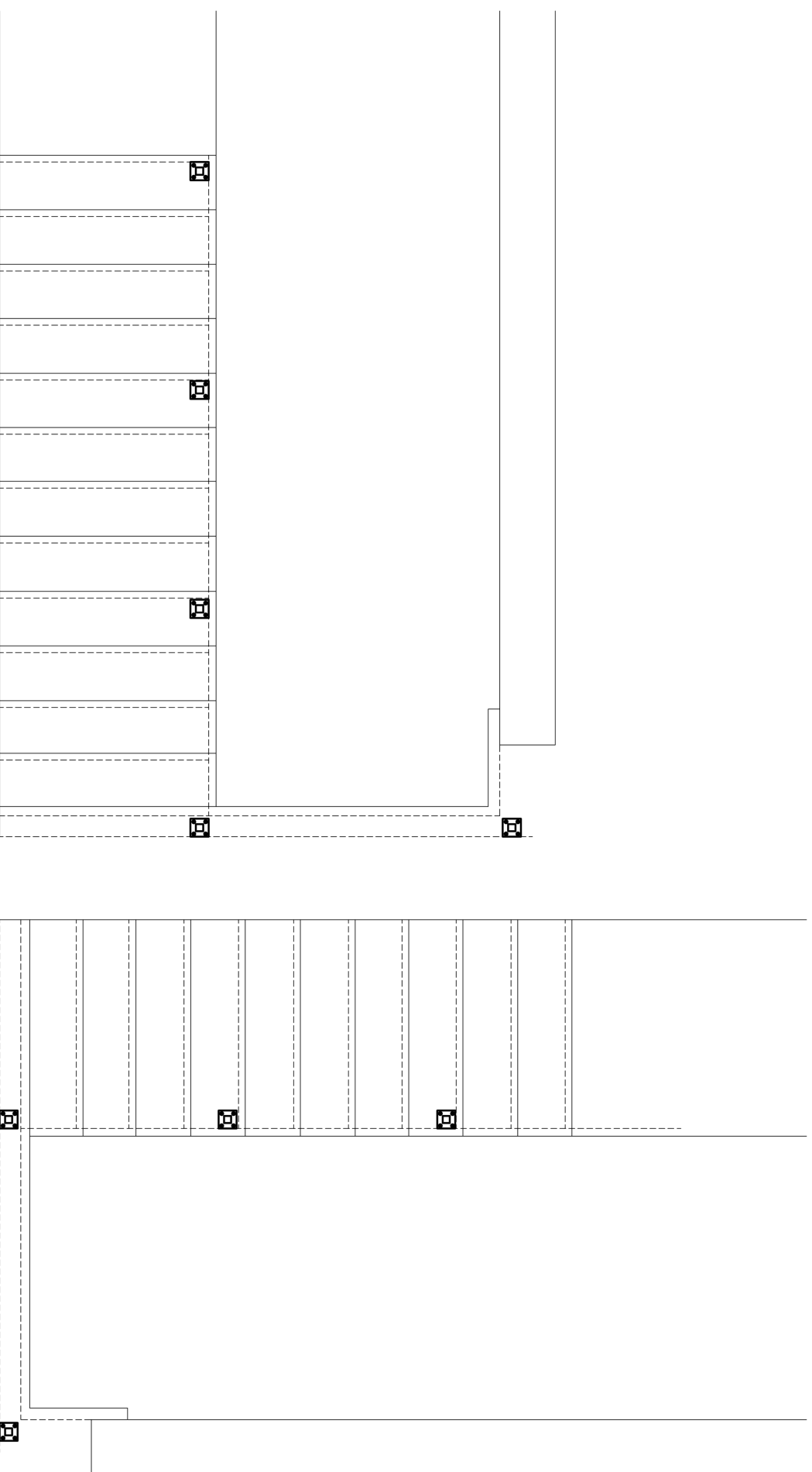

YOU HAVE A CHOICE ABOUT WHICH WHAT YOU WOULD LIKE THESE PANELS TO FACE WHICH DO YOU LIKE BEST?

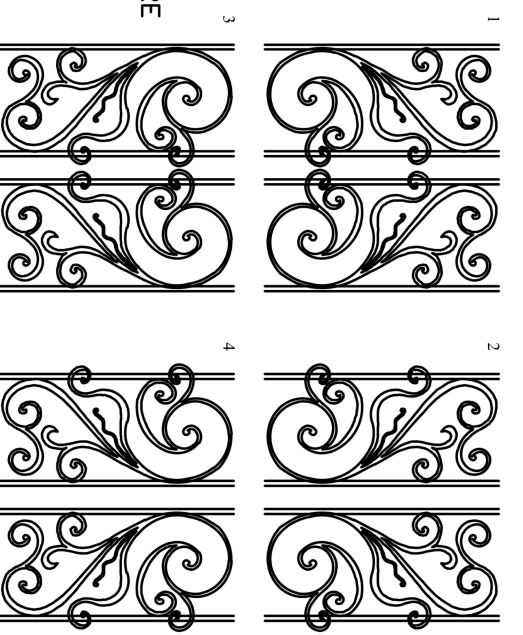

AND WELD IT ON HERE

TO FIX THOSE PROBLEM WE CAN CUT OFF THIS SCROLL

DRAWN: EY.
 DATE: 3/18/15
 REV: 0

BenFab, Inc.
 13 S. Highland Ave Lansdowne, PA 19050
 Phone: 610-626-9100 Fax: 610-626-9200
www.benfabrailings.com

Bellomo Residence

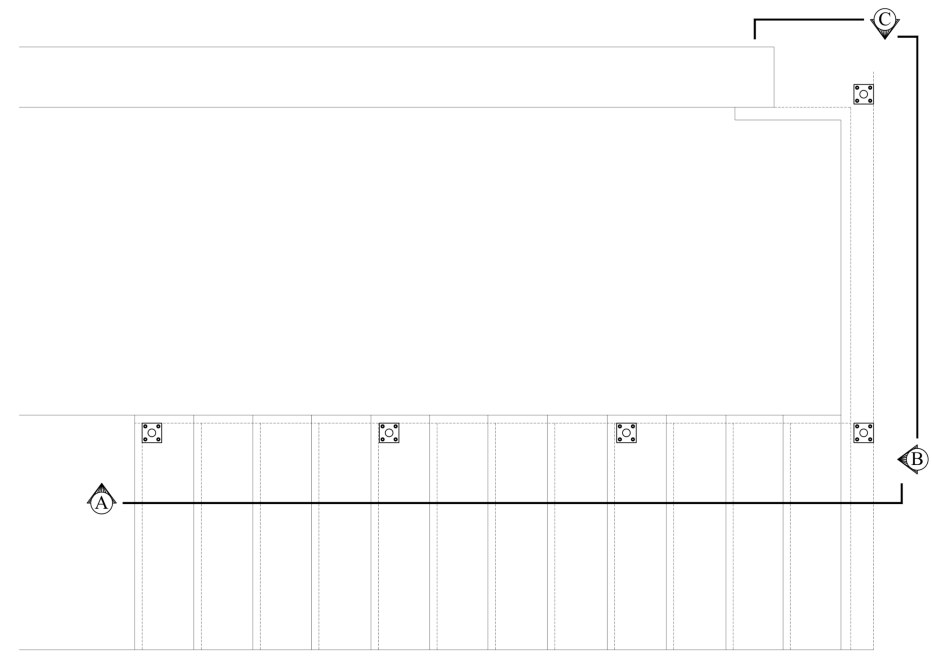
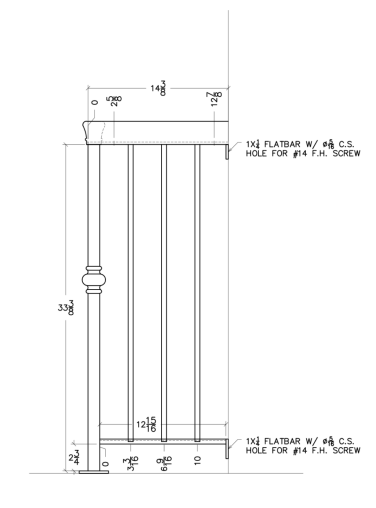
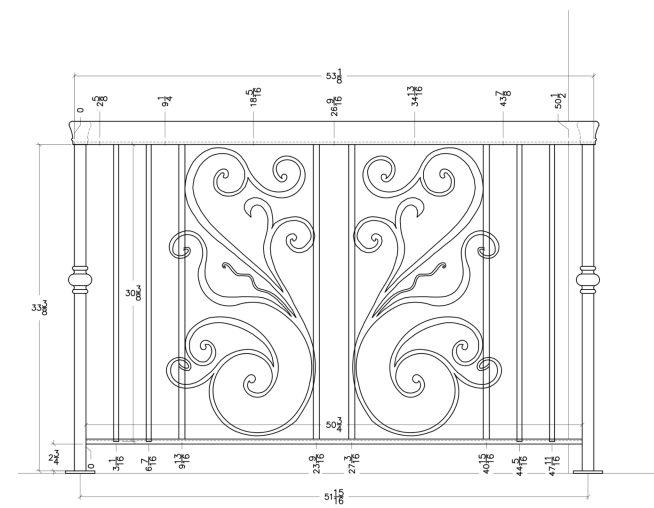
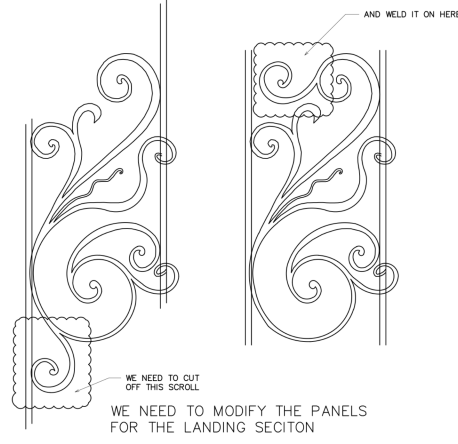
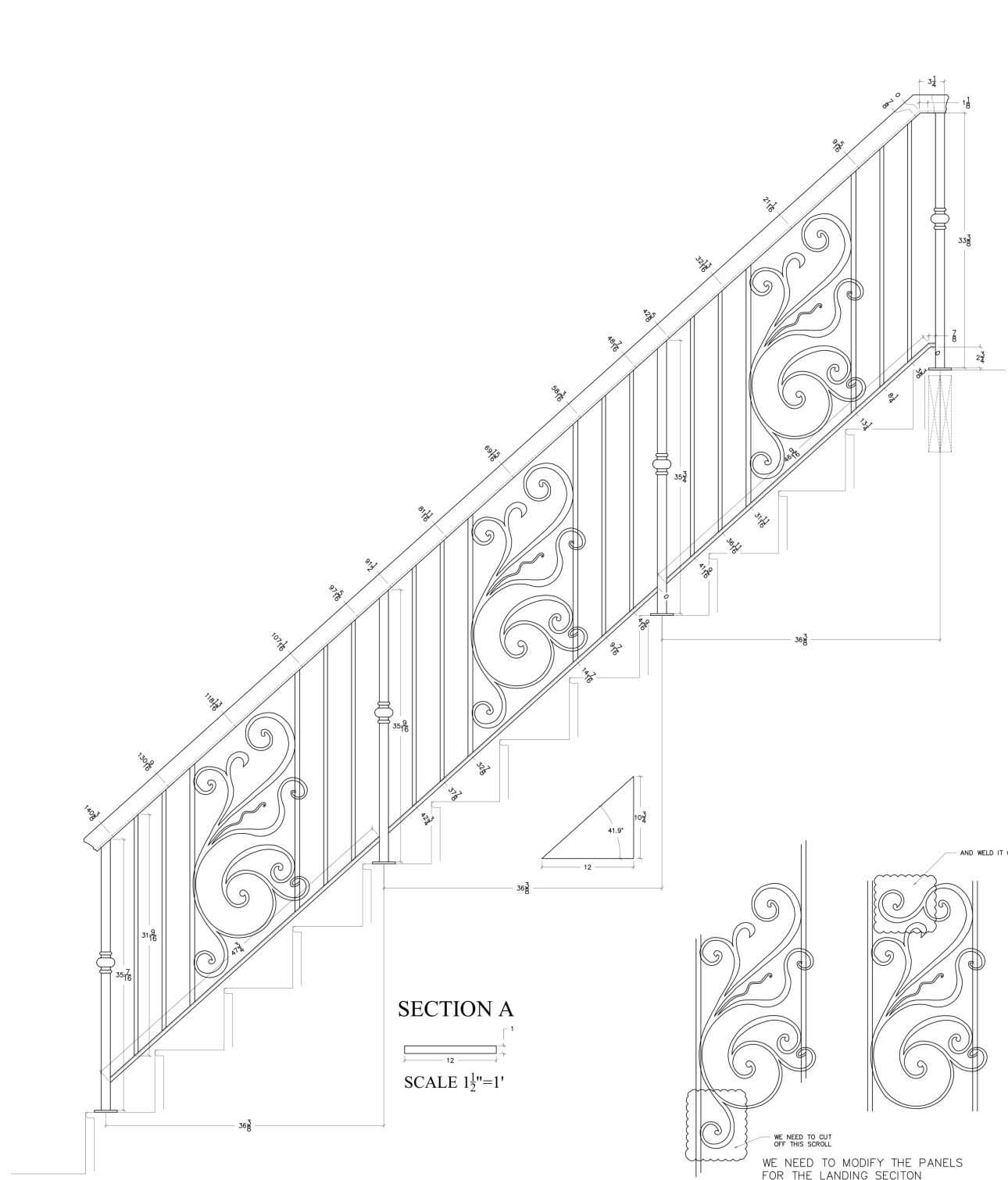

- MATERIALS:**
- TOP RAIL 1 1/2 x 1/4 FLATBAR
 - BOTTOM RAIL 1 x 1/2 x 1/8 CHANNEL
 - POSTS 1 3/8 ROUND FORGED POSTS
 - PICKETS 1/2" ROUND BAR
 - BASEPLATES ASK MIKE B.



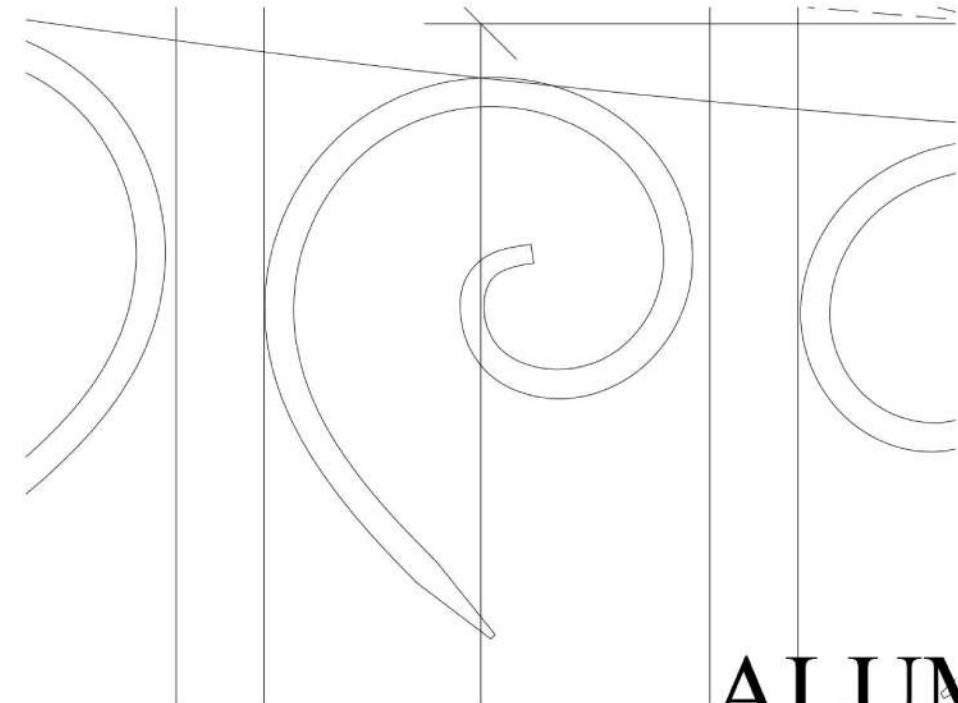
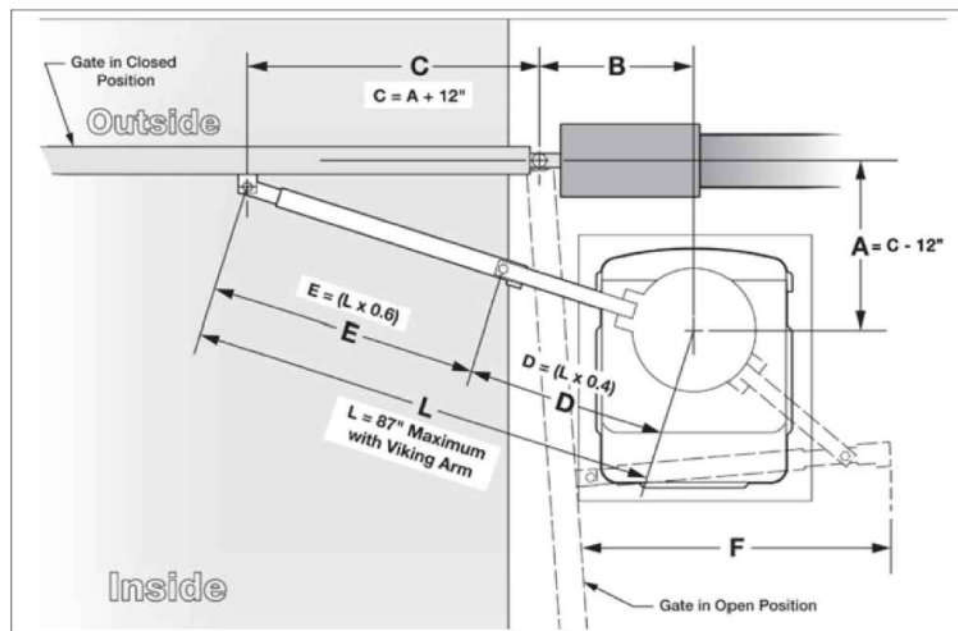
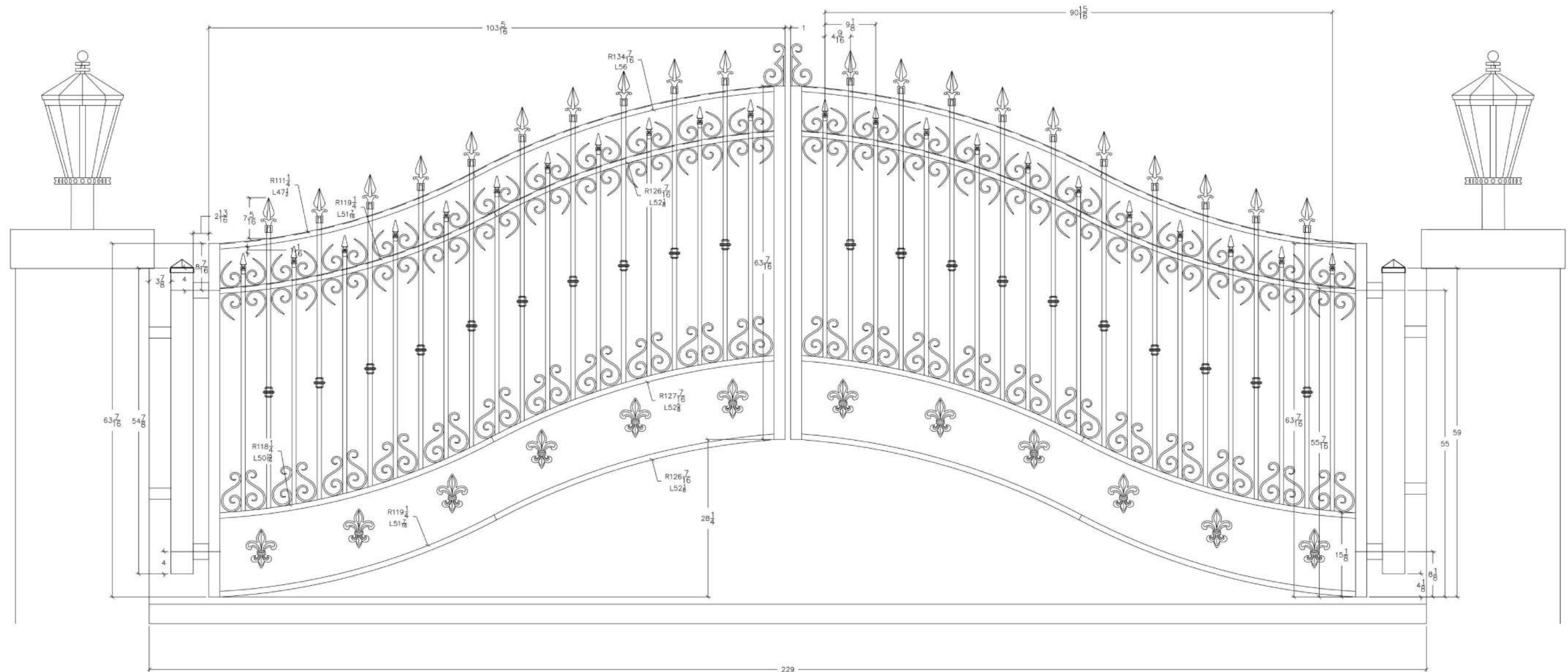

ALUM

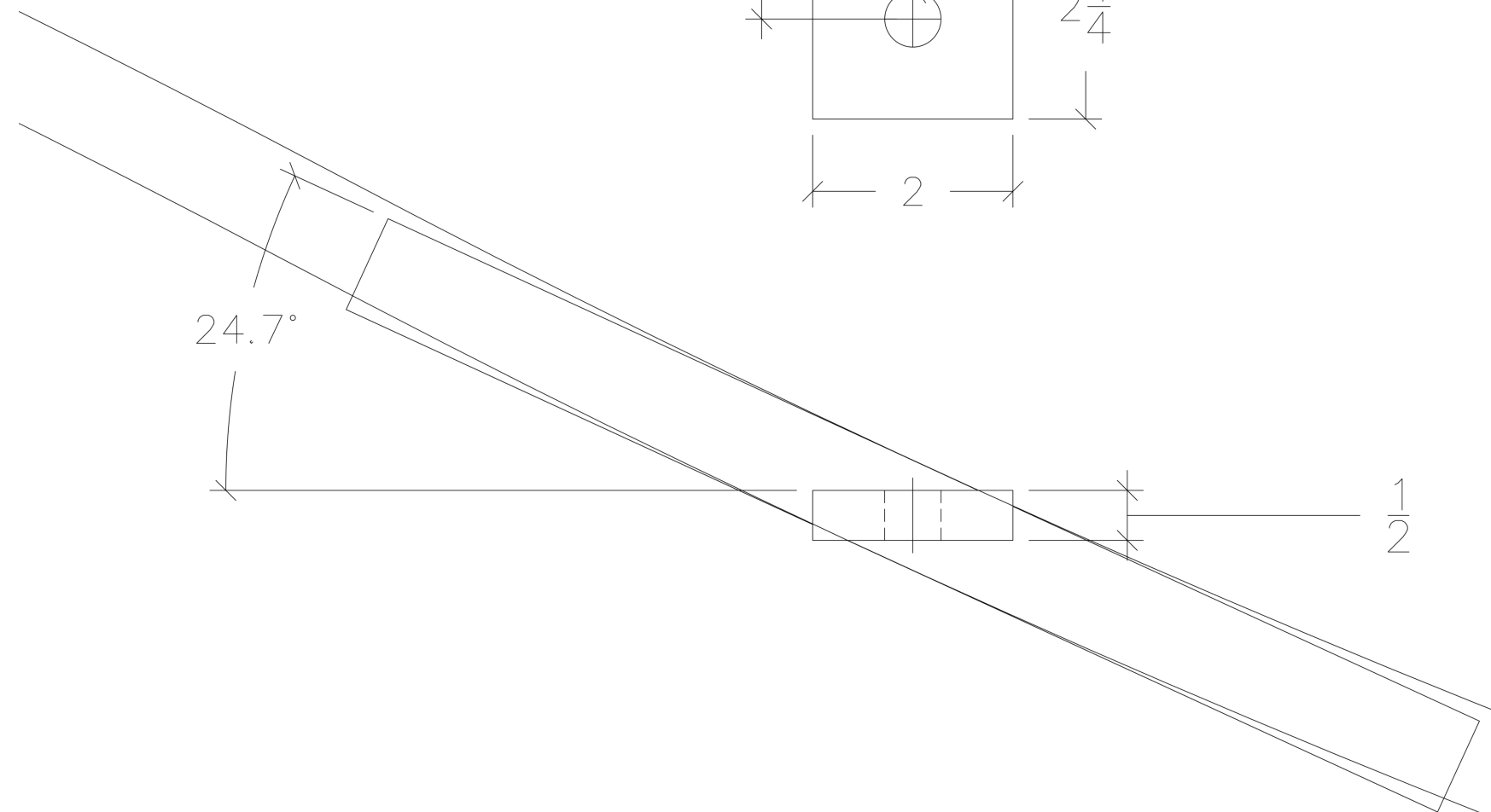
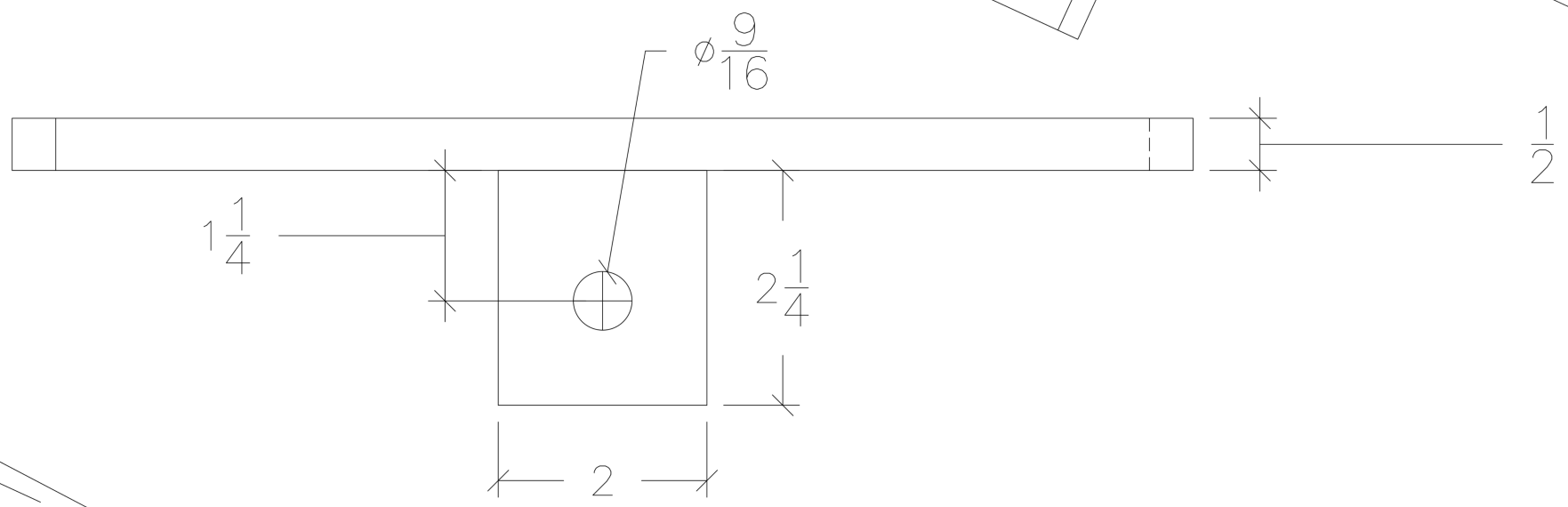
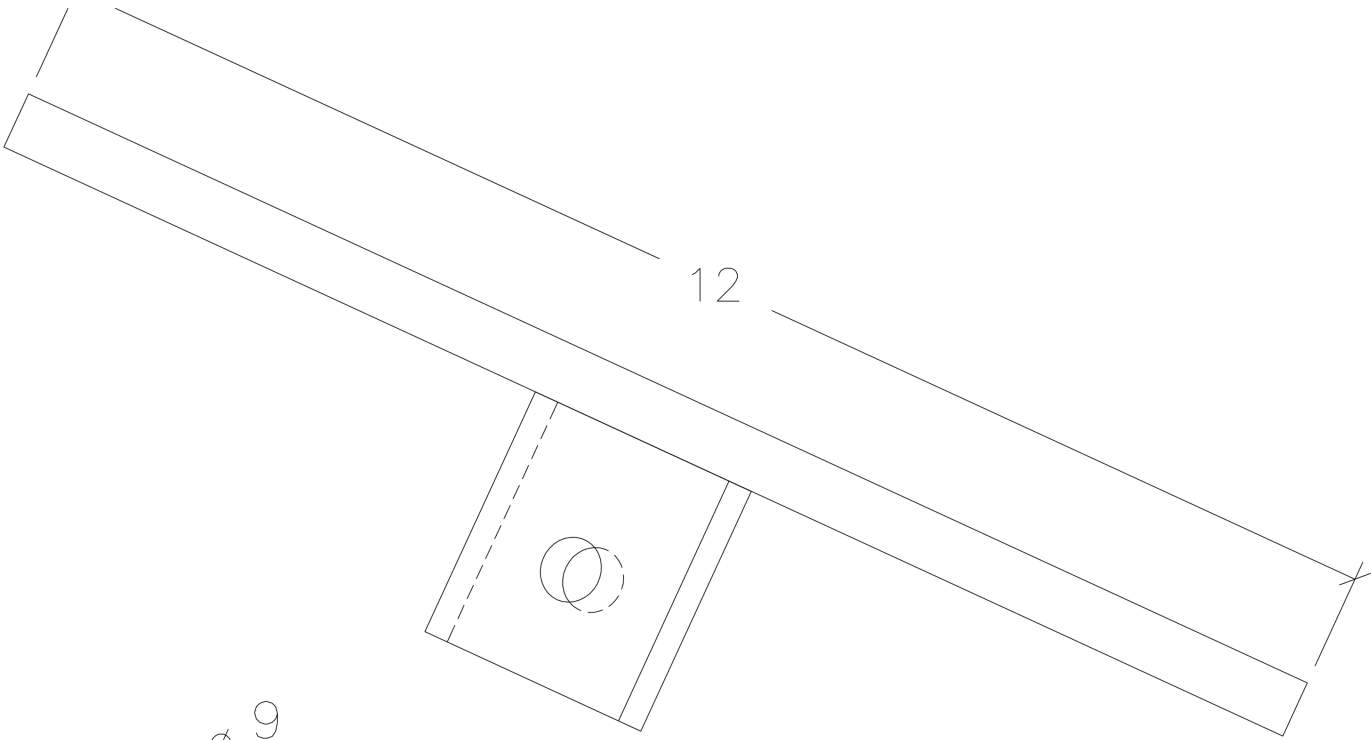

DRAWN: EY.	BenFab, Inc. 13 S. Highland Ave Lansdowne, PA 19050 Phone: 610-626-9100 Fax: 610-626-9200 www.benfabrailings.com	Quinn Driveway Gate
DATE: 8/13/14		Opener Footings
REV: 0		

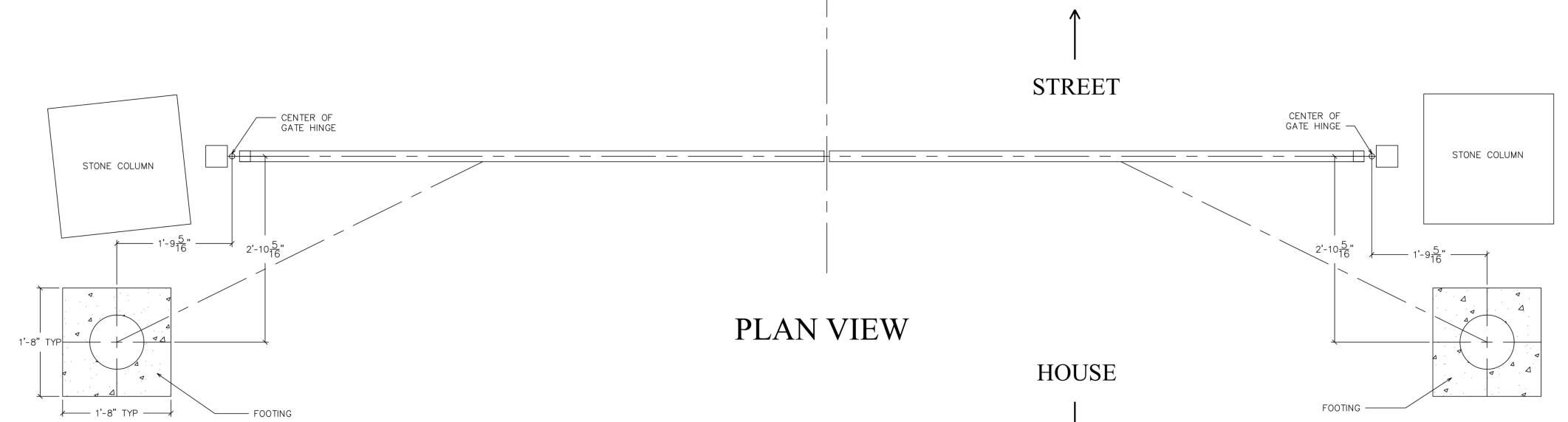
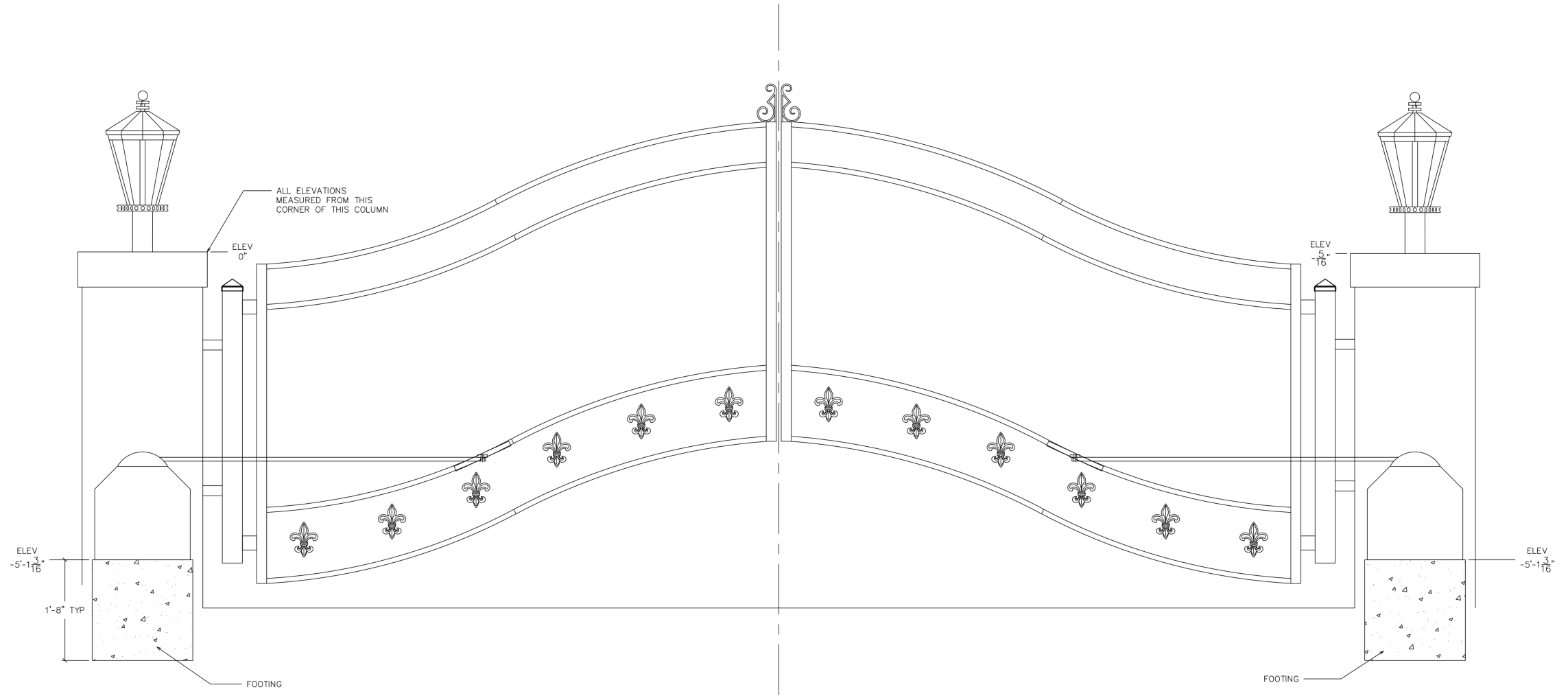

DRAWN: EY.	BenFab, Inc. 13 S. Highland Ave Lansdowne, PA 19050 Phone: 610-626-9100 Fax: 610-626-9200 www.benfabrailings.com	Quinn Driveway Gate
DATE: 8/13/14		Opener Footings
REV: 0		



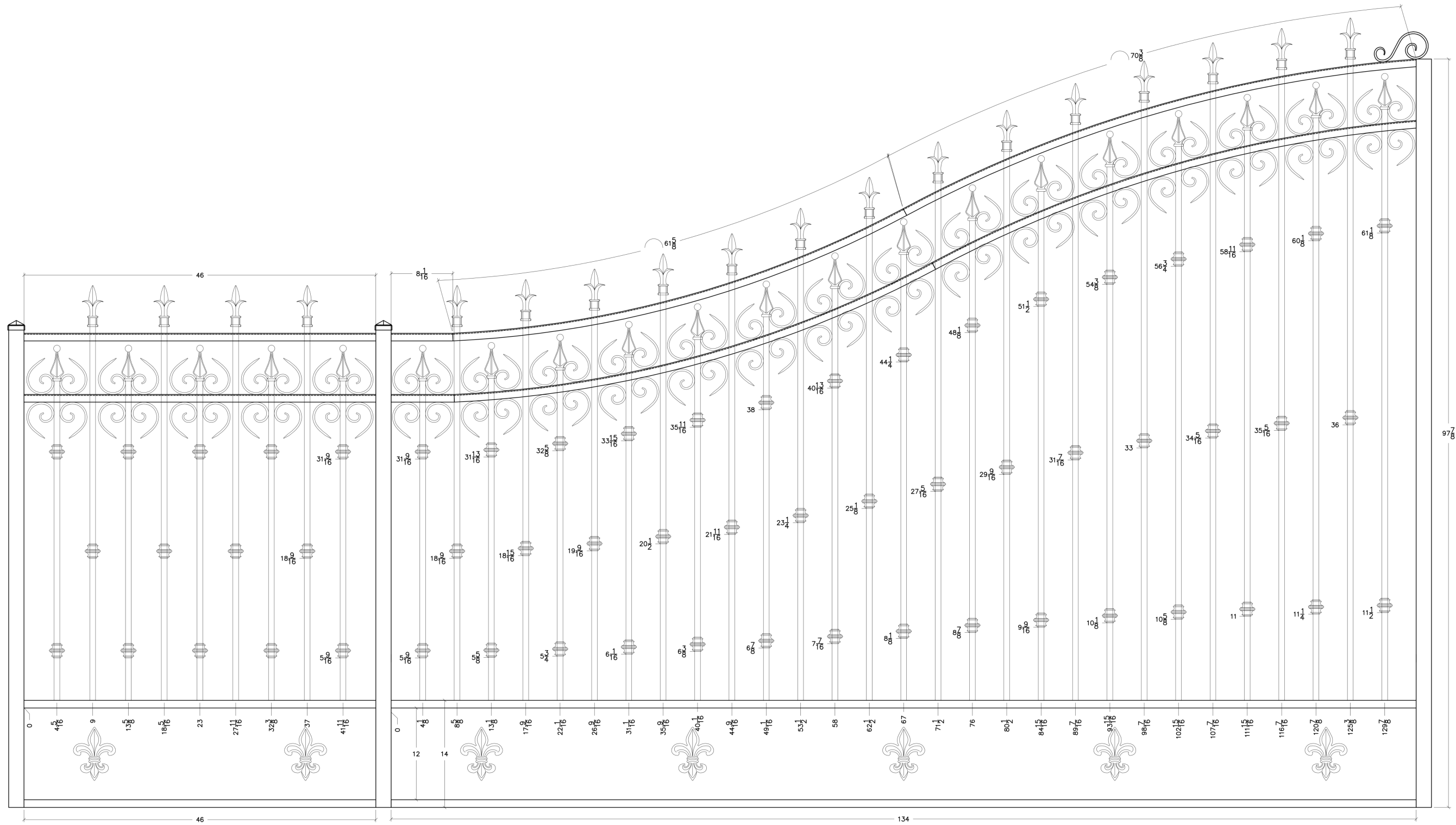

STEP RAILS ARE BOTH THE SAME, EXCEPT THE POST LENGTHS ARE DIFFERENT.

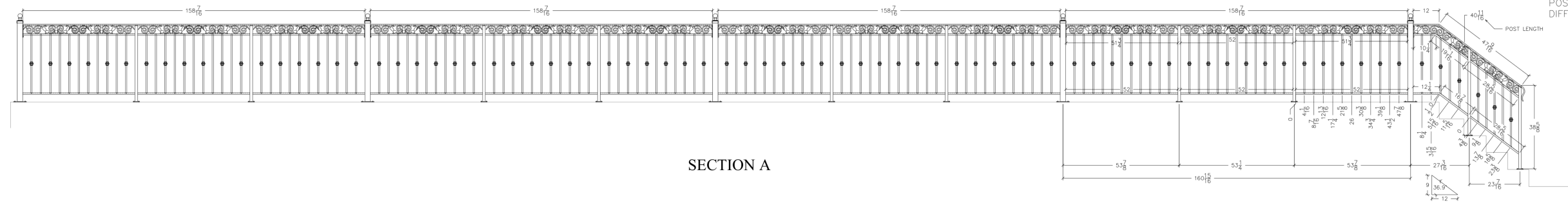

SECTION A

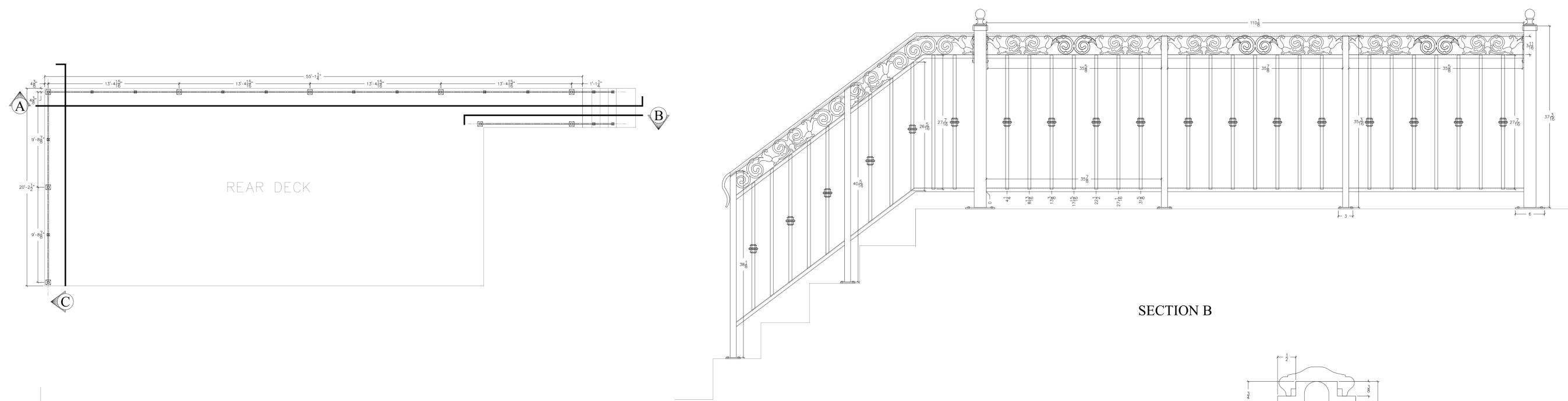

SECTION B

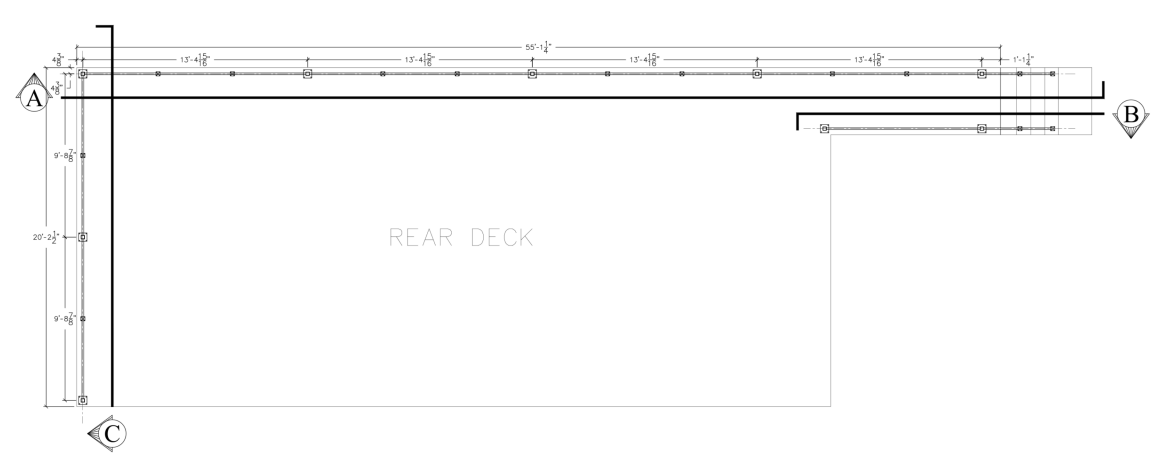

REAR DECK

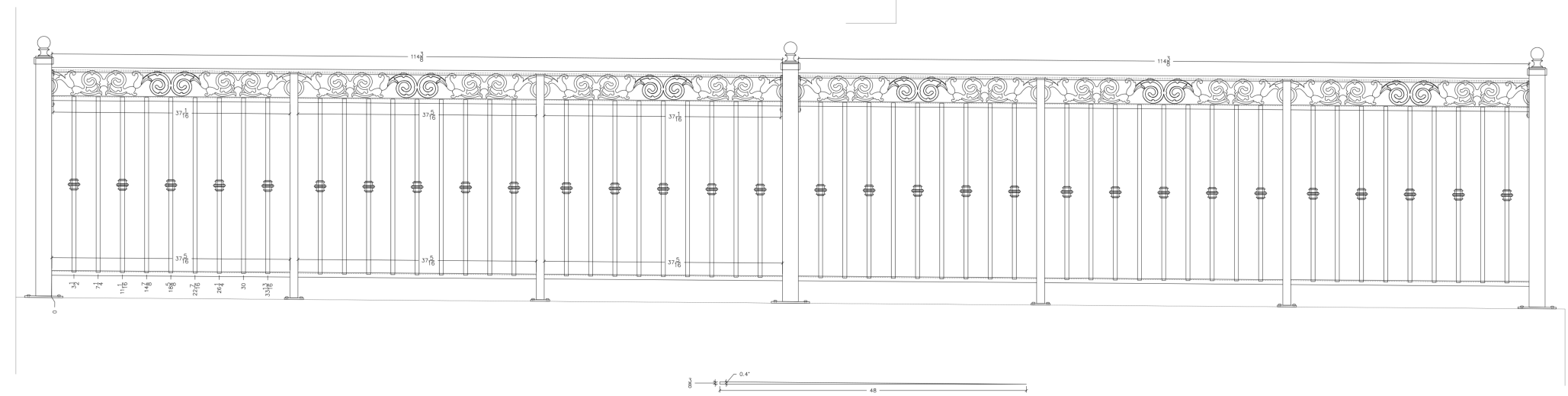

SECTION C

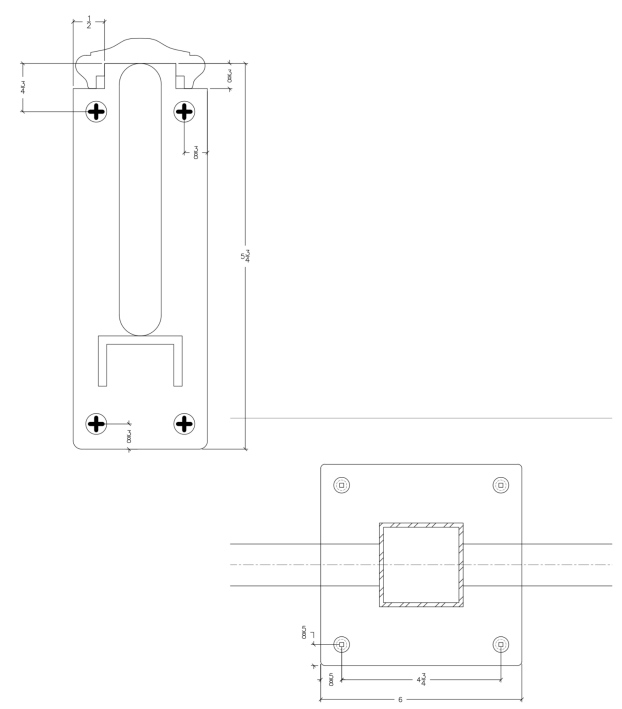

MATERIALS:

2.5" POSTS	26
1.25" POSTS	33
ATTACHMENT PLATE	47
6" BASEPLATE	26
3" BASEPLATE	33
PICKET W/ COLLAR	302
PICKET W/O COLLAR	245
FRIEZE	103
#14 PAN HEAD SCREWS	236
#10 PAN HEAD SCREWS	188

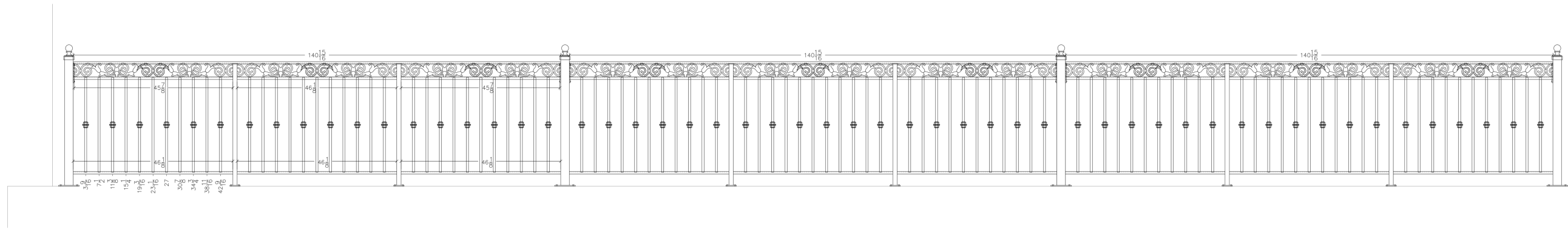

SECTION D

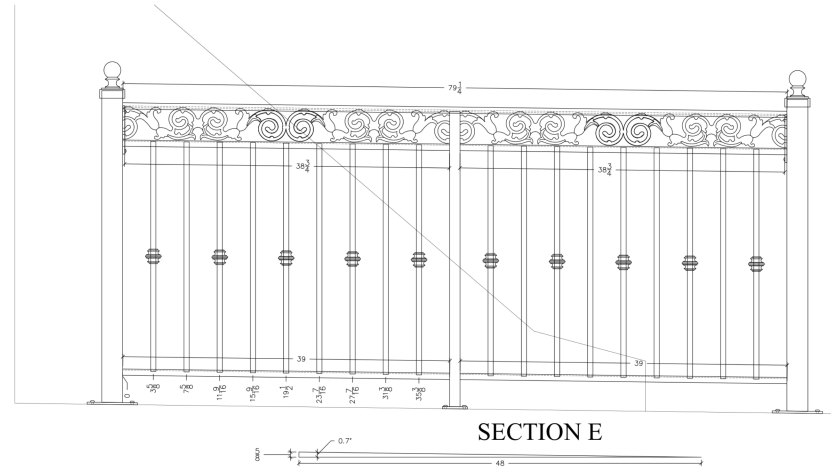

SECTION E

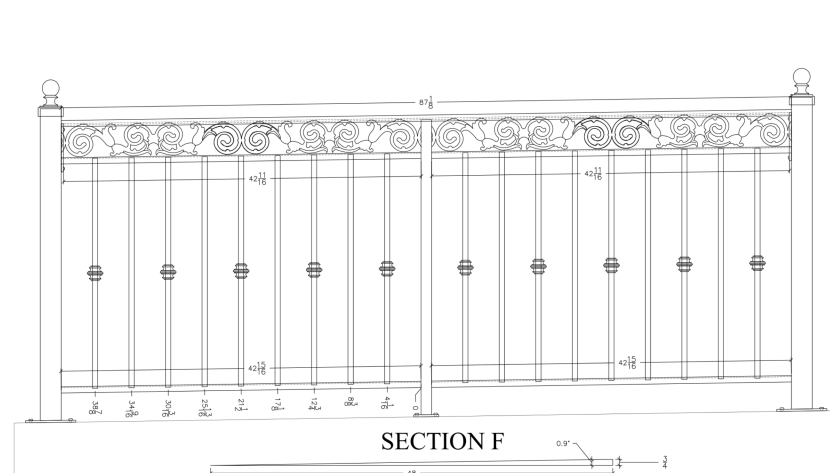

SECTION F

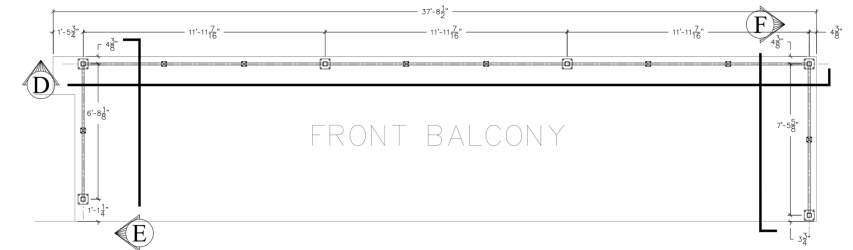

FRONT BALCONY

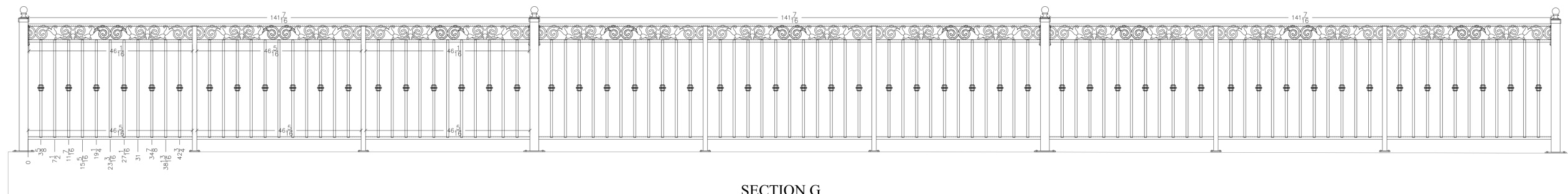

SECTION G

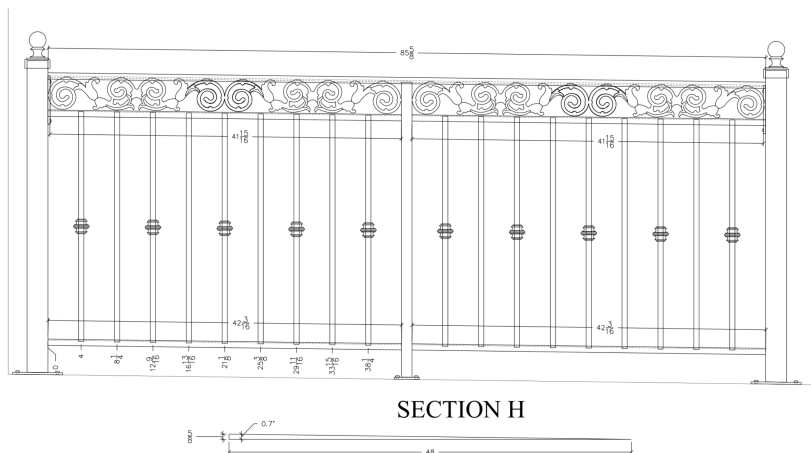

SECTION H

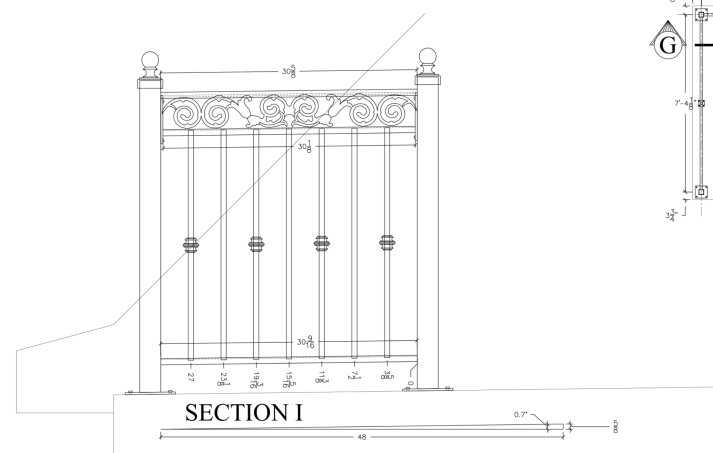

SECTION I

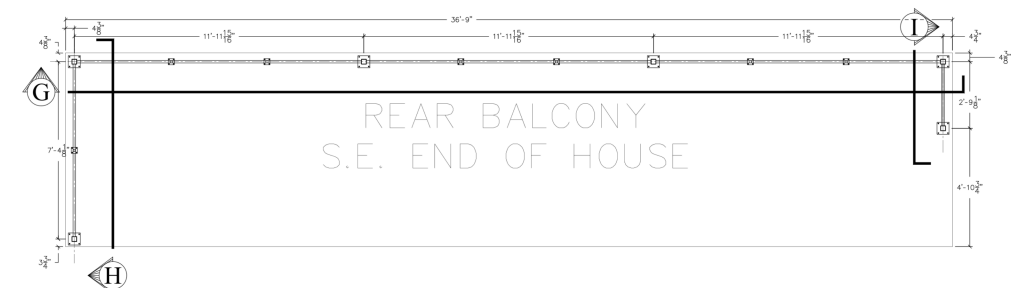

REAR BALCONY
S.E. END OF HOUSE

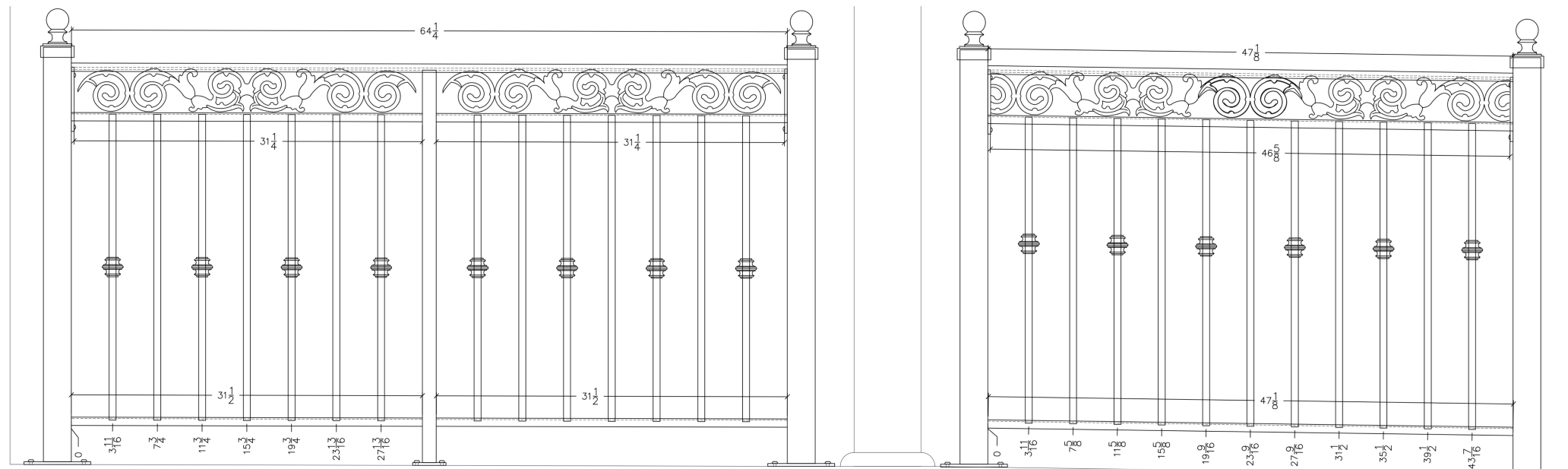

SECTION J

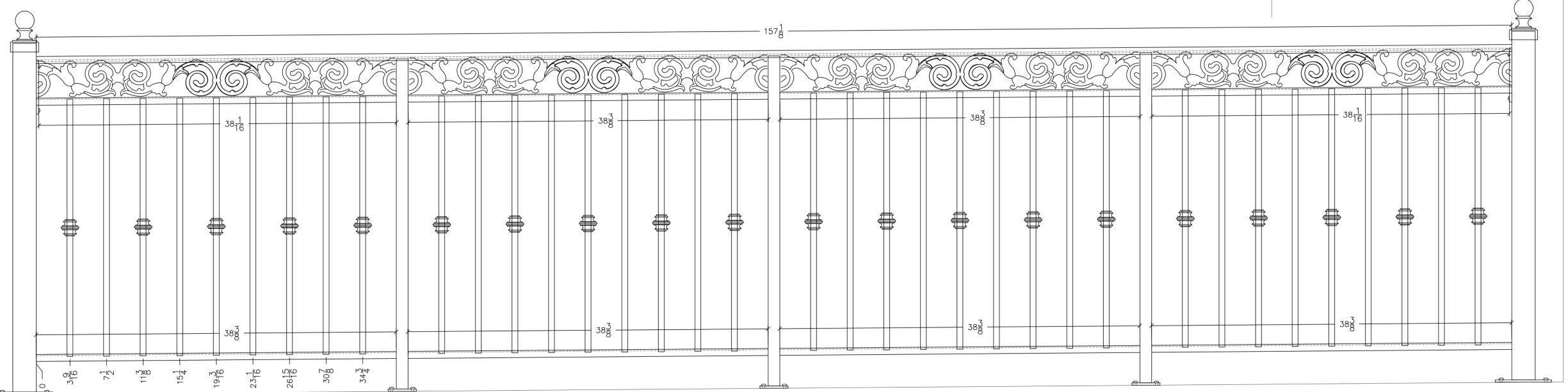

SECTION K

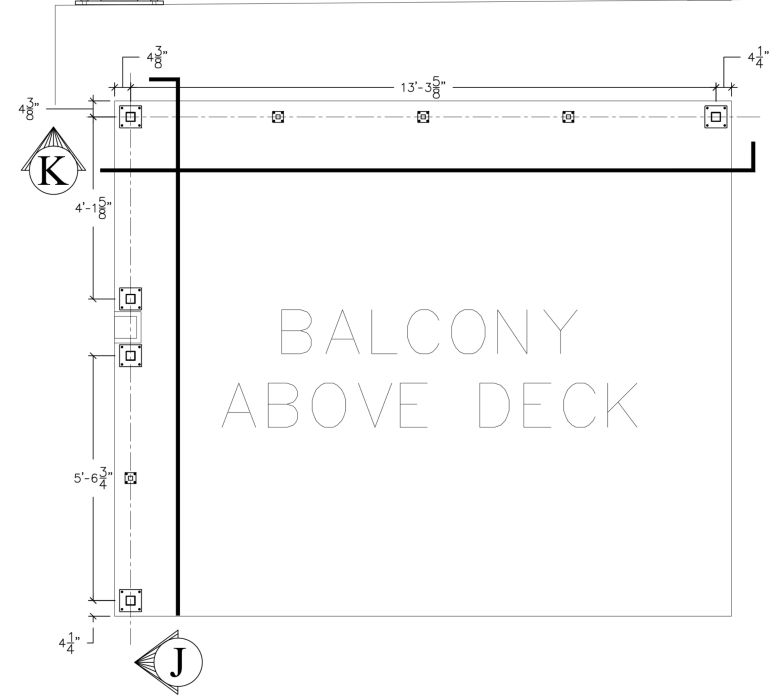
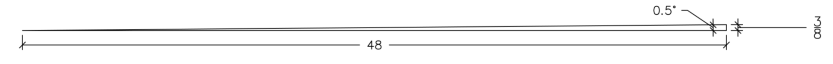

BALCONY
ABOVE DECK

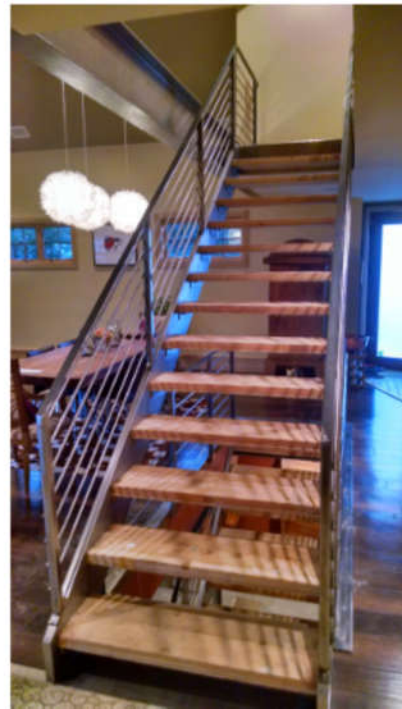
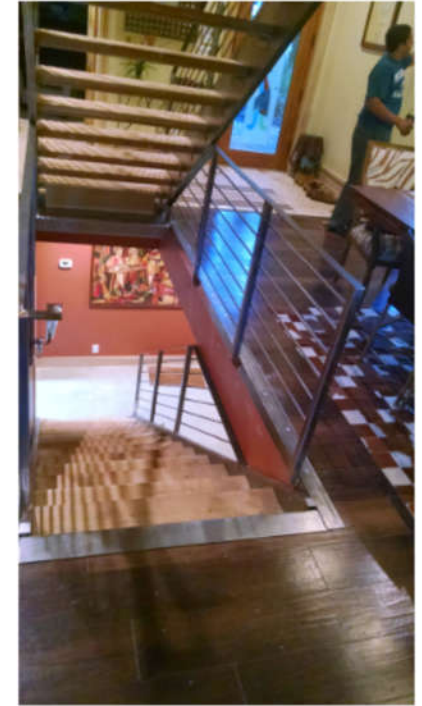
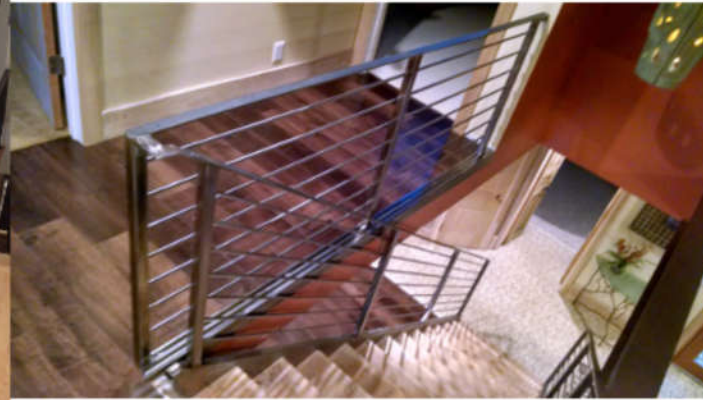
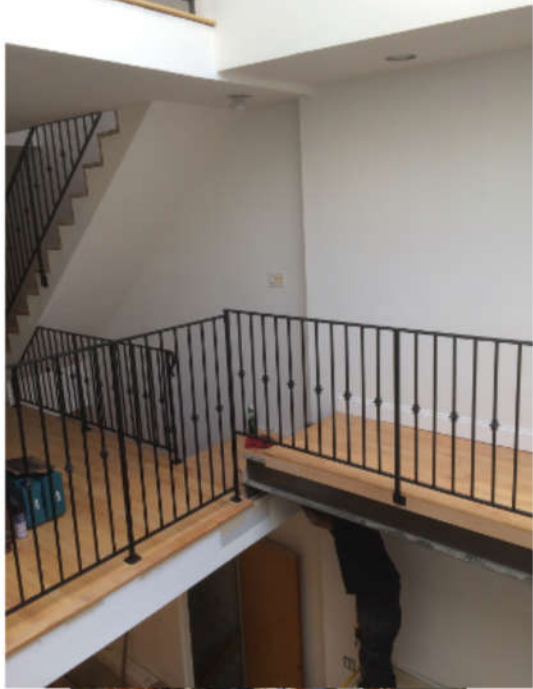
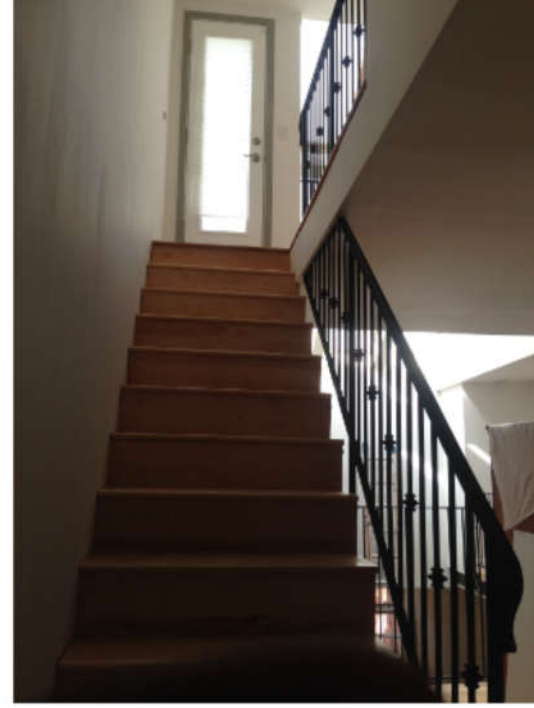
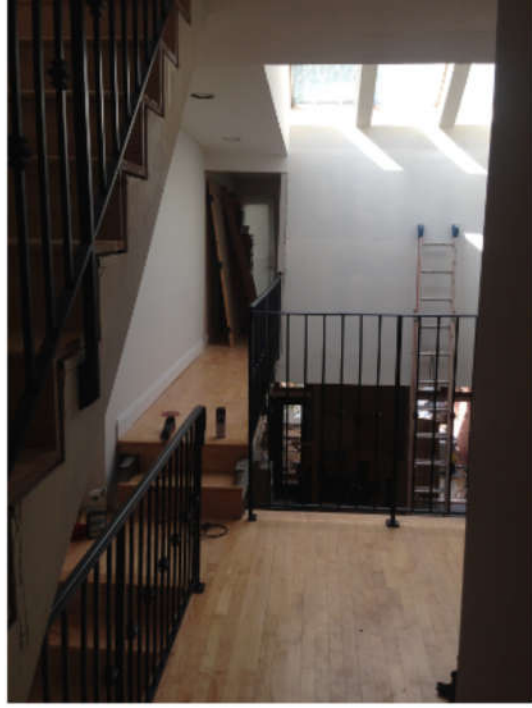
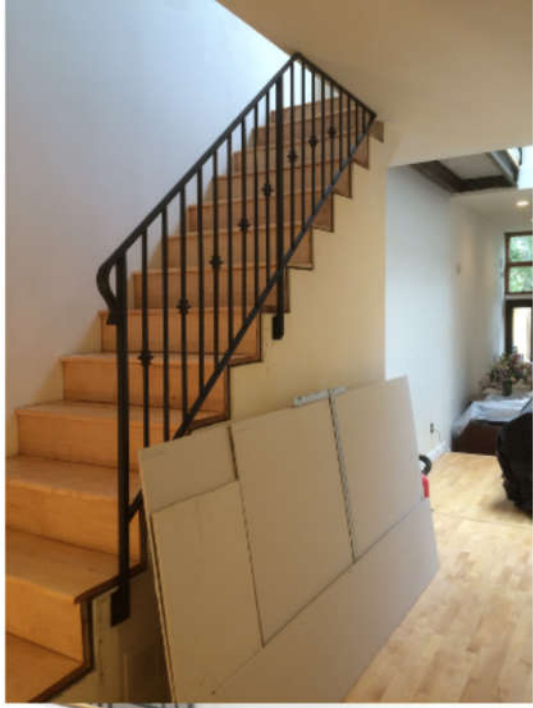

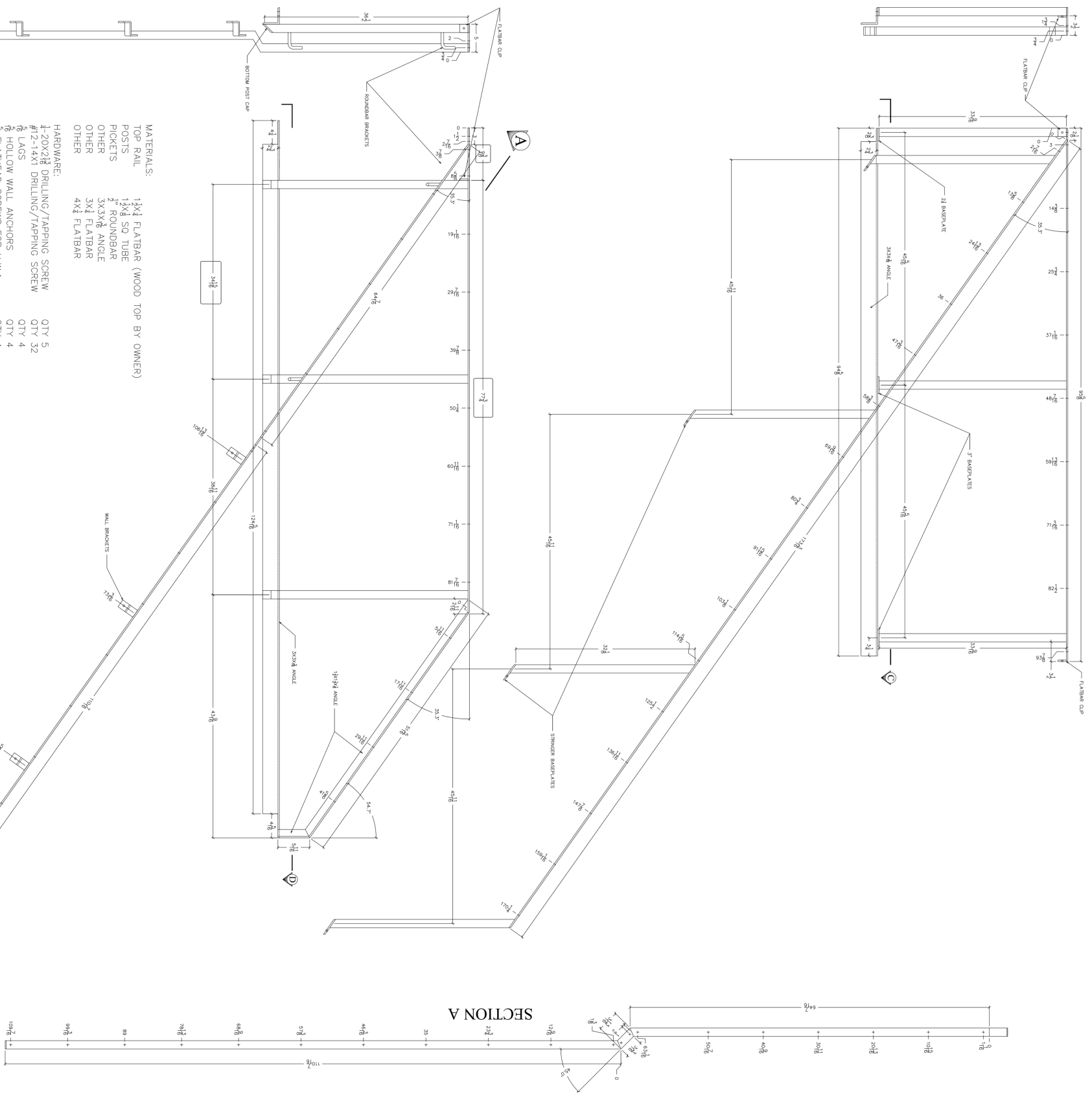
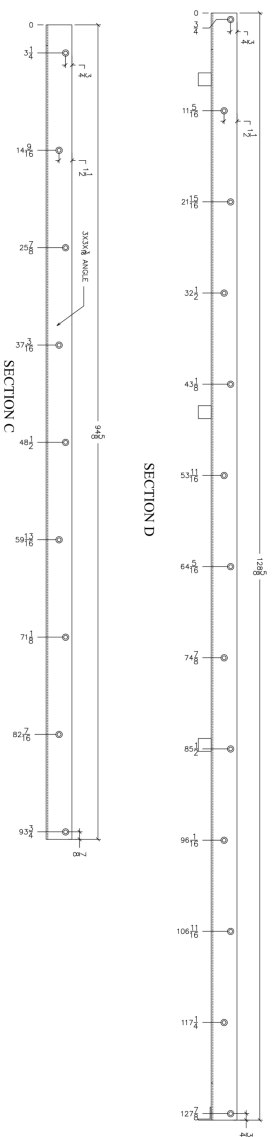

- MATERIALS:**
- | | |
|----------|---------------------------------|
| TOP RAIL | 1x4 FLATBAR (WOOD TOP BY OWNER) |
| POSTS | 1x4 SO. TUBE |
| POCKETS | 2" ROUND BAR |
| OTHER | 3x3x8 ANGLE |
| OTHER | 3x4 FLATBAR |
| OTHER | 4x4 FLATBAR |
- HARDWARE:**
- | | |
|-------------------------------------|--------|
| 1/2-20x2 1/8 DRILLING/TAPPING SCREW | QTY 5 |
| #12-14x1 DRILLING/TAPPING SCREW | QTY 32 |
| 1/8 LAGS | QTY 4 |
| 1/8 HOLLOW WALL ANCHORS | QTY 4 |
| 1/8 FLATHEAD SCREWS FOR H.W.A. | QTY 4 |
| 3/8 FLATHEAD SLEEVE ANCHOR | QTY 44 |

- NOTES:**
- FLATBAR TOP RAIL GETS 3/4" COUNTERSUNK HOLES FOR WOOD SCREWS TO MOUNT WOOD TOP
 - 1x4 1/2" ANGLE GETS #11 COUNTERSUNK HOLES FOR #12 FLATHEAD SCREWS
 - 4x4 FLATBAR GETS 3/4" COUNTERSUNK HOLES FOR 1/20 FLATHEAD SCREW

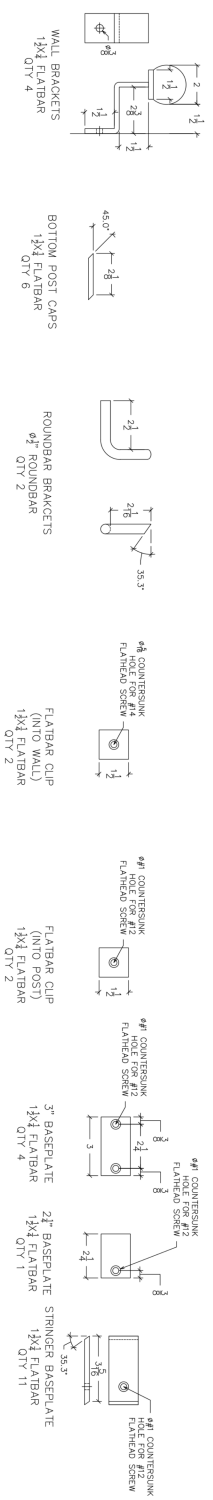

STEEL

RAIL

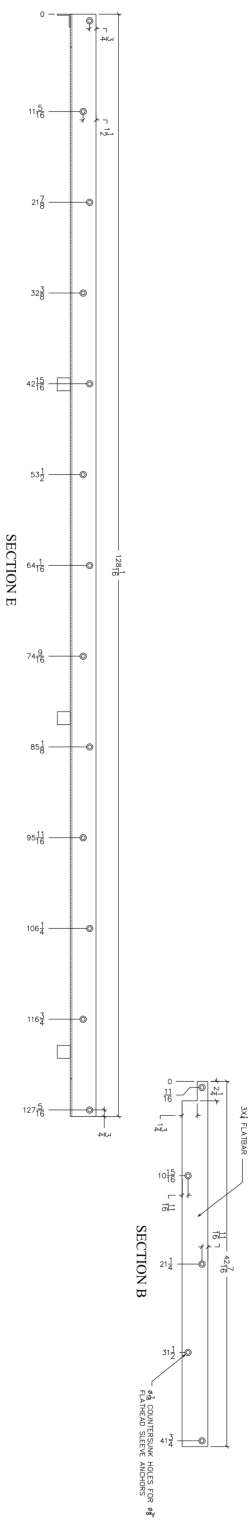

SECTION E

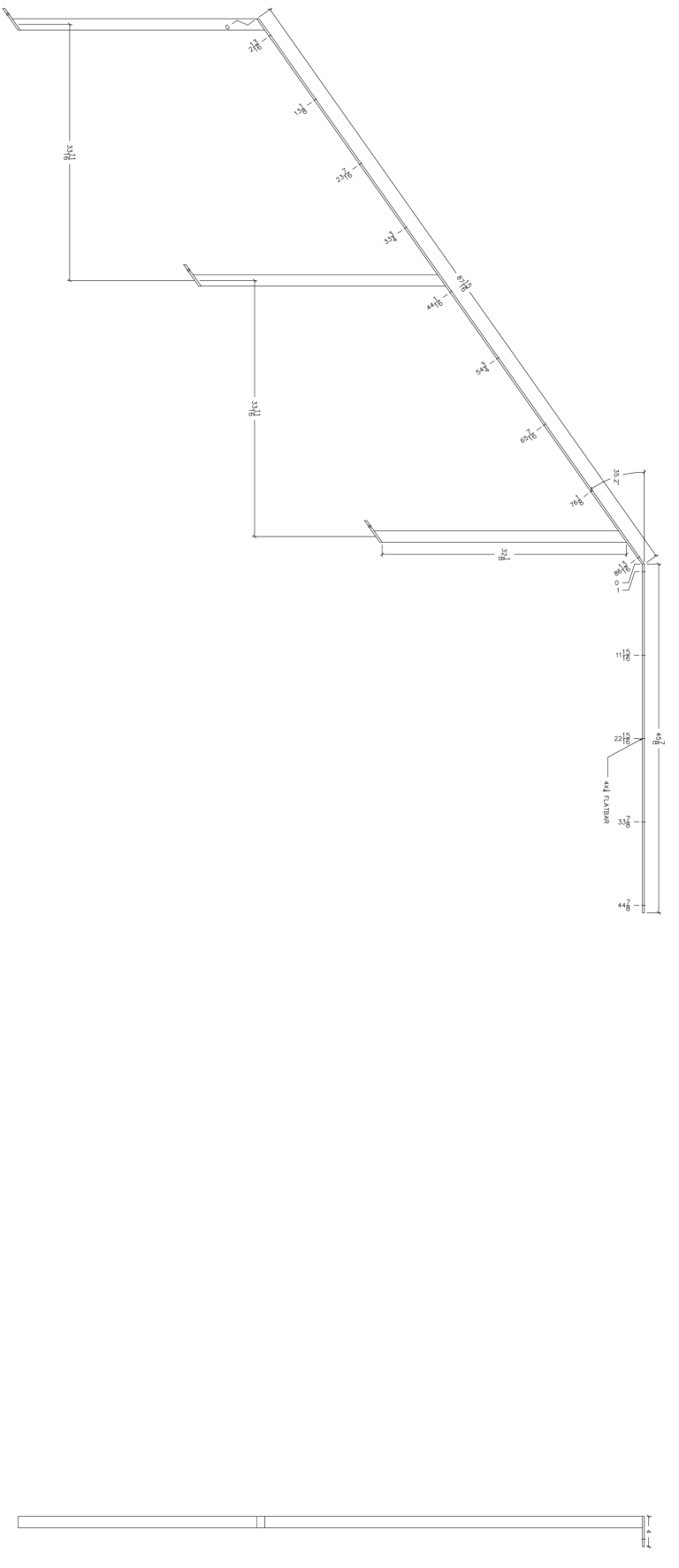
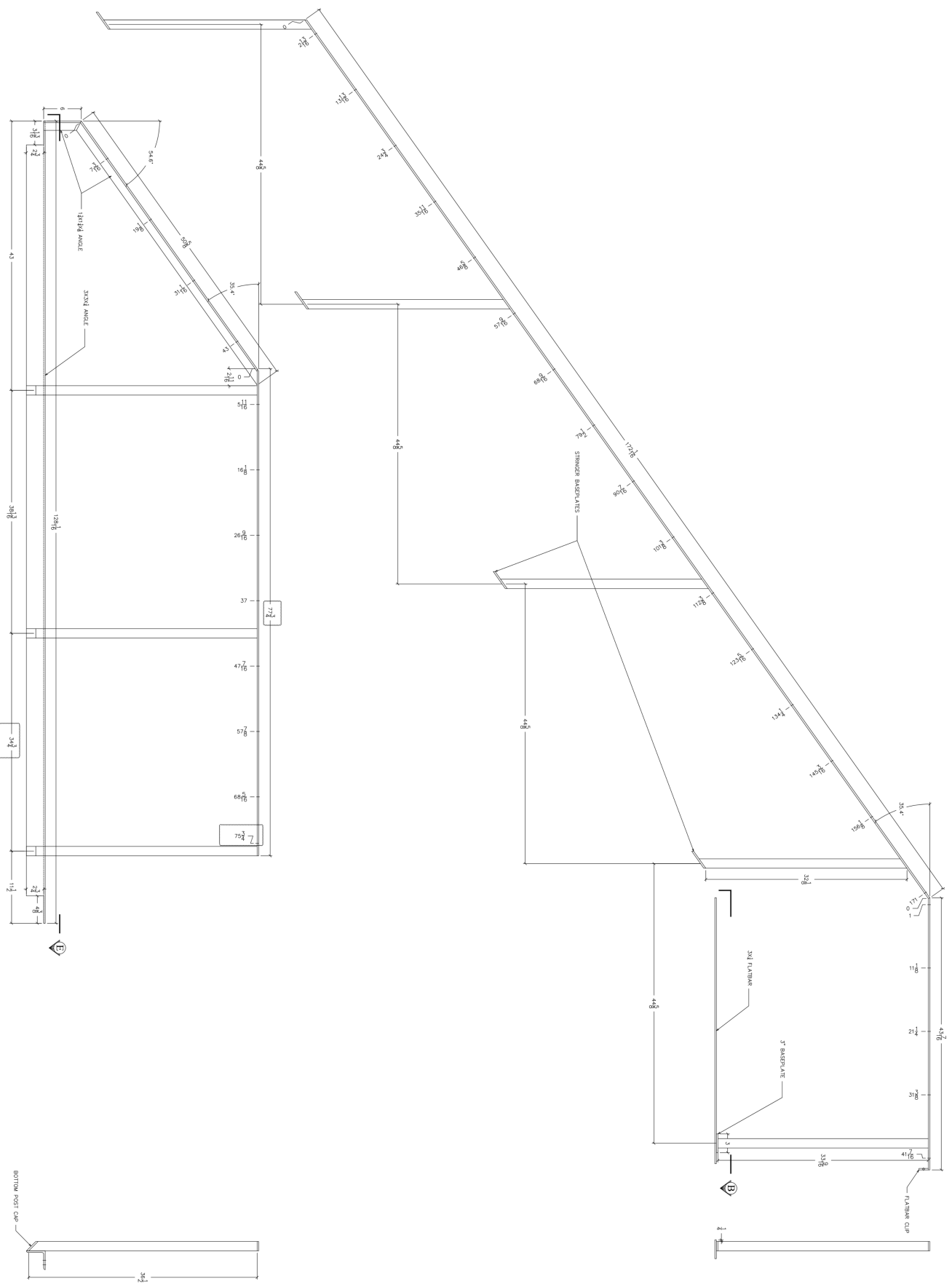

RAIL

STEEL

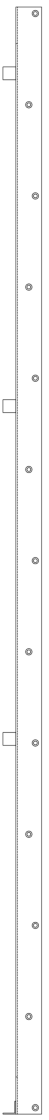

SECTION D

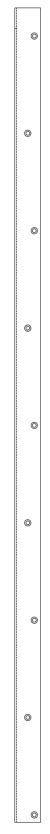

SECTION C

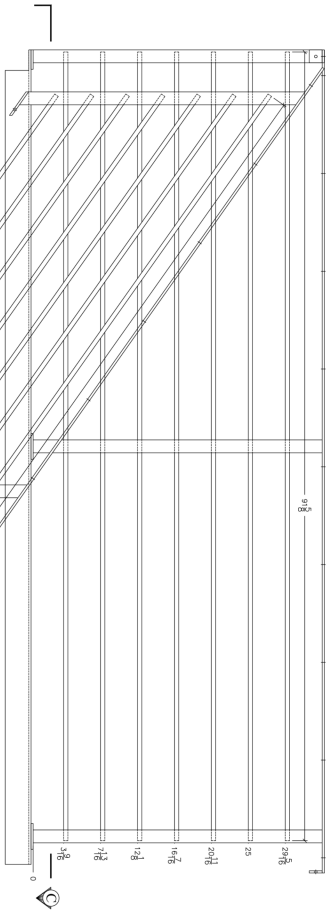
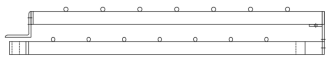

SECTION A

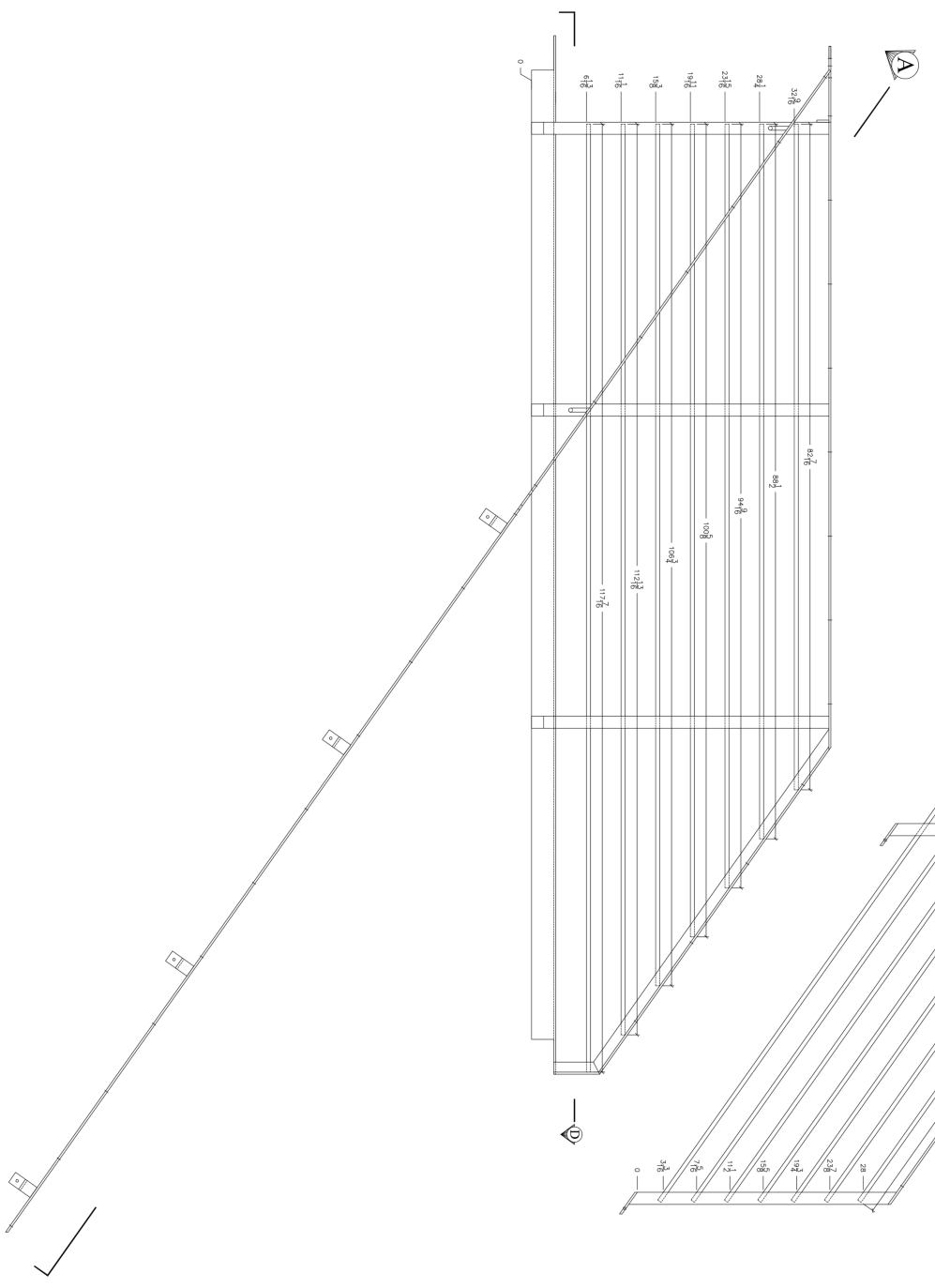
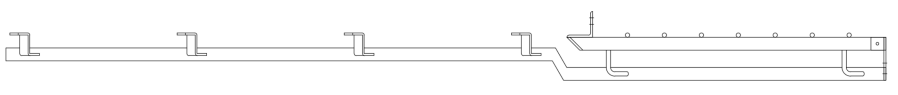
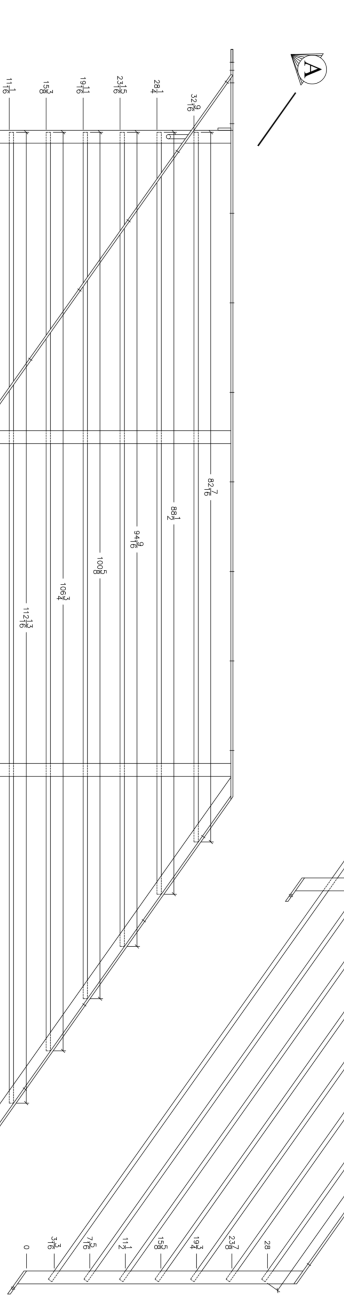

PICKETS

STEEL



SECTION B



SECTION E

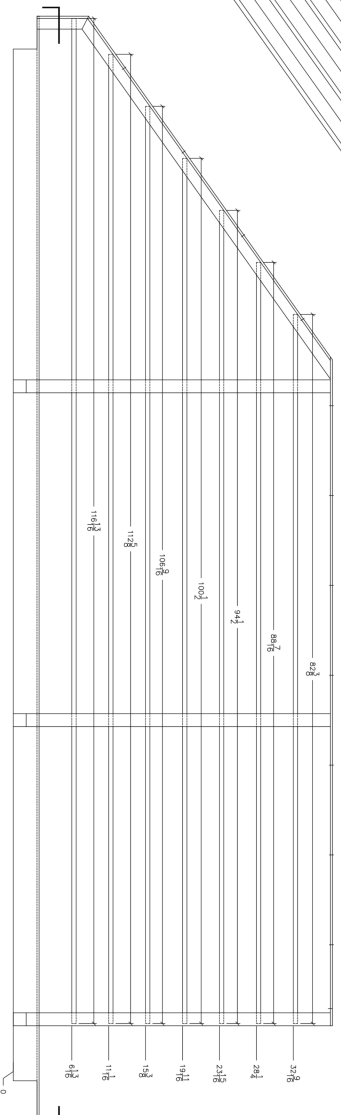
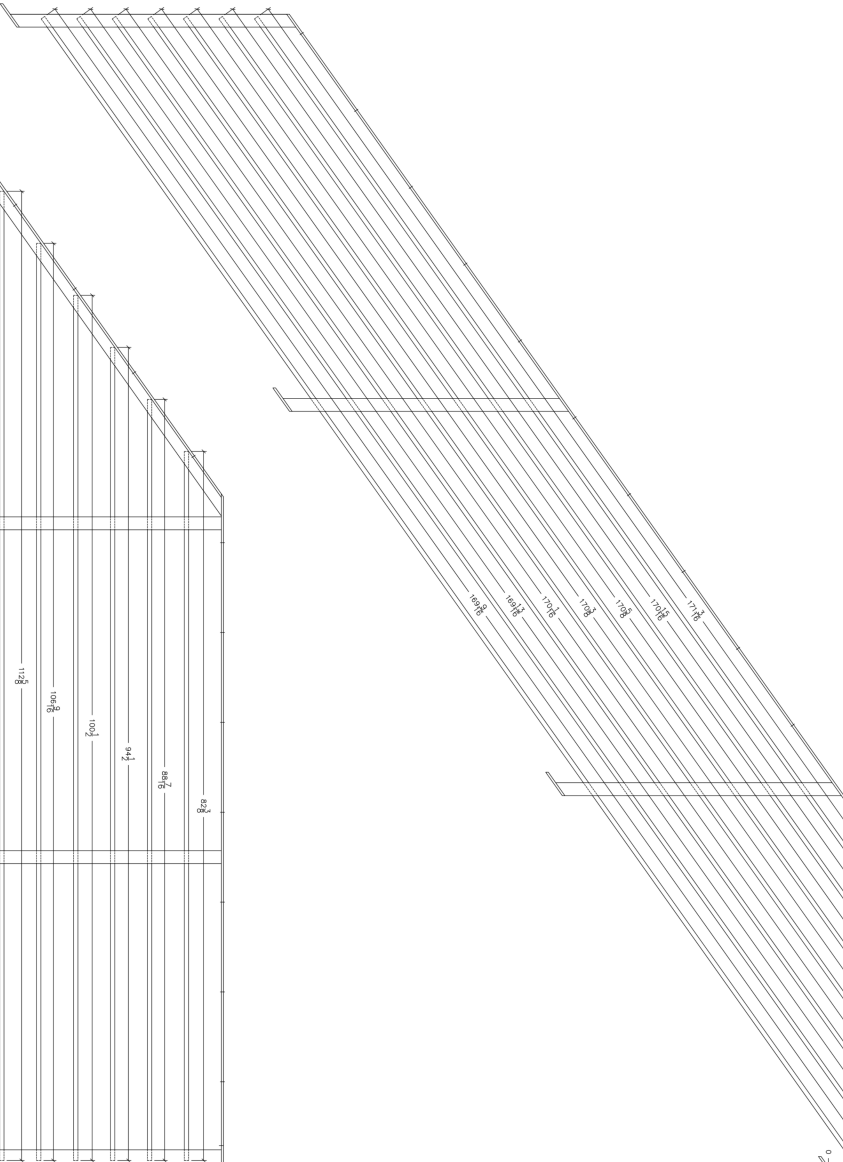
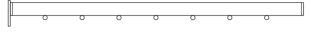
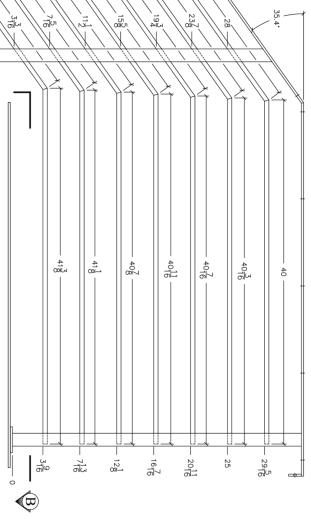

SECTION C

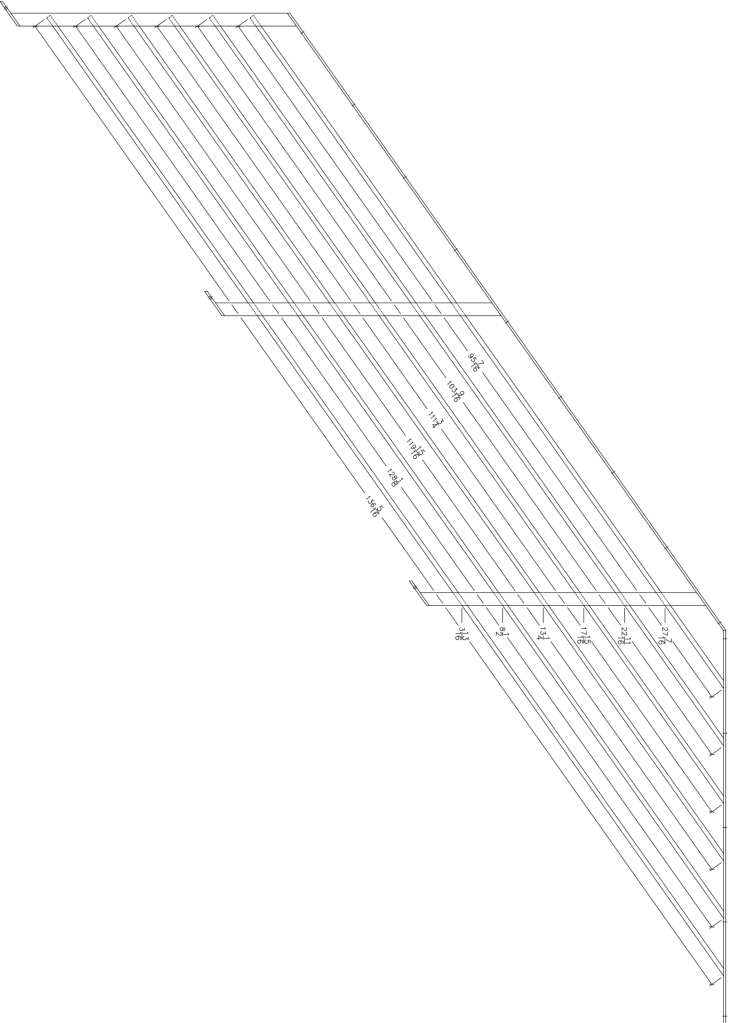
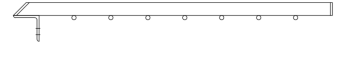

PICKETS

STEEL

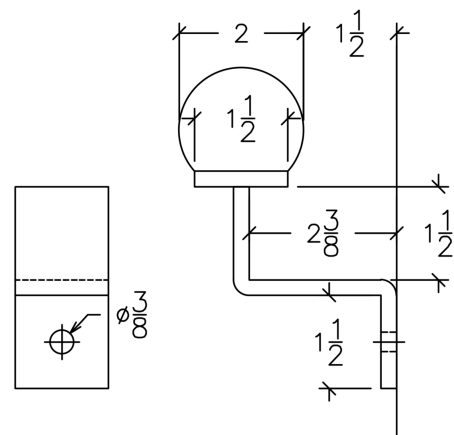

WALL BRACKETS
1 1/2 X 1/4 FLATBAR
QTY 4

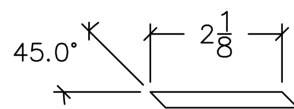

BOTTOM POST CAPS
1 1/2 X 1/4 FLATBAR
QTY 6

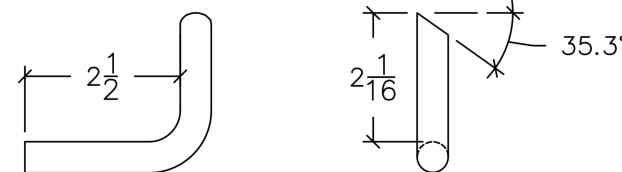

ROUNDBAR BRACKETS
1/2" ROUNDBAR
QTY 2

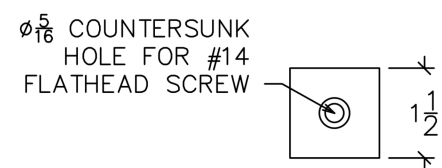

FLATBAR CLIP
(INTO WALL)
1 1/2 X 1/4 FLATBAR
QTY 2

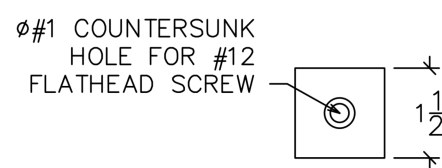

FLATBAR CLIP
(INTO POST)
1 1/2 X 1/4 FLATBAR
QTY 2

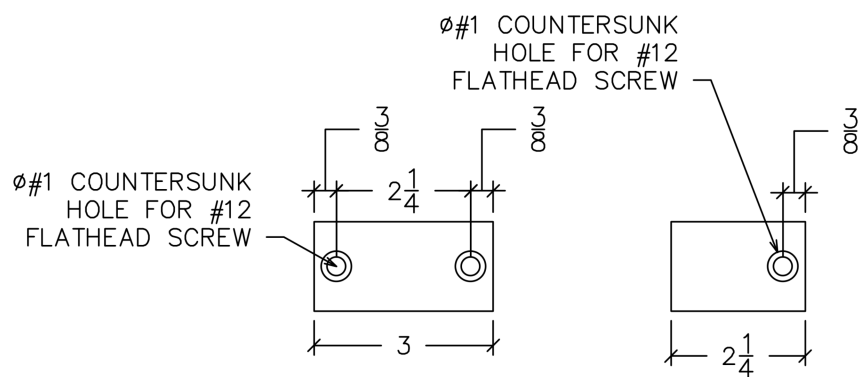

3" BASEPLATE
1 1/2 X 1/4 FLATBAR
QTY 4

2 1/4" BASEPLATE
1 1/2 X 1/4 FLATBAR
QTY 1

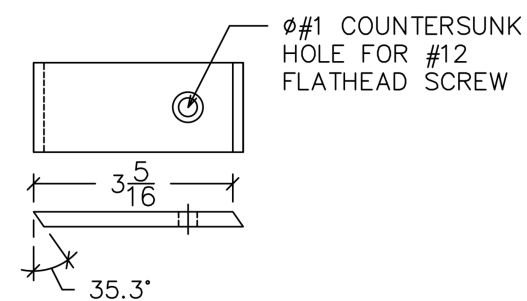

STRINGER BASEPLATE
1 1/2 X 1/4 FLATBAR
QTY 11

STEEL

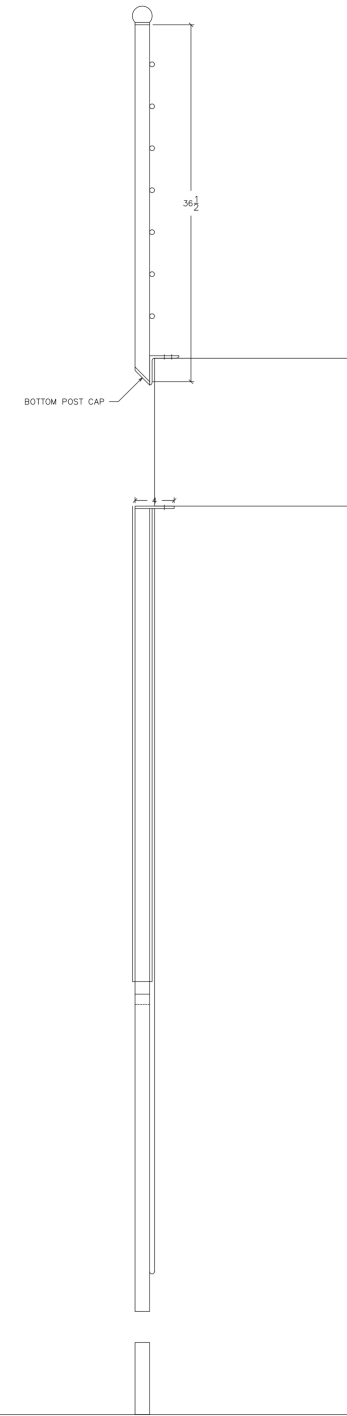
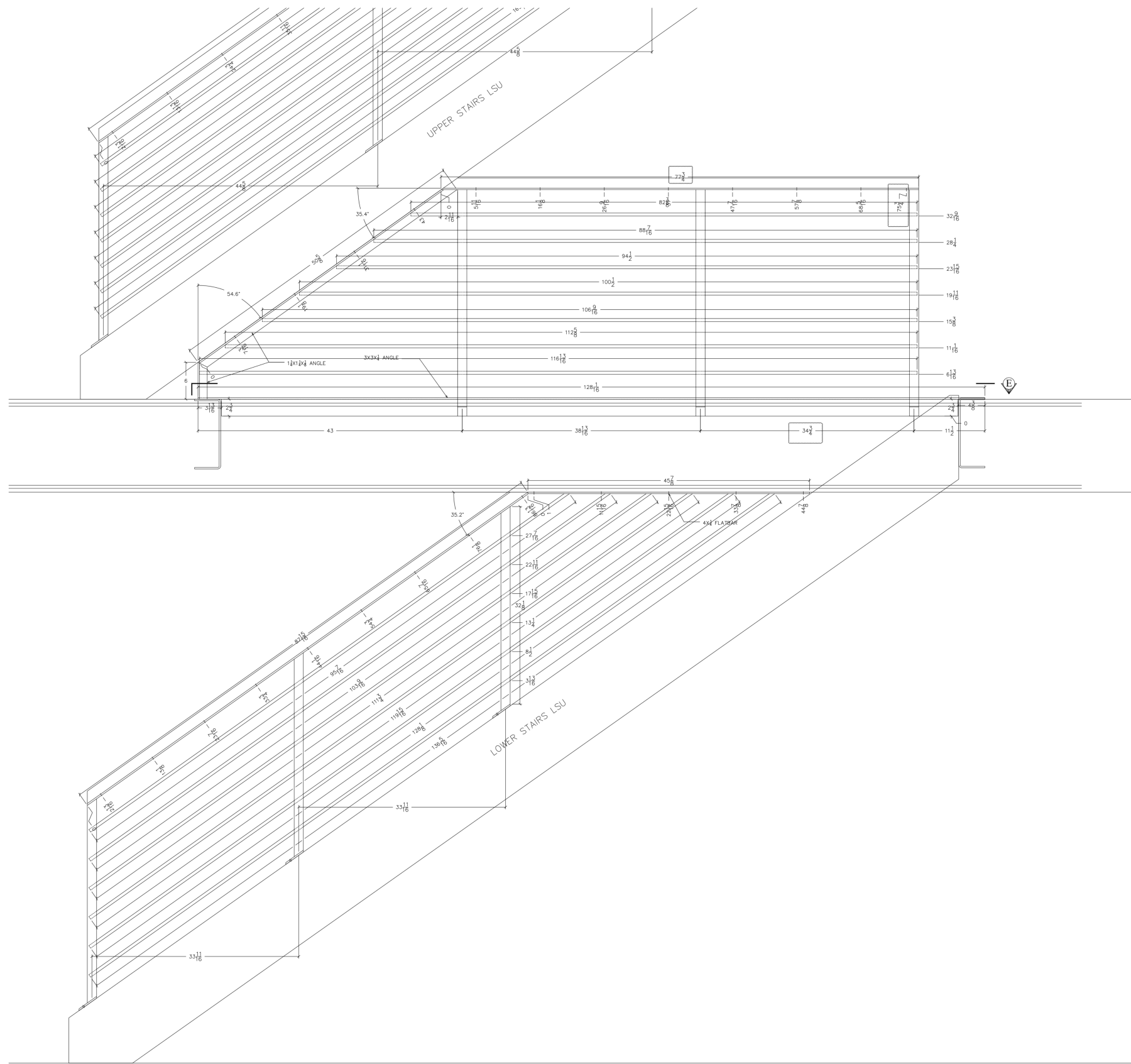

STEEL

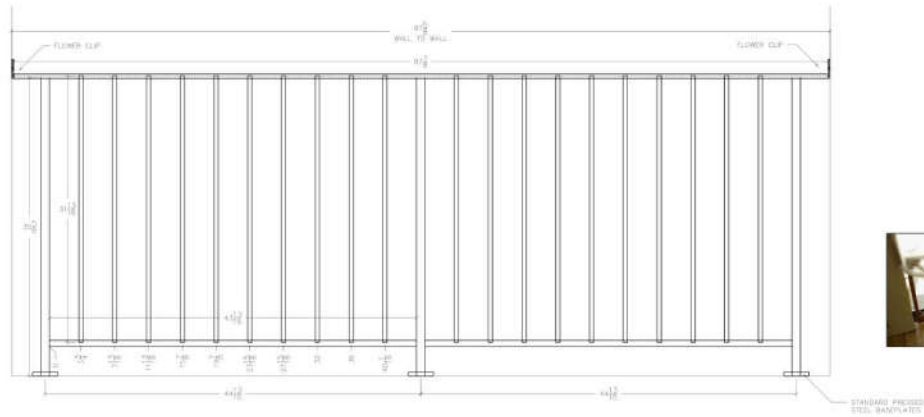

TOP FLOOR GUARDRAIL

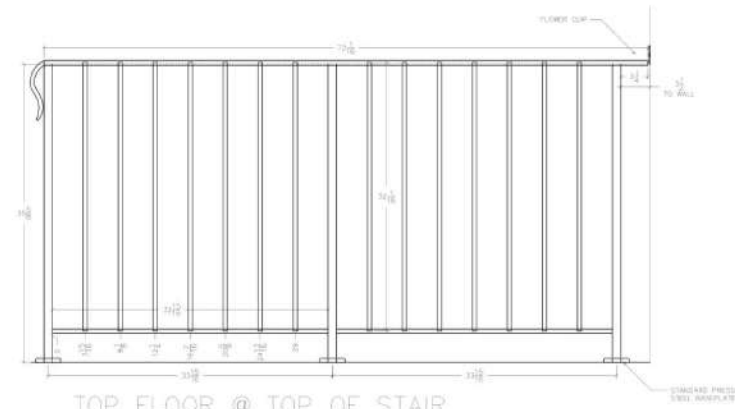

TOP FLOOR @ TOP OF STAIR

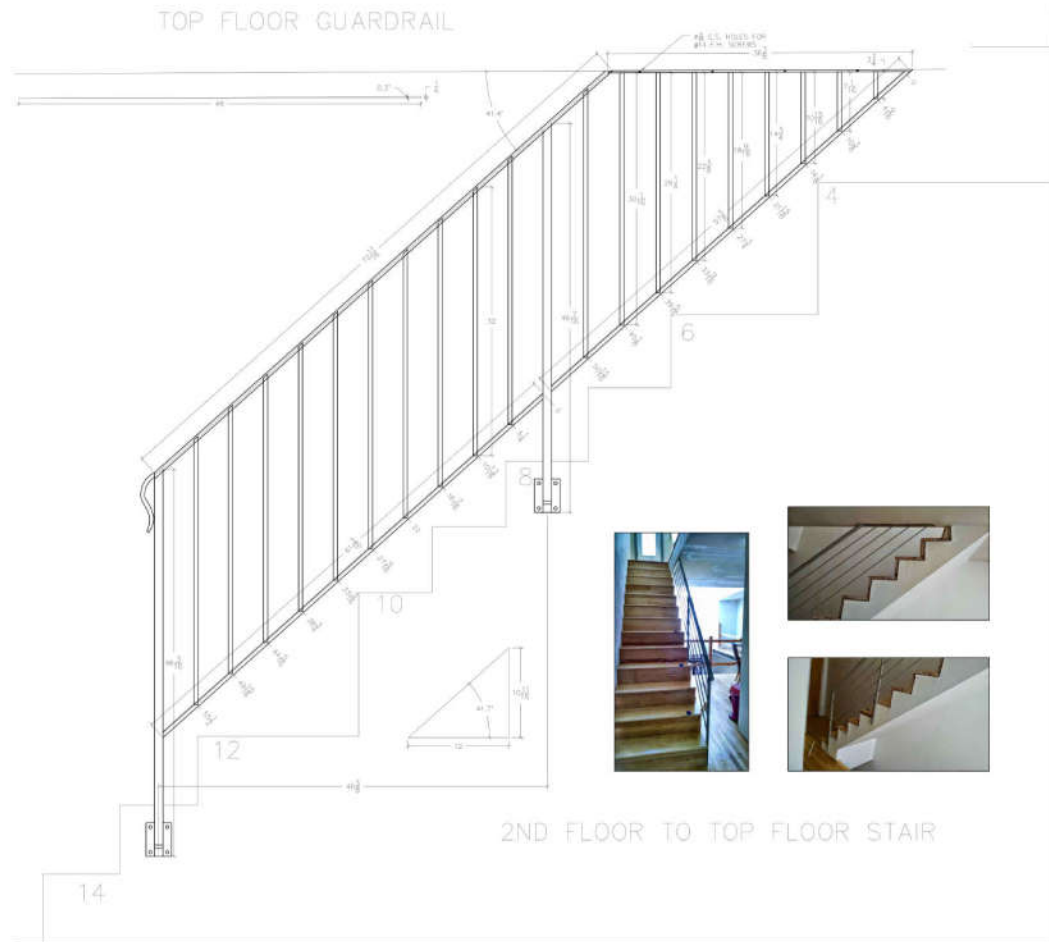

2ND FLOOR TO TOP FLOOR STAIR

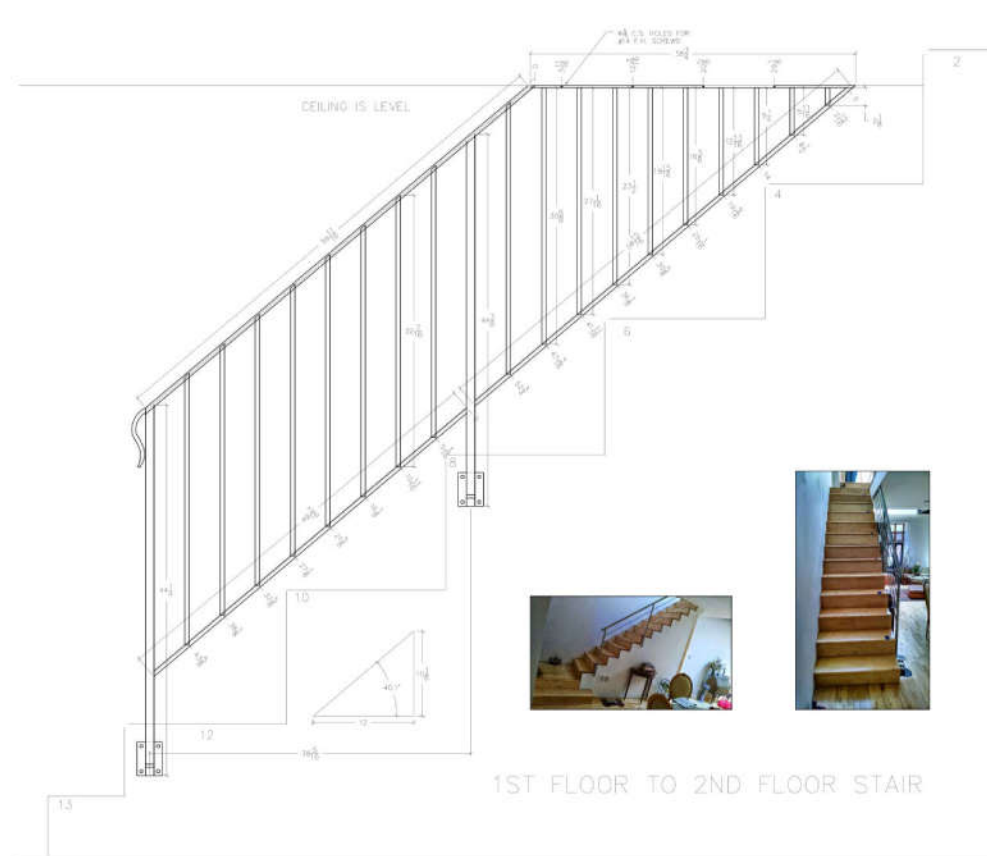
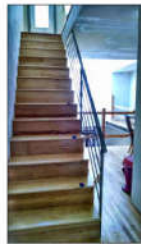

1ST FLOOR TO 2ND FLOOR STAIR

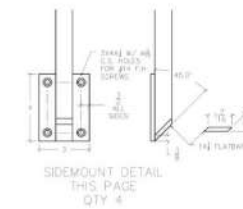

SIDEMOUNT DETAIL
THIS PAGE
QTY 4

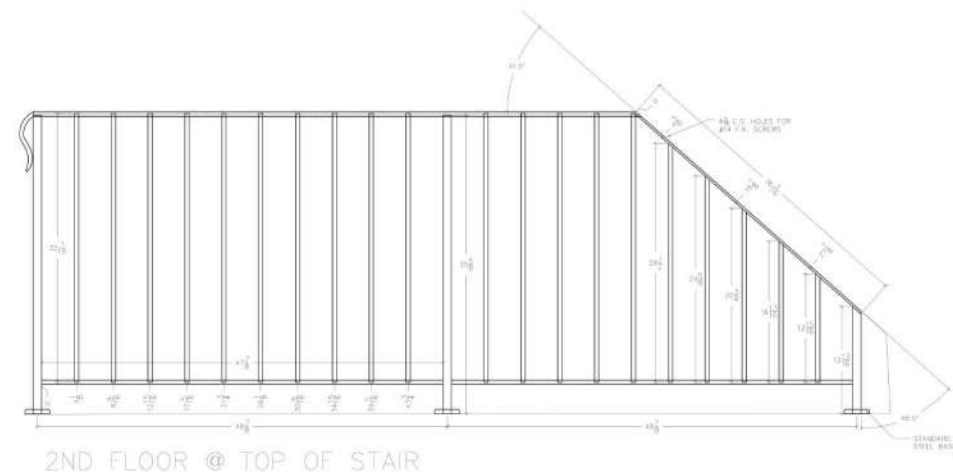

2ND FLOOR @ TOP OF STAIR

- MATERIALS:**
- TOP RAIL 1 1/2" MOLDING
 - BOTTOM RAIL 1X1/2X1/2 BAR CHANNEL
 - POSTS 1" SQ TUBE
 - PICKETS 1/2" SQ BAR
 - FLOOR MOUNT BASEPLATES PRESSED STEEL (QTY 13)
 - SIDE MOUNT BASEPLATES 3X1/2 FLATBAR
 - SIDE MOUNT POST END CAPS 1X1/2 FLATBAR
 - CEILING MOUNT PLATES 1X1/2 FLATBAR
 - HARDWARE:**
 - #14 F.H. SCREWS QTY 99
 - 5/8" HEX HEAD LAGS QTY 5
 - 3/8" TEK SCREWS QTY 4

STAIR & LANDING RAILS

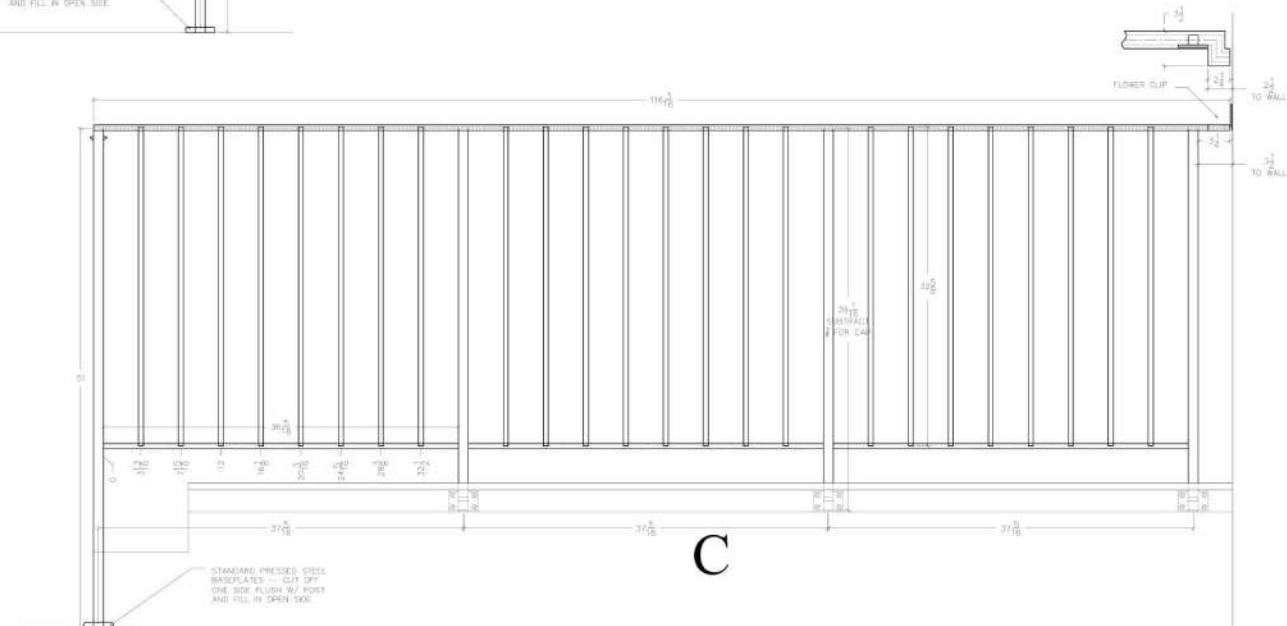
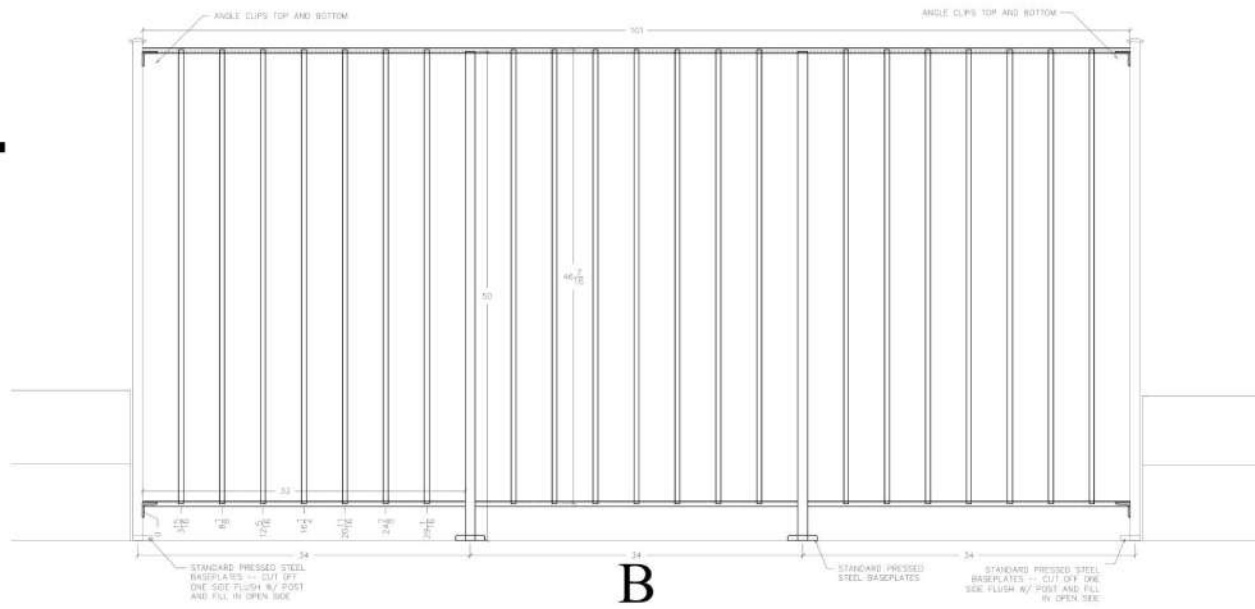
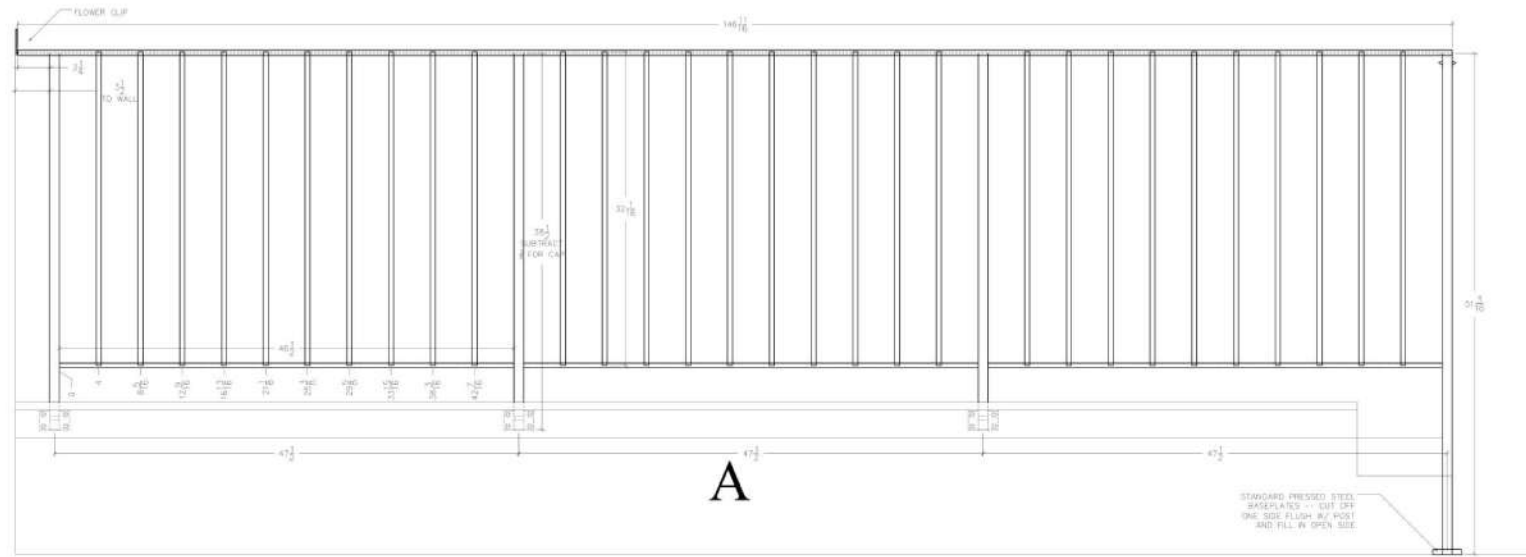
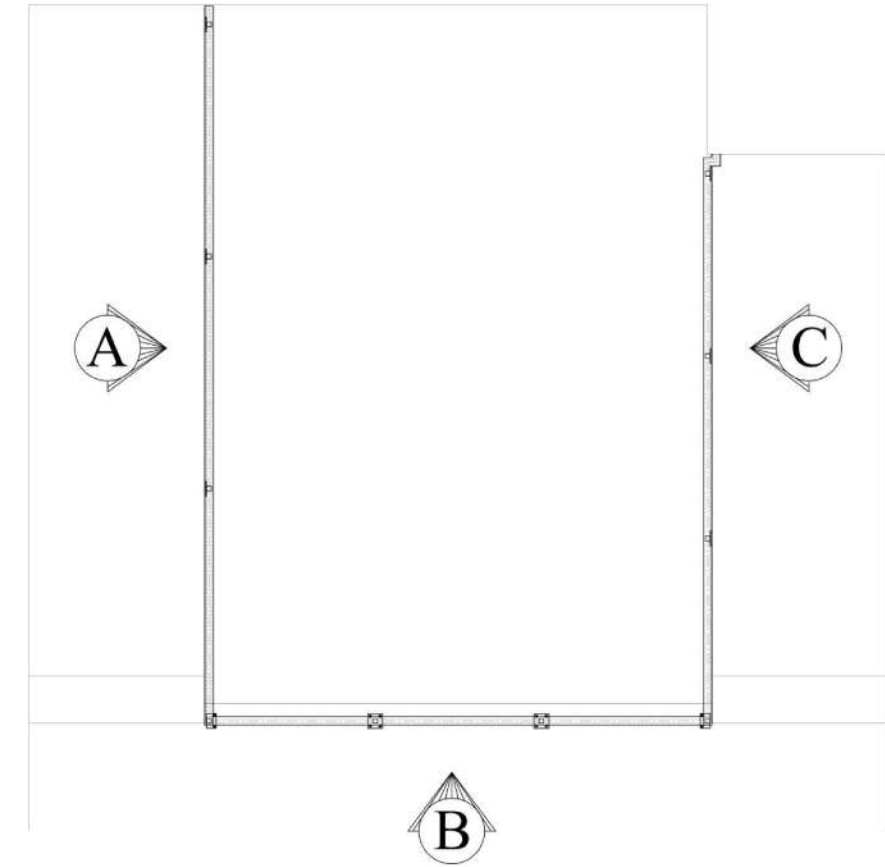
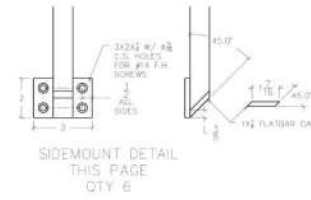
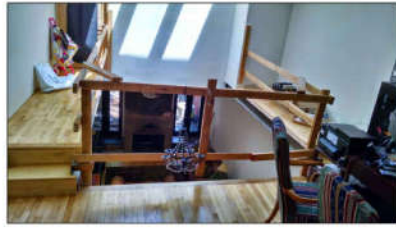

2ND FLOOR LOFT RAILS

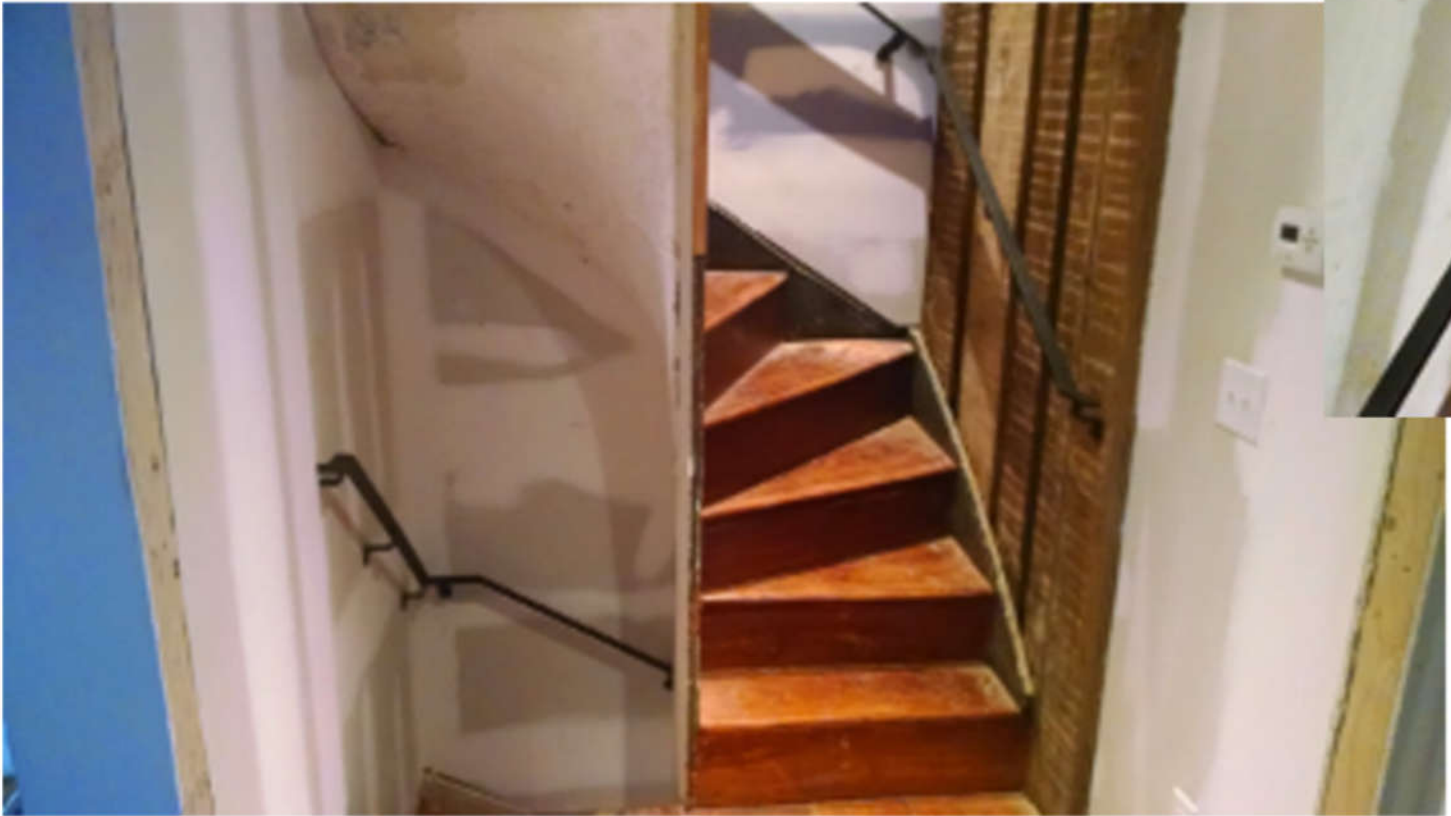

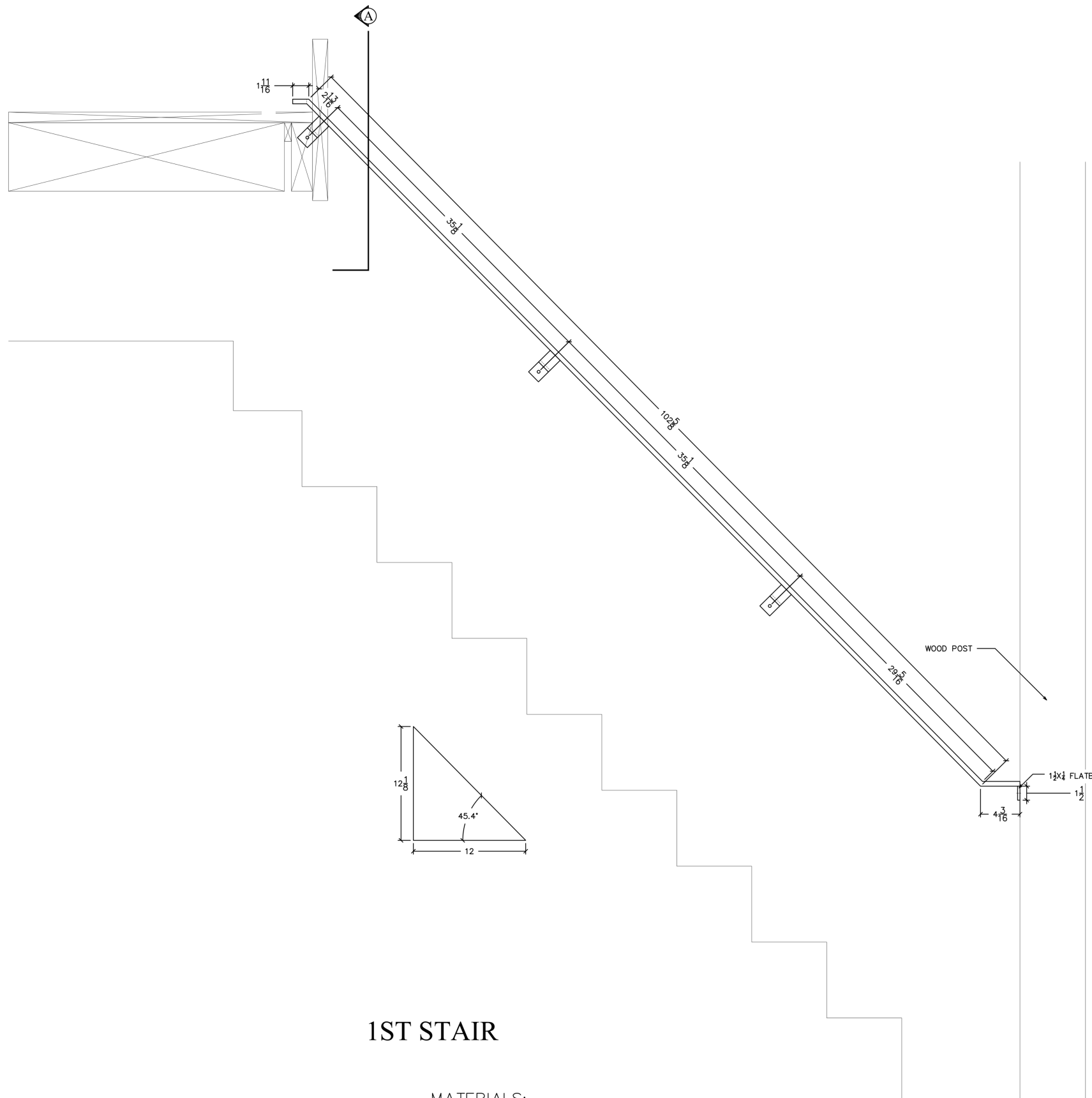

1ST STAIR

- MATERIALS:
 TOP RAIL 1 1/2 X 1/2 FLATBAR
 BRACKETS 1 1/2 X 1/4 FLATBAR
 FINISH: (THIS PAGE ONLY)
 ACID PATINA W/ CLEAR
 PERMALAC

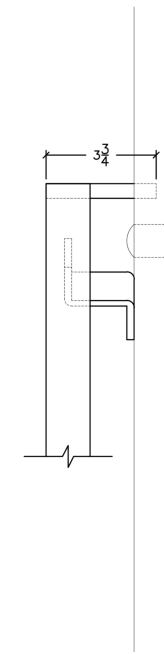

SECTION A

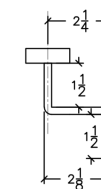

- WALL MOUNT BRACKET
 1 1/2 X 1/4 FLATBAR
 C.S. HOLE FOR #14
 FLATHEAD SCREW
 QTY 19

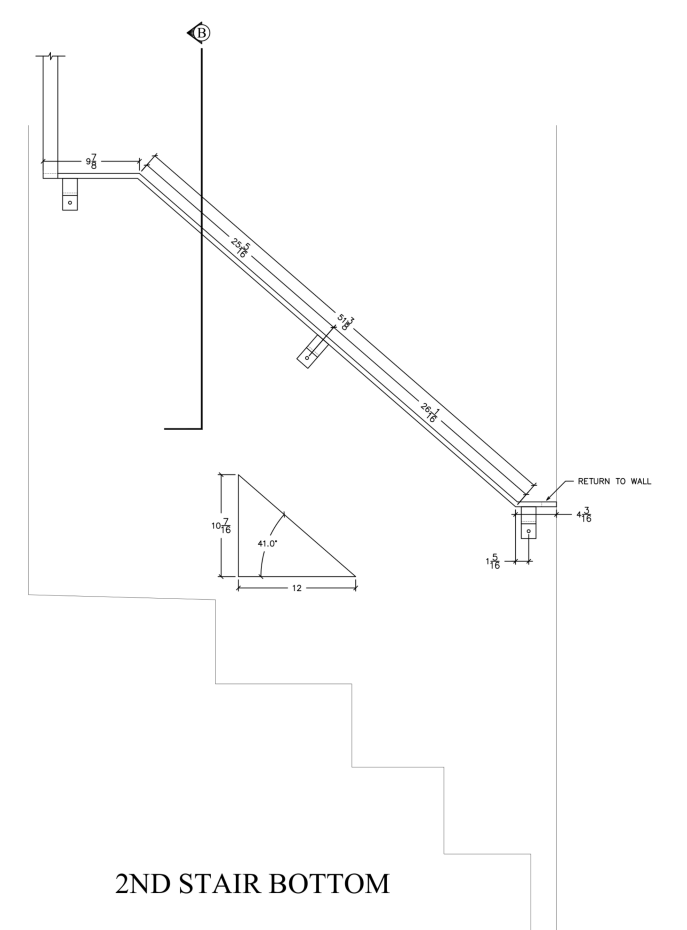
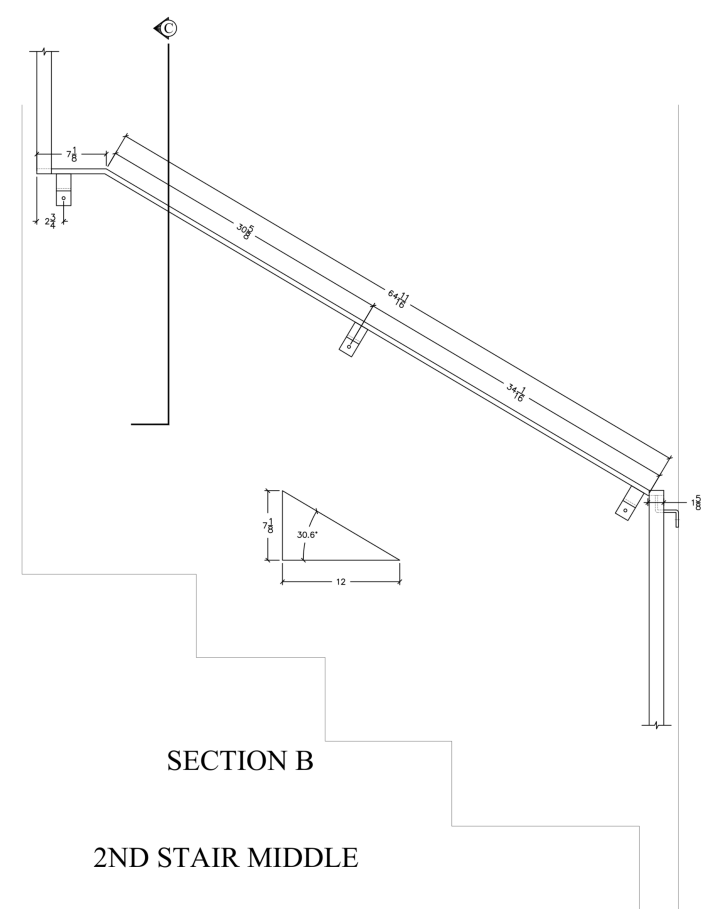
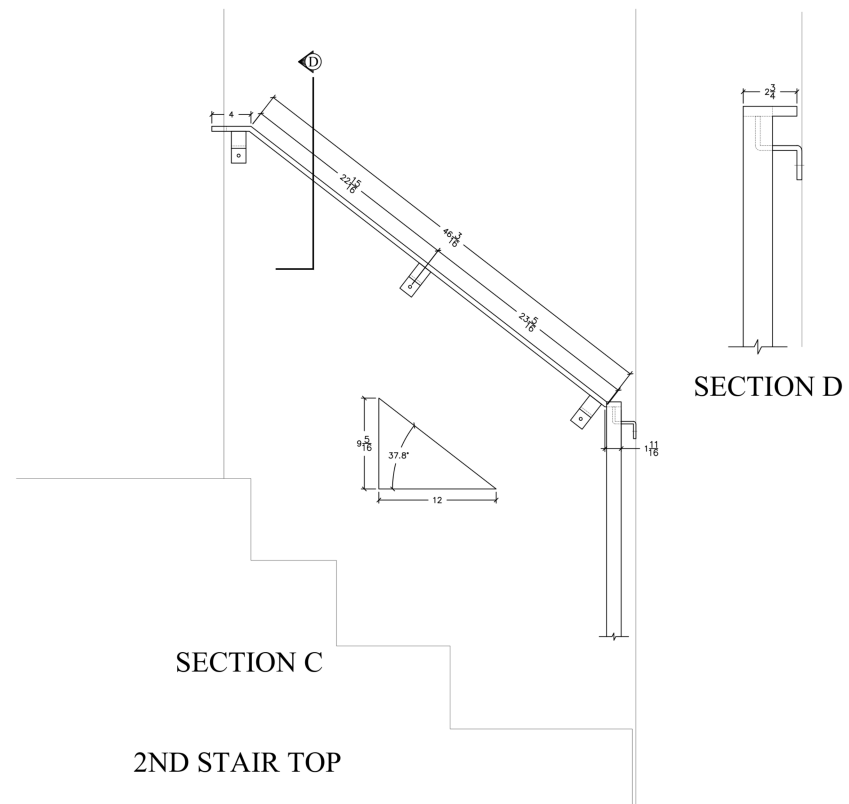

- MATERIALS:
 TOP RAIL 1 1/2 X 1/2 FLATBAR
 BRACKETS 1 1/2 X 1/4 FLATBAR
 FINISH: (THIS PAGE ONLY)
 PAINT FLAT BLACK

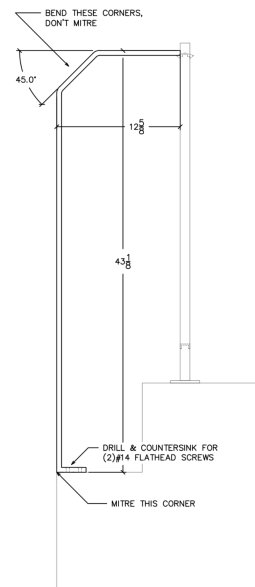

TOP STAIR TOP LEFT SIDE (UP)

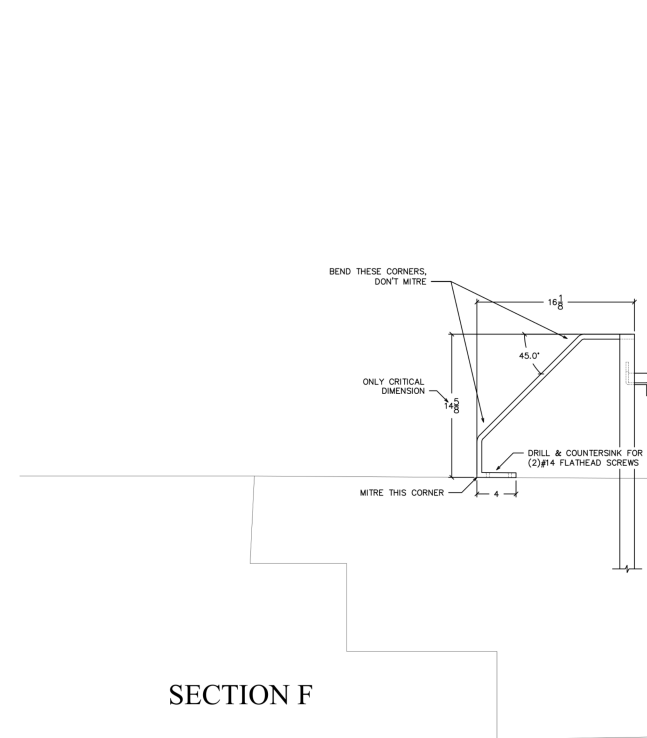

SECTION F
TOP STAIR TOP RIGHT SIDE (UP)

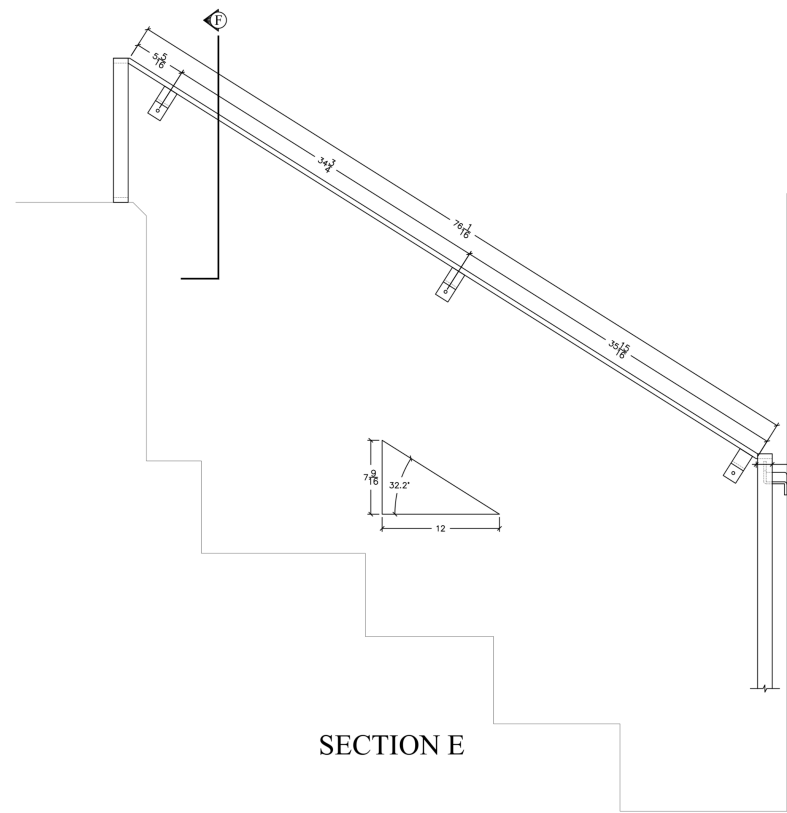

SECTION E
TOP STAIR MIDDLE

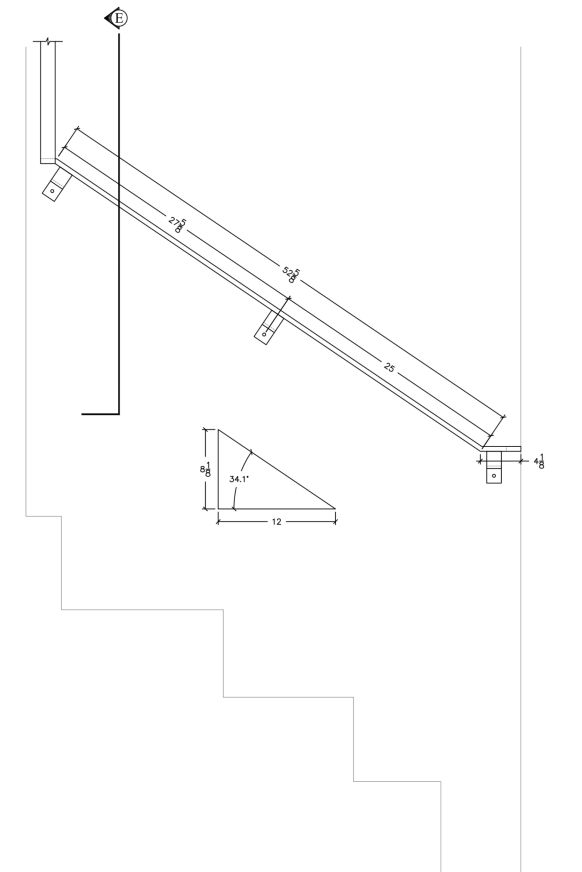

TOP STAIR BOTTOM

- MATERIALS:
 TOP RAIL 1 1/2 x 1/2 FLATBAR
 BRACKETS 1 1/2 x 1/4 FLATBAR
 FINISH: (THIS PAGE ONLY)
 PAINT FLAT BLACK

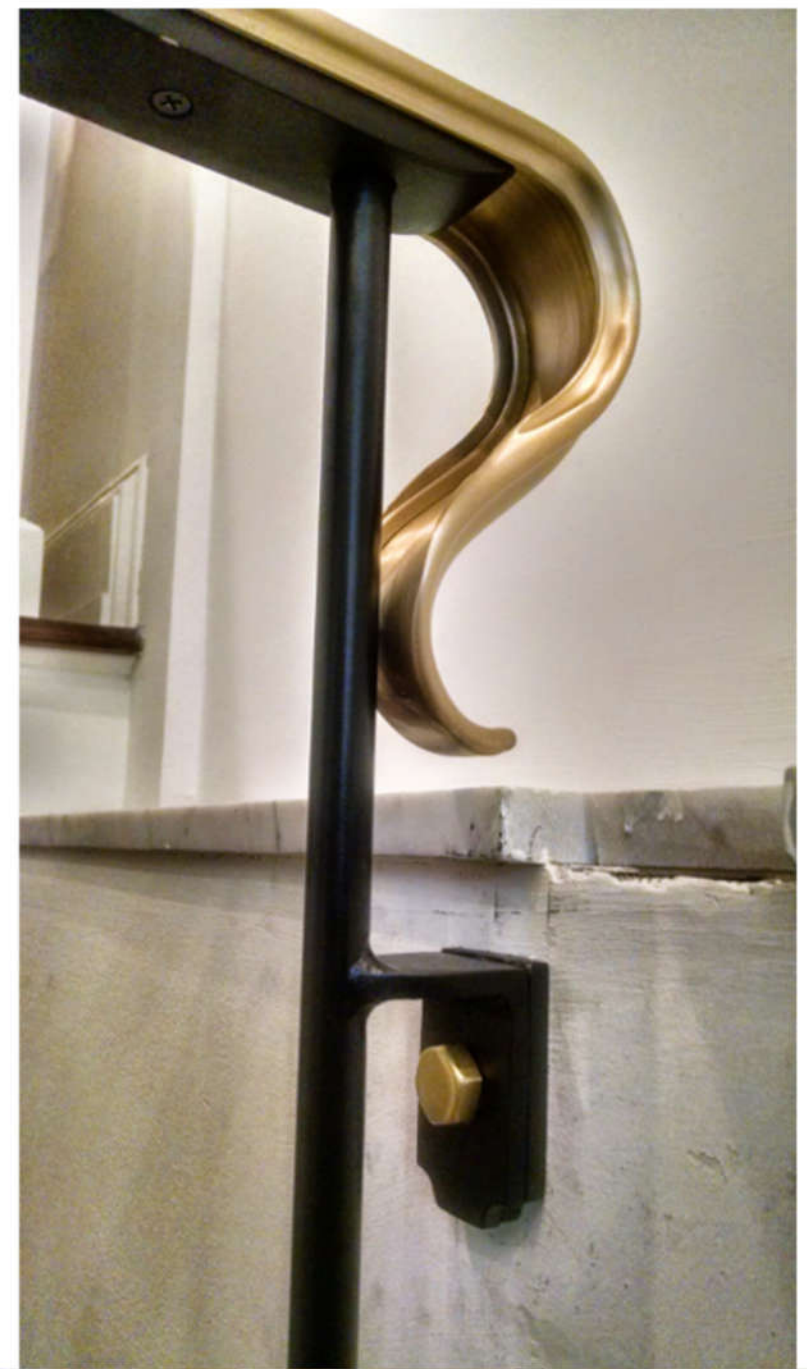
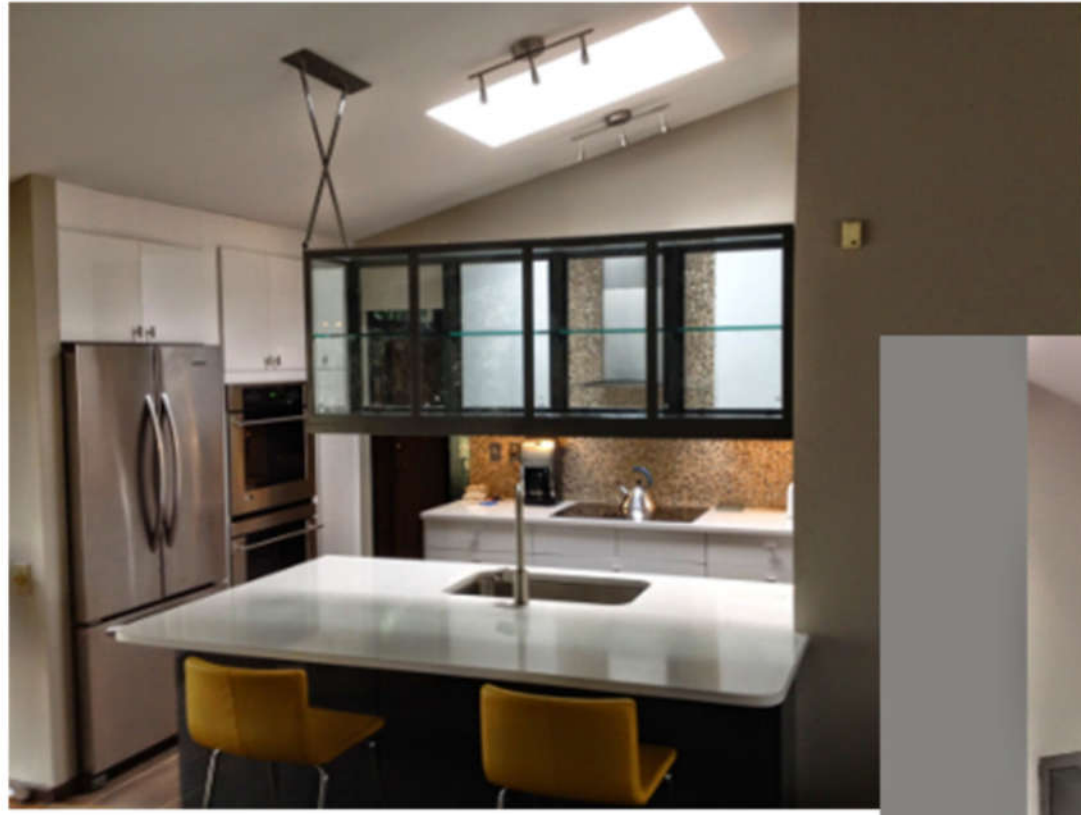

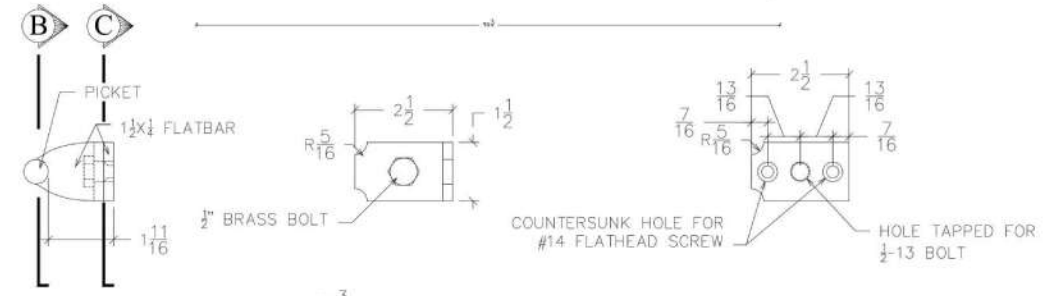
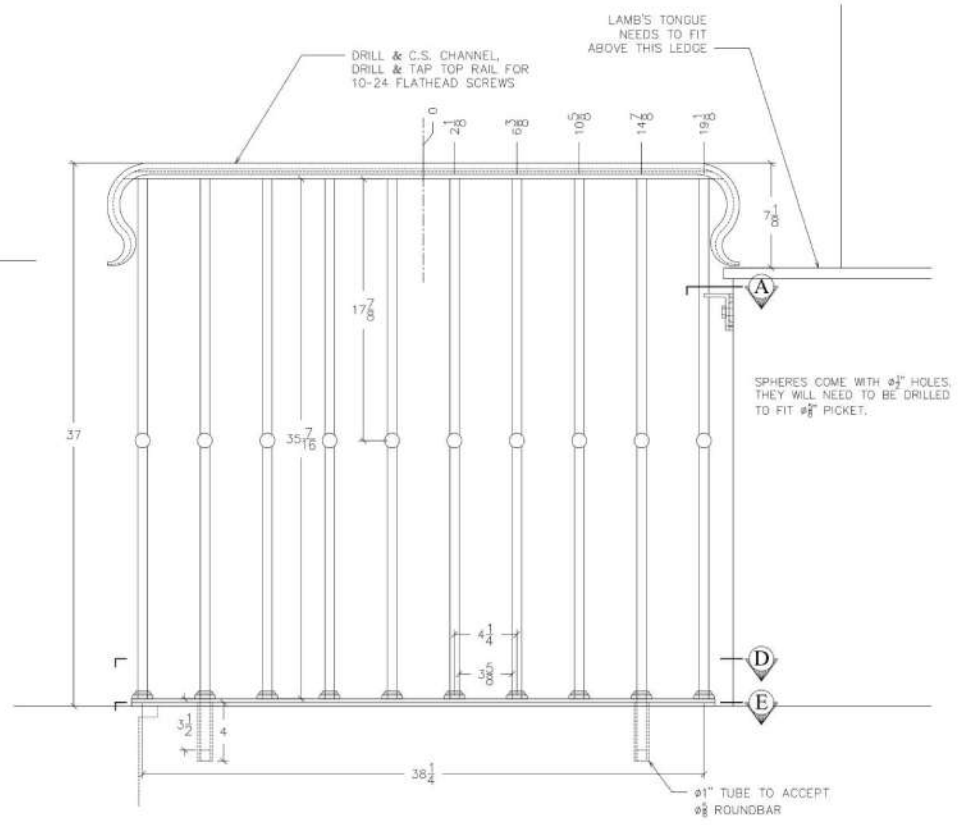
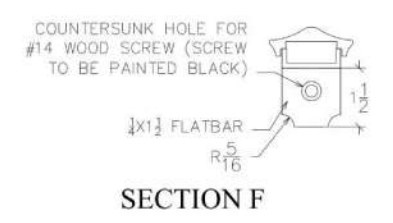
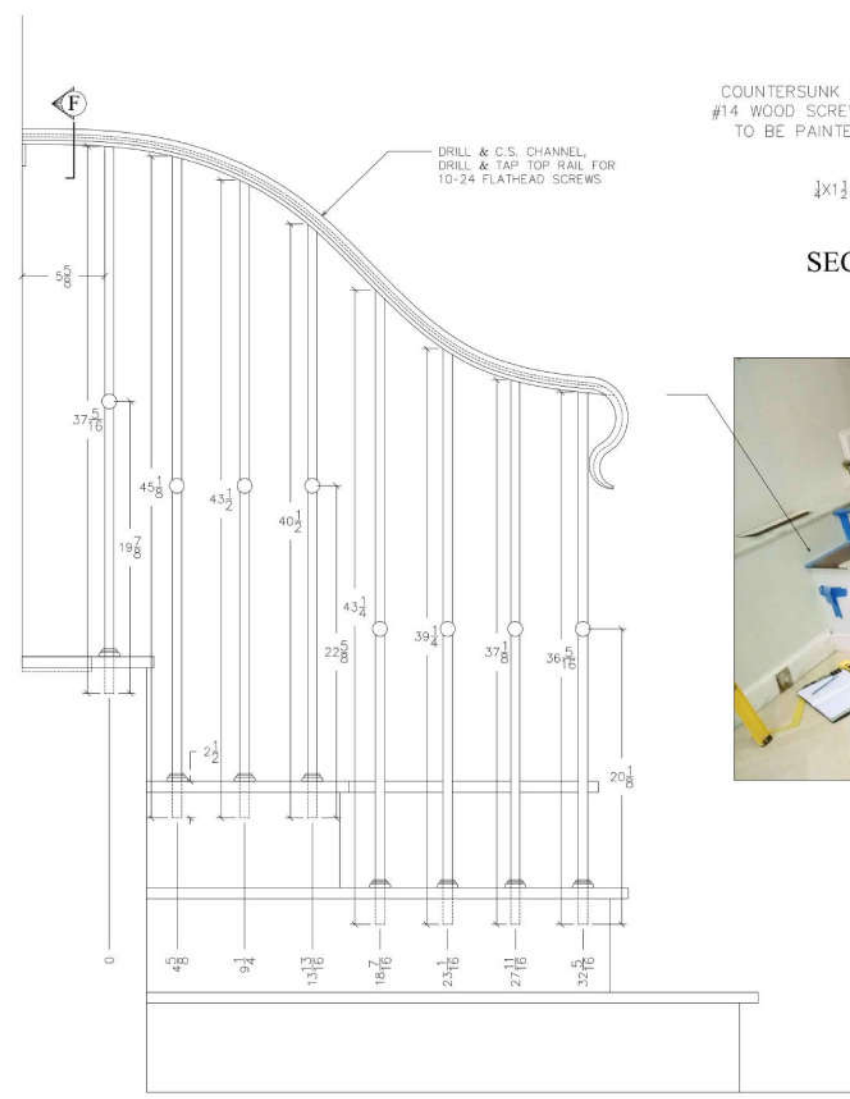

- MATERIALS:**
- TOP RAIL 2 1/4 BRASS MOLDING
 - TOP CHANNEL 1 1/2 x 1/2 x 1/8 STEEL BAR CHANNEL
 - PICKETS 5/8 1018 COLD ROLLED STEEL
 - SPHERES 1 9/16" PIERCED (DRILL TO FIT 5/8" PICKET)
 - BRACKETS MADE FROM 1/2 x 1 1/2 STEEL FLATBAR
 - FLOOR PLATE 1/2 x 1 1/2 STEEL FLATBAR W/ 1" STEEL TUBES
 - SHOES CAST STEEL QTY 18

- HARDWARE:**
- 1/2-13x1" BRASS BOLT QTY 1
 - #14x1" FLATHEAD SCREWS QTY 9
 - #14x2" FLATHEAD SCREWS QTY 9
 - 1/4-20 HOLLOW WALL ANCHORS QTY 3
 - 10-24 FLATHEAD SCREWS QTY 9

- OTHER:**
- DRILL FOR 5/8" PICKETS INTO WOOD FLOOR
 - DRILL FOR 5/8" PICKET INTO MARBLE LEDGE
 - DRILL FOR 1" TUBES INTO WOOD FLOOR
 - EPOXY FOR PICKETS INTO STEPS

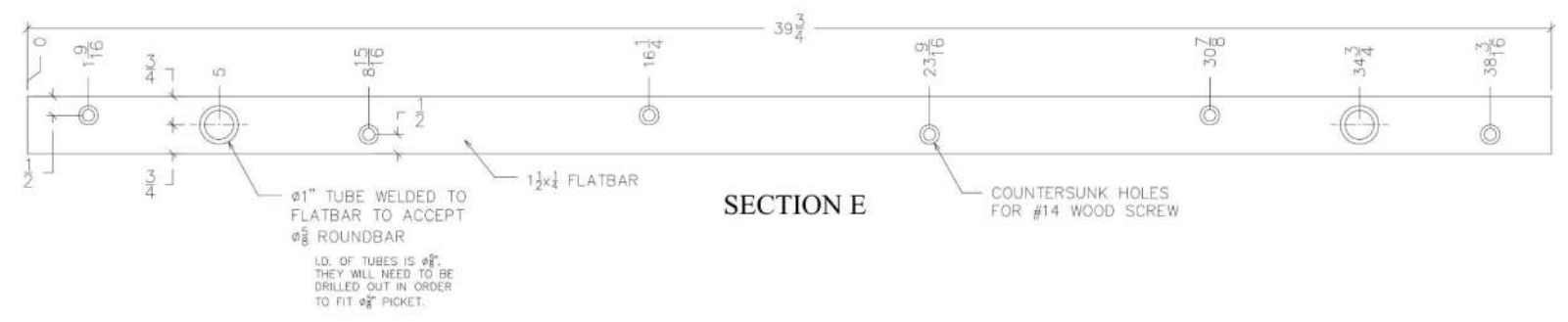
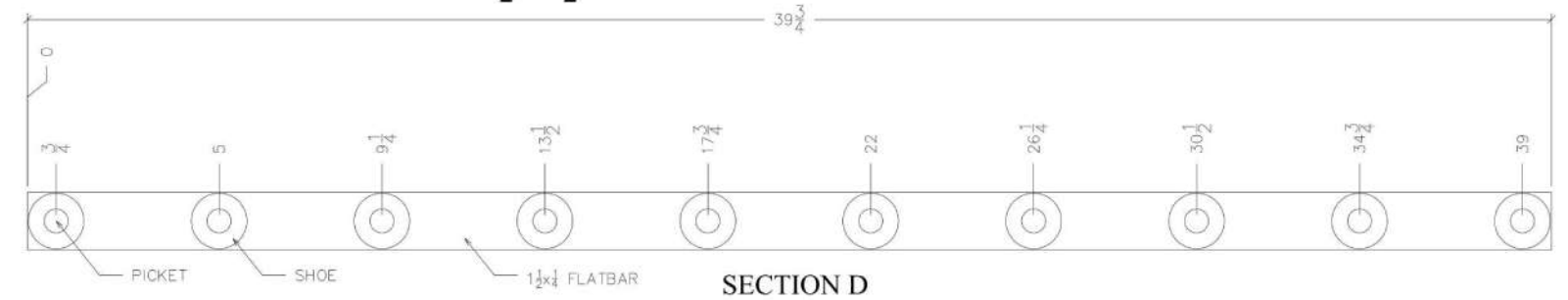

STEEL W/ BRASS TOP

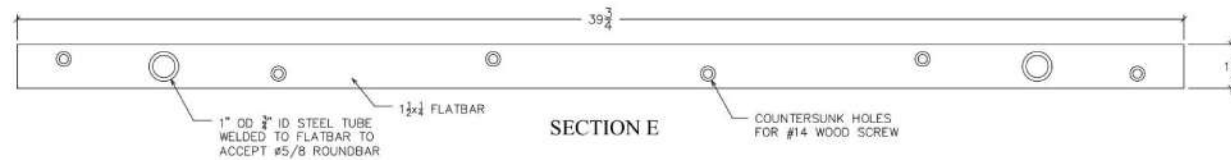
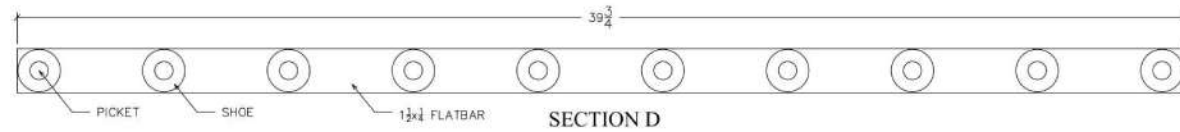
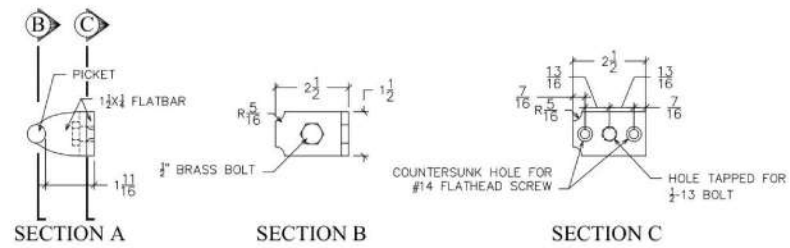
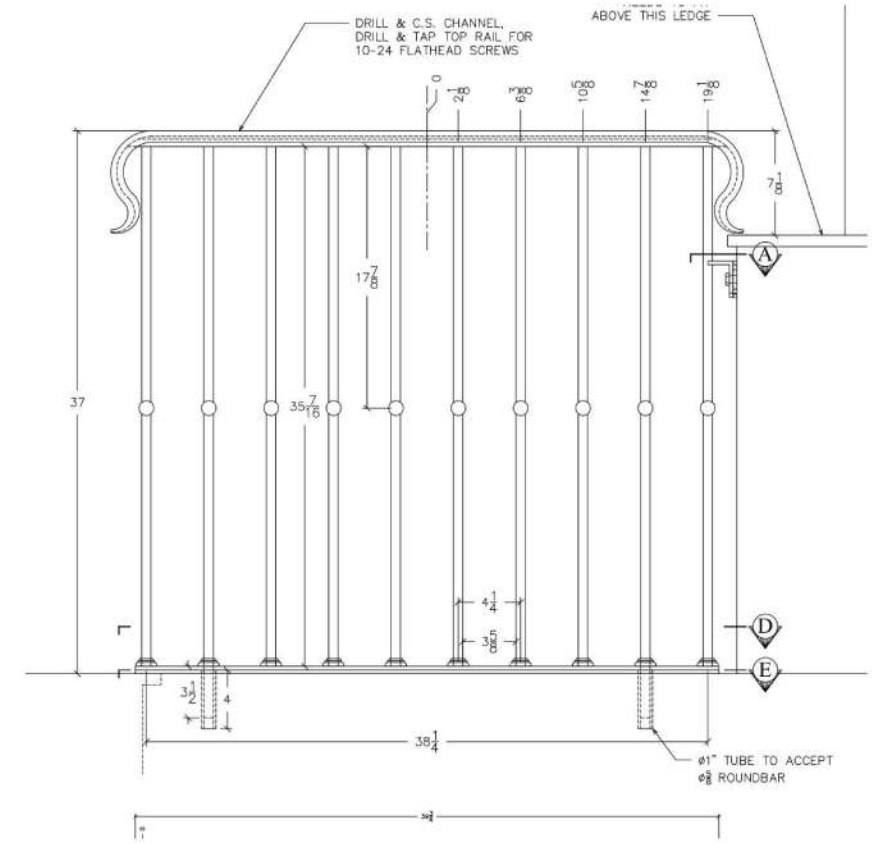
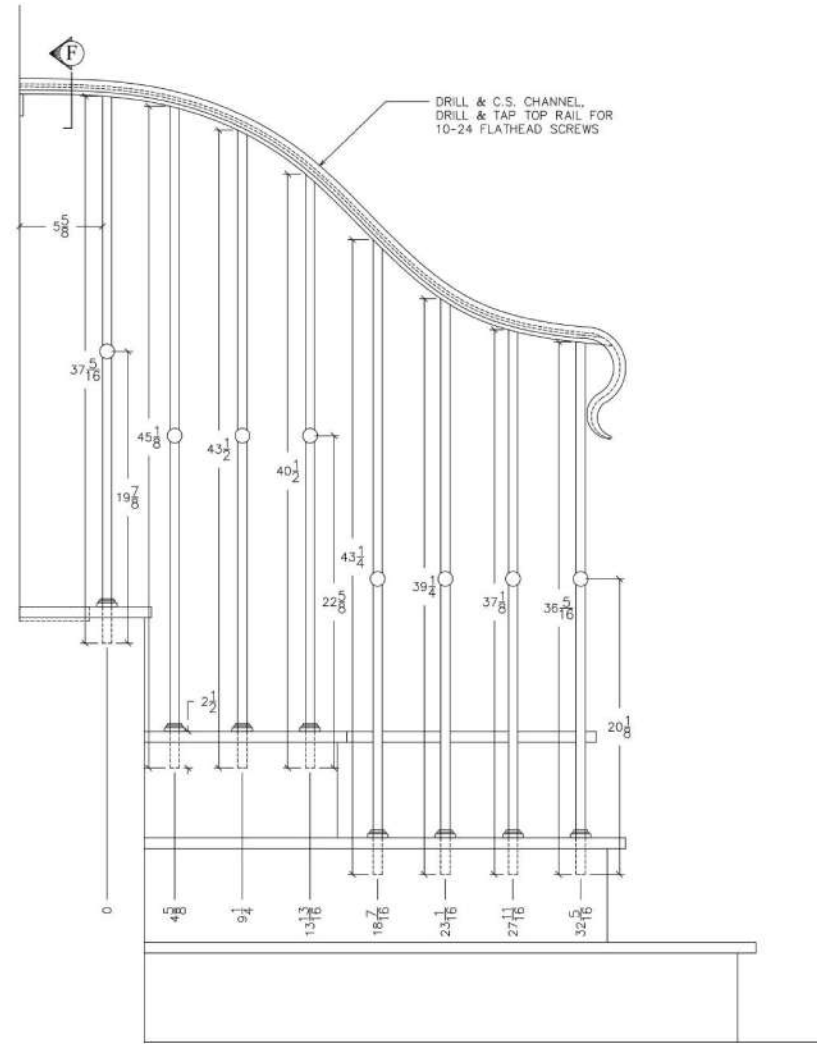
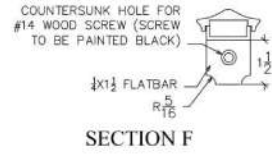

DRAWN: EY.	BenFab, Inc. 13 S. Highland Ave Lansdowne, PA 19050 Phone: 610-626-9100 Fax: 610-626-9200 www.benfabrailings.com	JMA SHELLER INTERIOR
DATE: 8/15/14		
REV: 2		

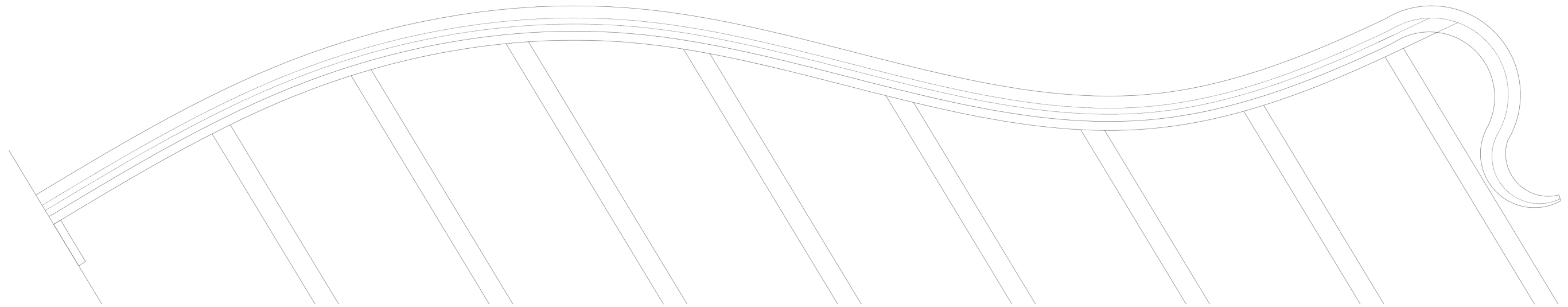

STEEL W/ BRASS TOP

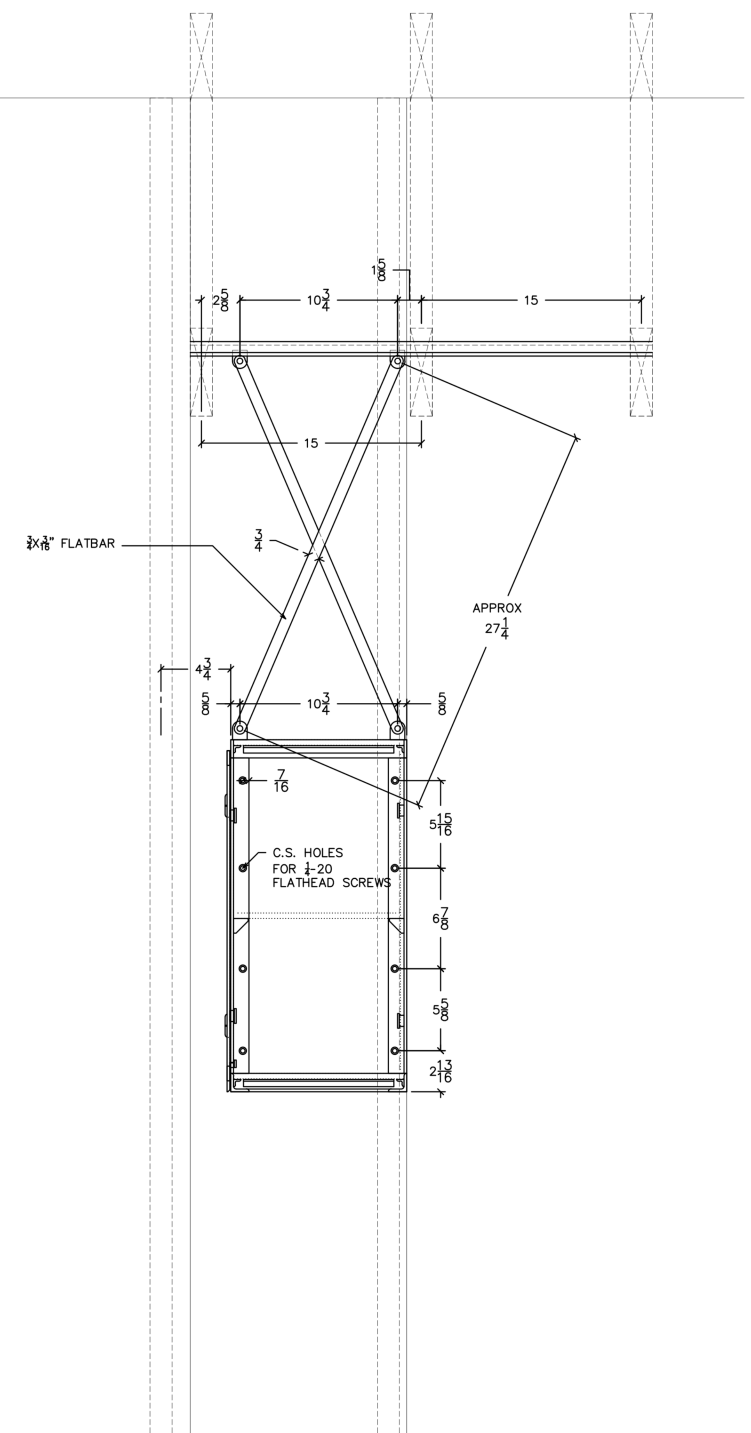
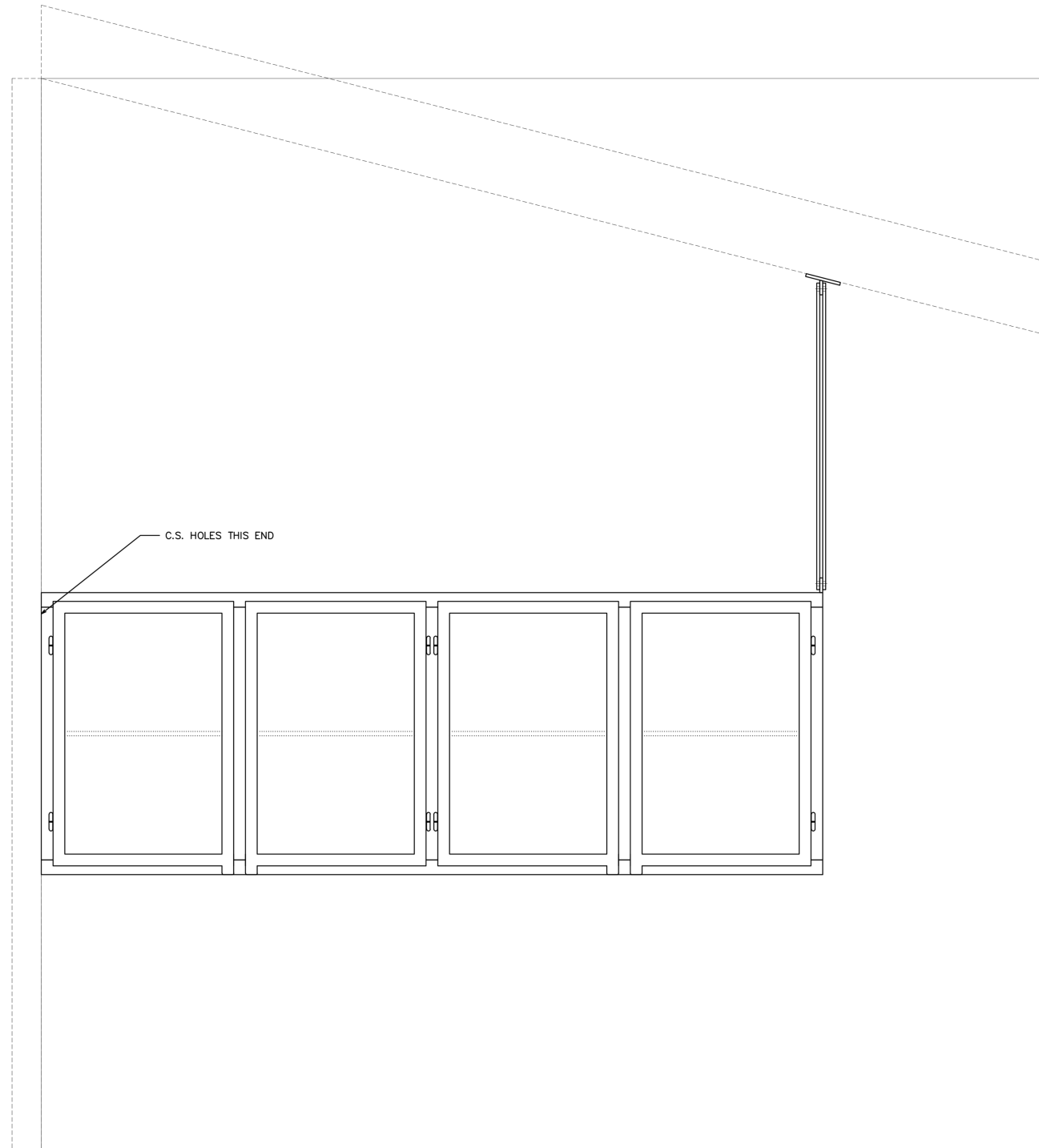

STEEL

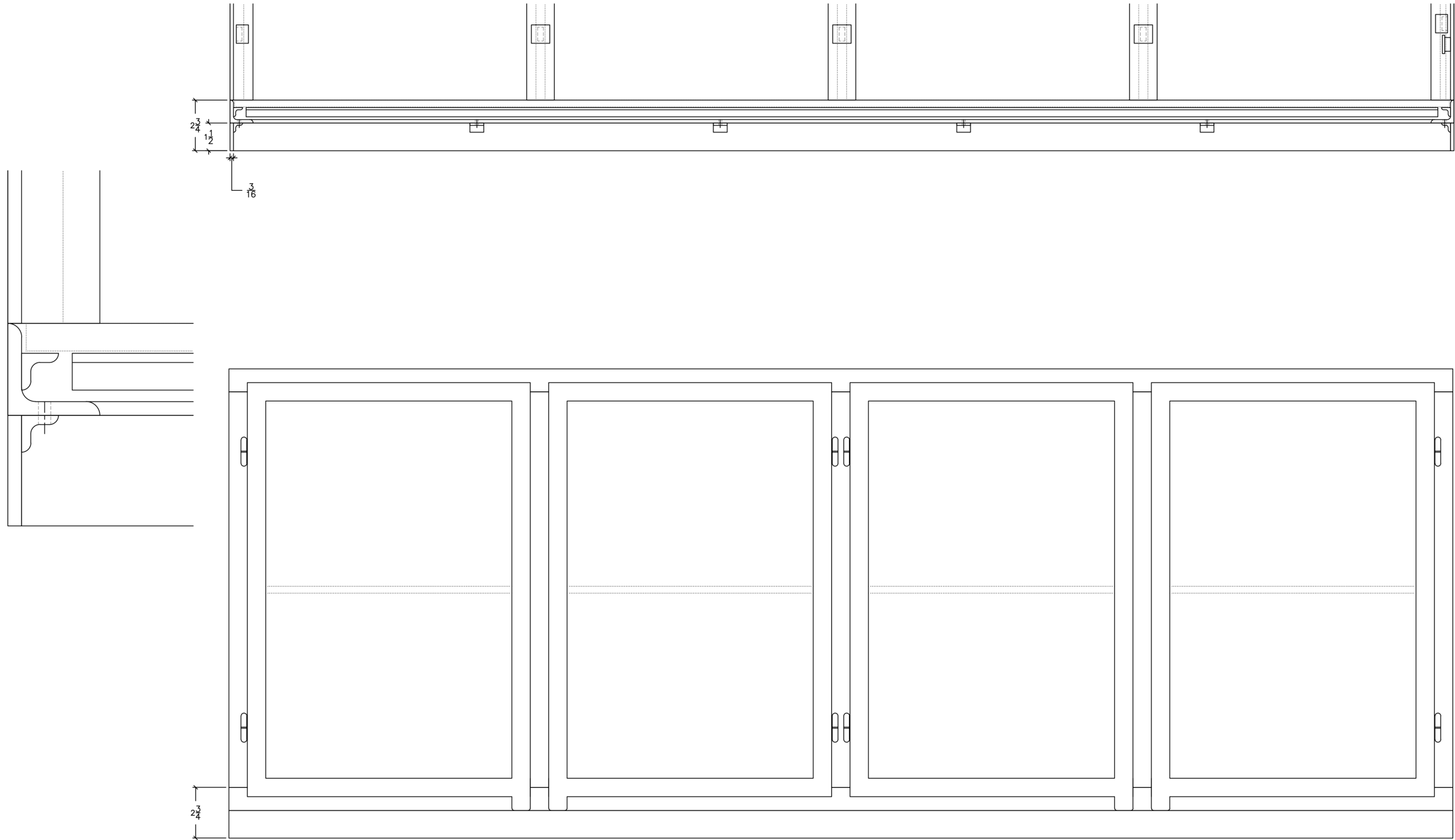

STEEL

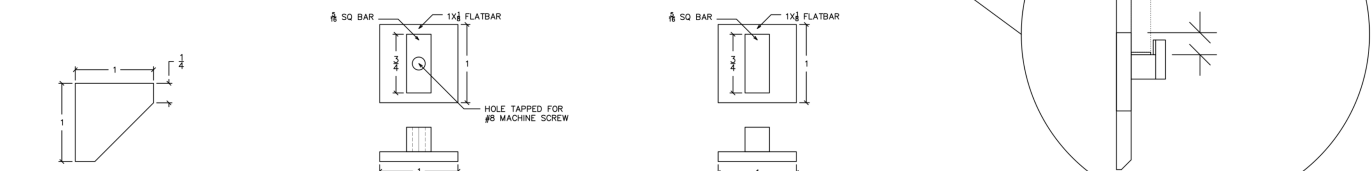
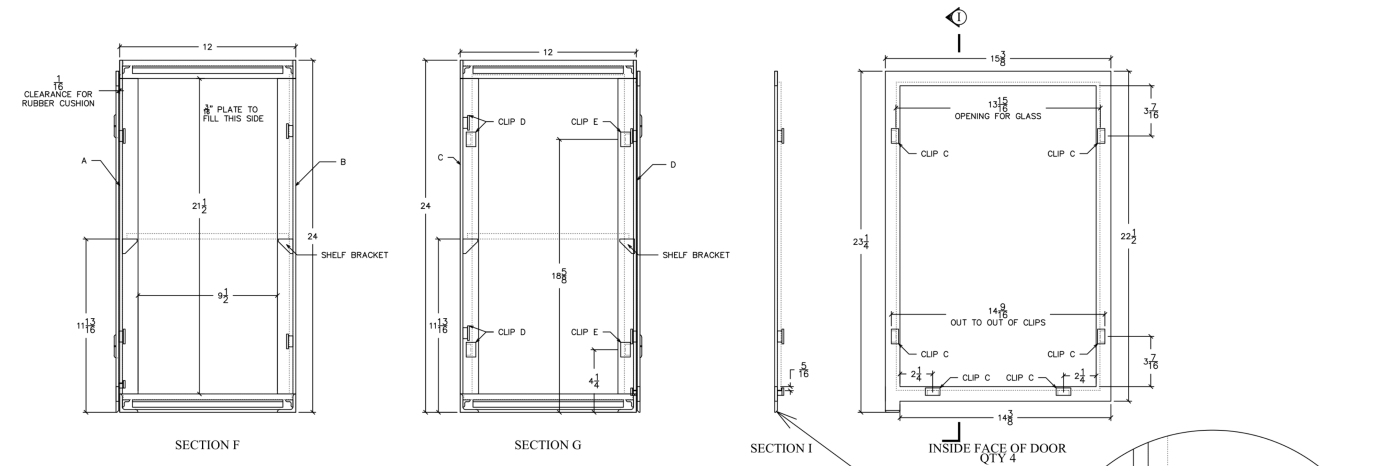
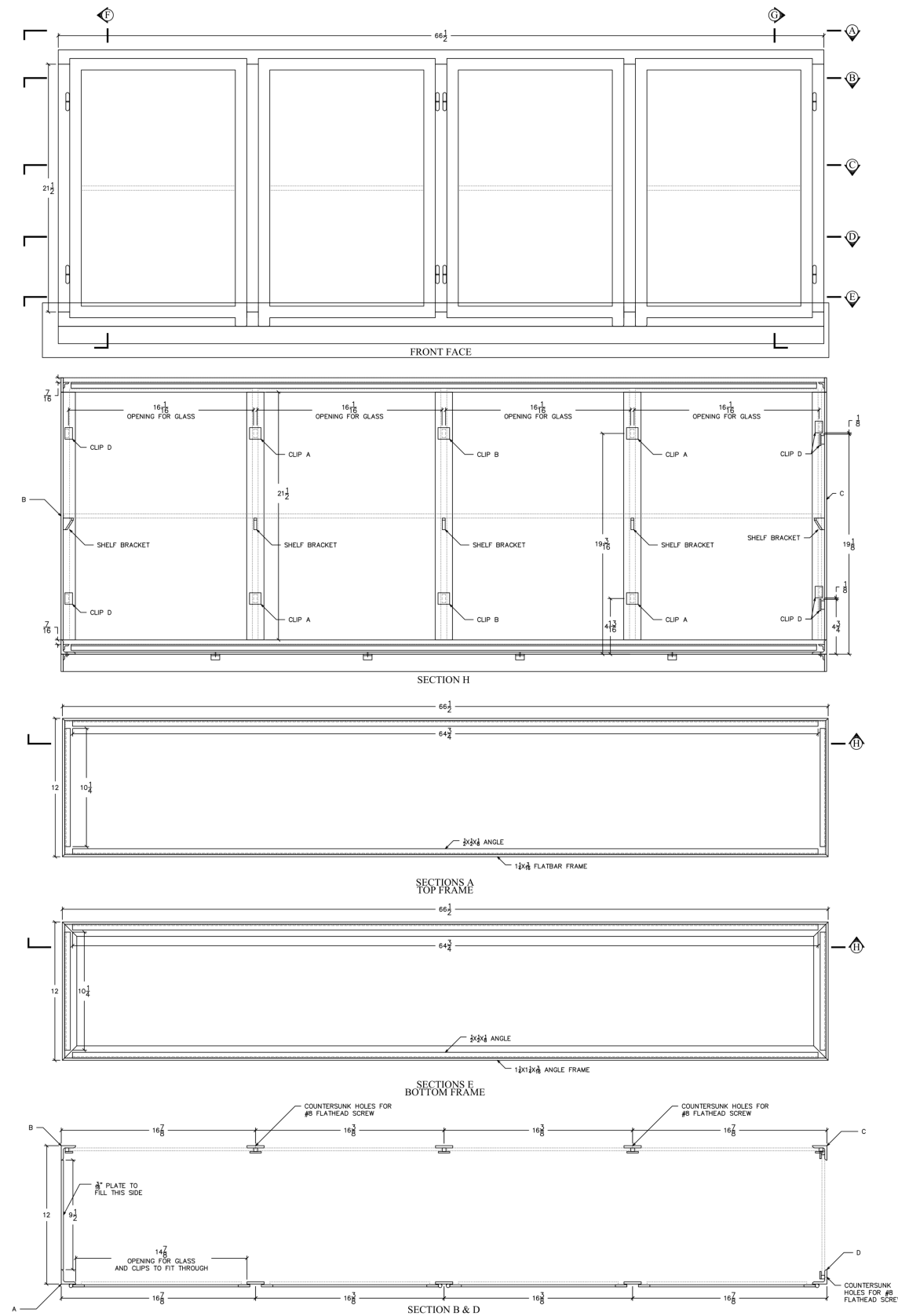

- MATERIALS:**
- TOP FRAME 1 1/2" x 1/2" FLATBAR
 - BOTTOM FRAME 1 1/2" x 1/2" x 1/8" ANGLE
 - TOP & BOTTOM GLASS SUPPORTS 3/4" x 1/2" x 1/8" ANGLE
 - CORNERS 1 1/2" x 1/2" x 1/8" ANGLE
 - VERTICALS, FRONT & BACK 1 1/2" x 1/2" FLATBAR
 - GLASS CLIPS 1/8" SQ BAR & 1X 1/4" FLATBAR
- GLASS:**
- TOP & BOTTOM 3/8" x 11 1/2" x 66" QTY 2
 - SHELF 1/8" x 11 x 65 1/2" QTY 1
 - DOORS 1/2" x 13 1/2" x 21" QTY 4
 - BACK 1/2" x 15 1/8" x 21 1/2" QTY 4
 - END 1/2" x 10 1/8" x 21 1/2" QTY 1

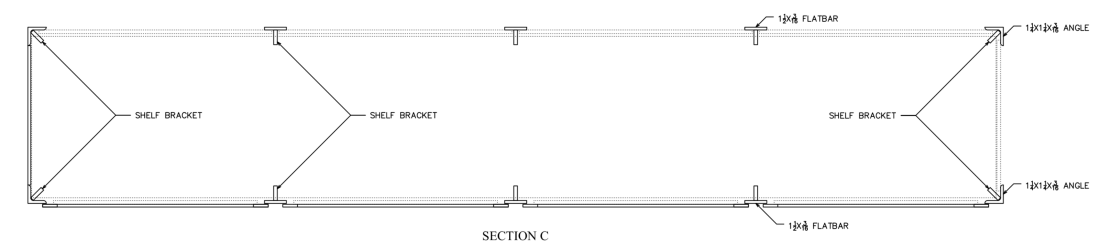

STEEL

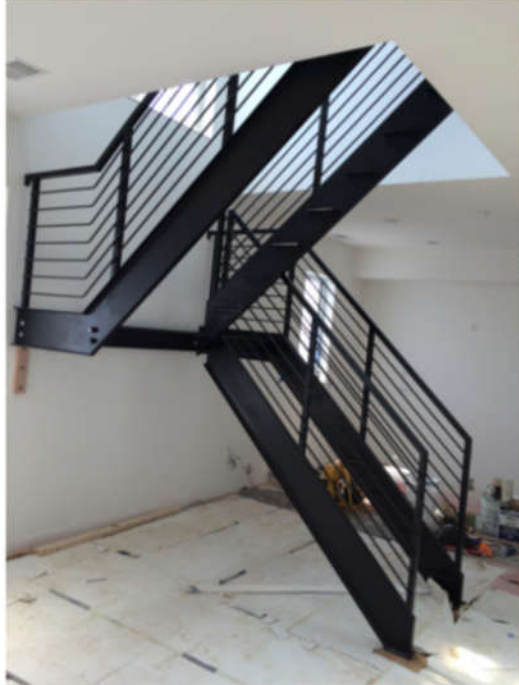
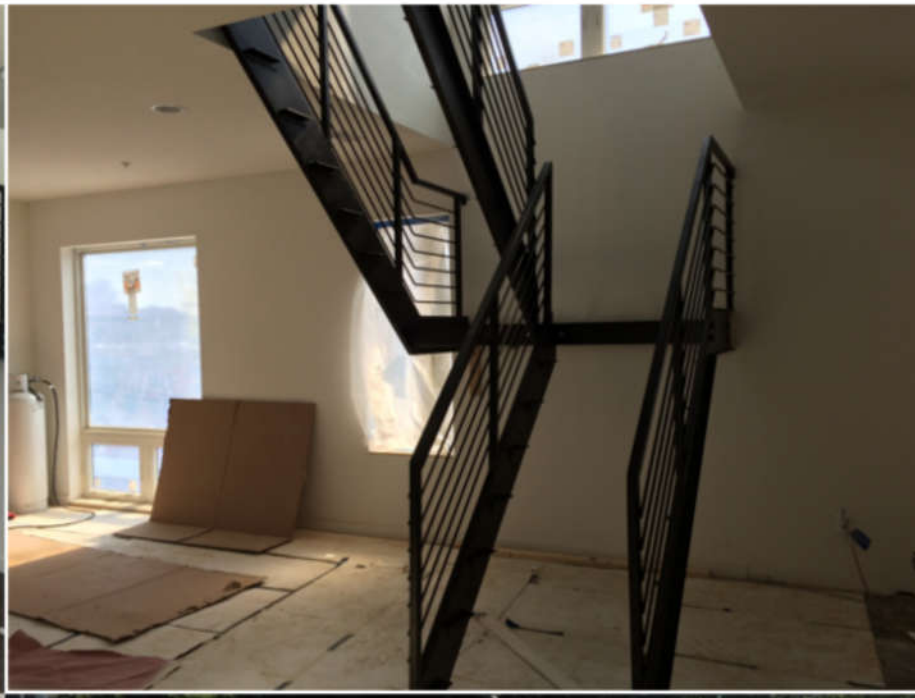
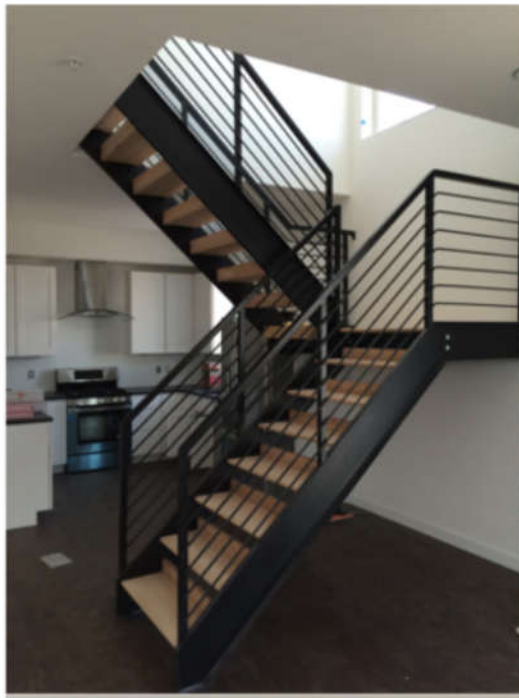

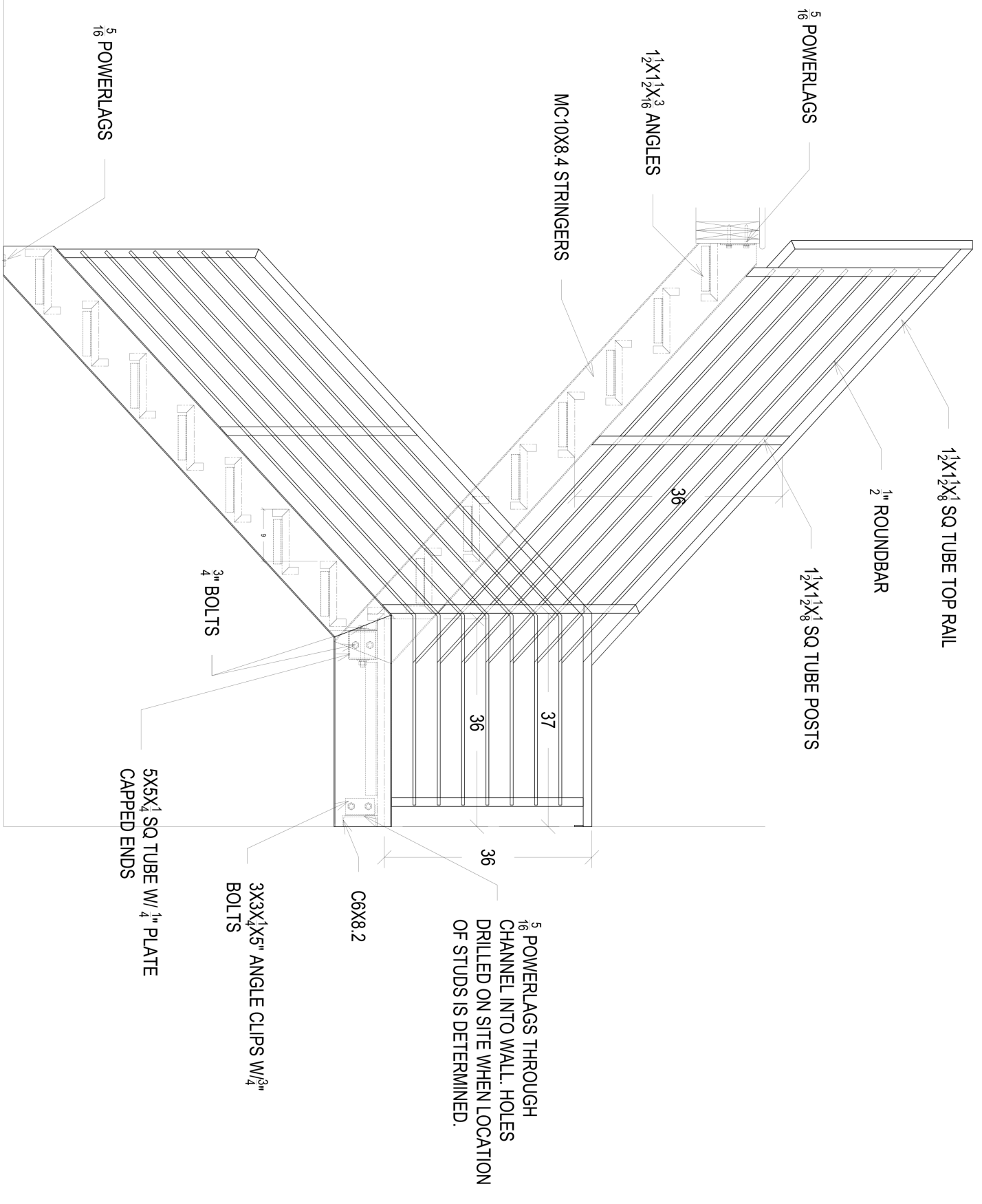
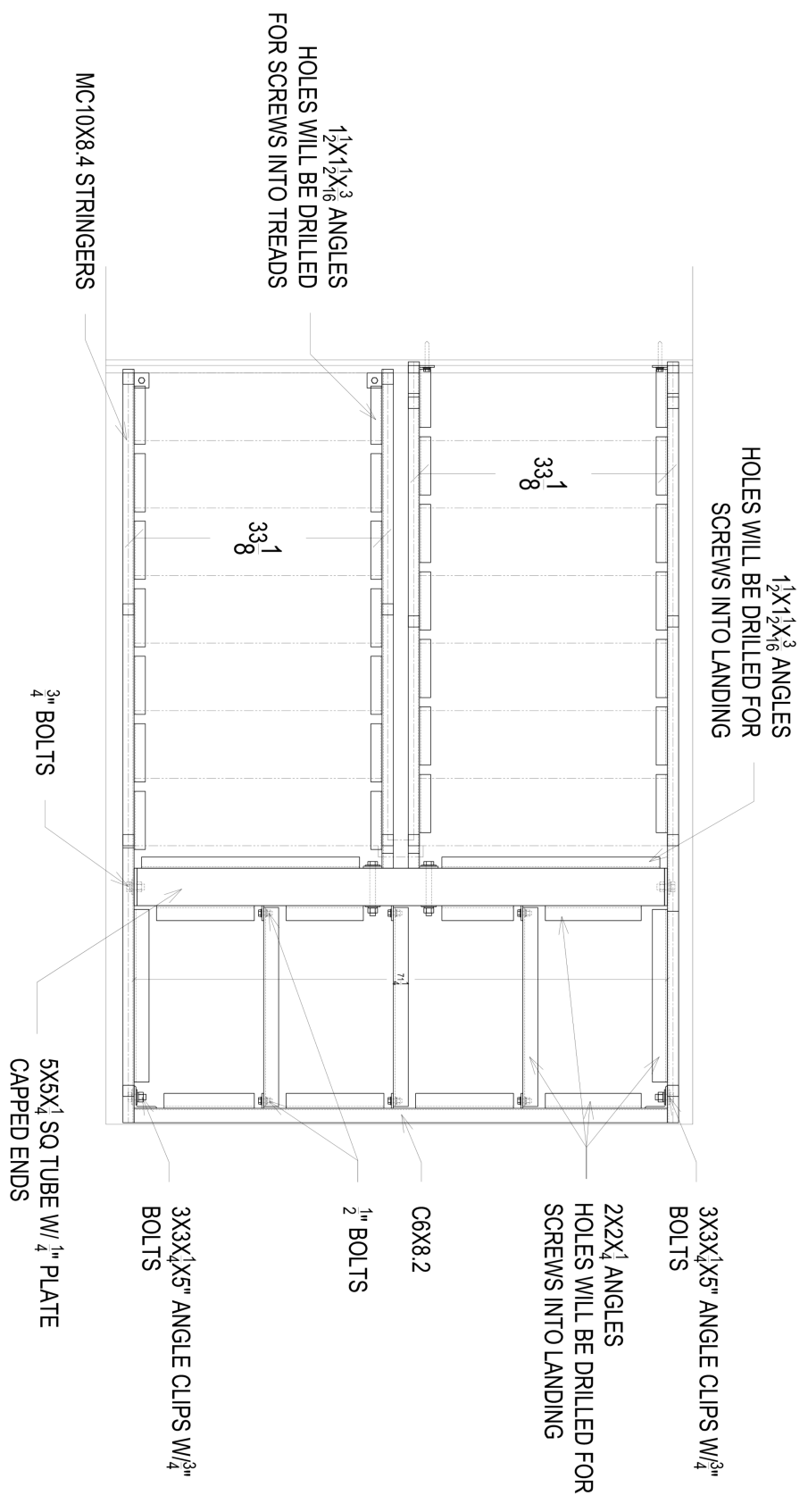

DRAWN: EY	BenFish, Inc.	W. Thompson St
DATE: 2/26/16	801 Cappon's Crossing, Suite 7, Pottsville, PA 19362	
REV: 0	Phone: 610.436.3100 Fax: 610.426.9200	
<small>Changes and all amendments are property of BenFish, Inc.</small>		

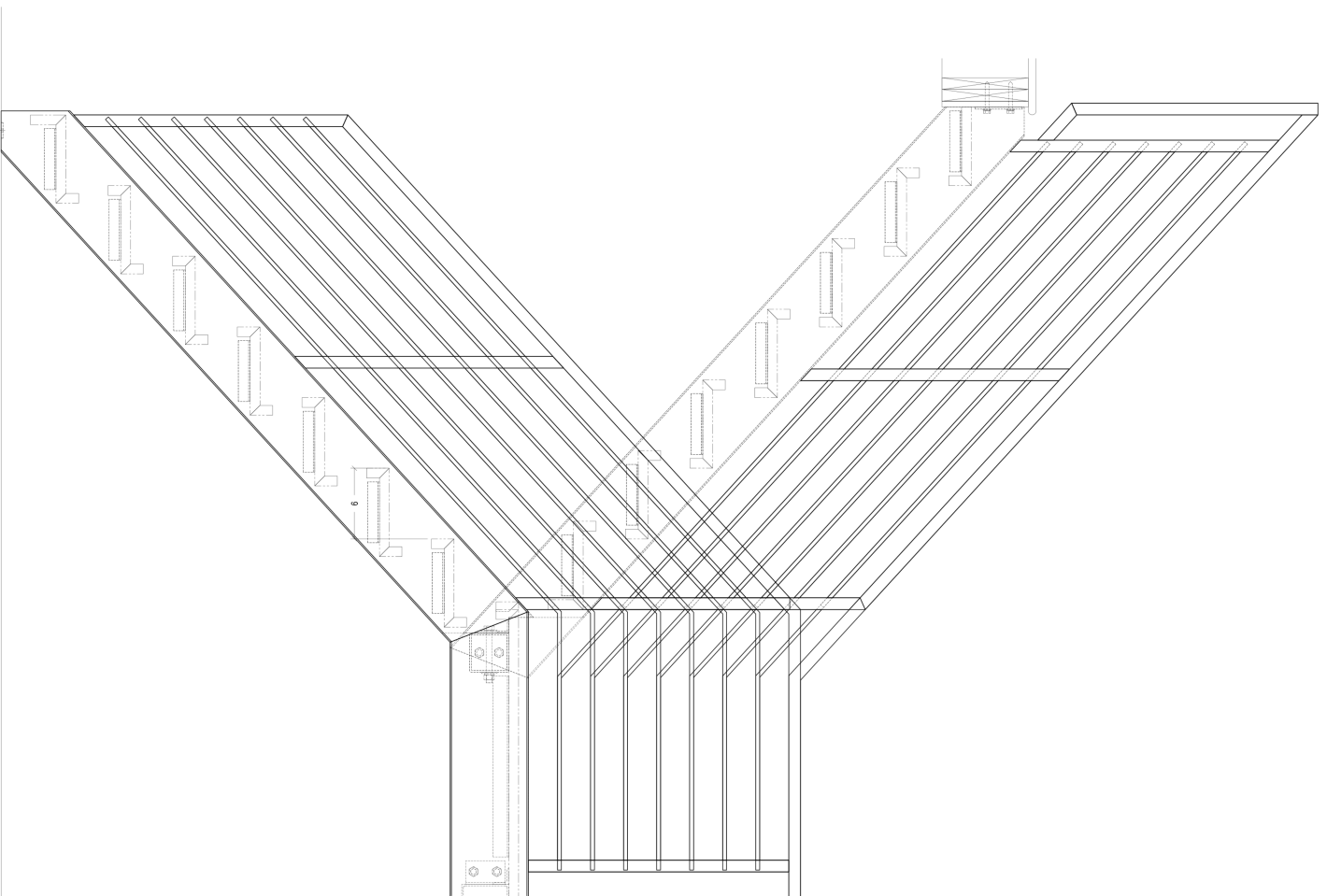
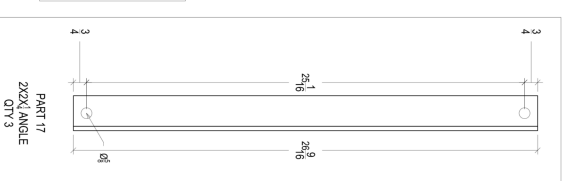
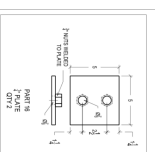
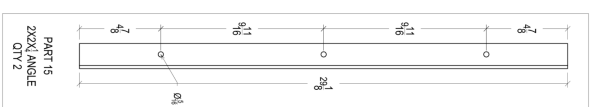
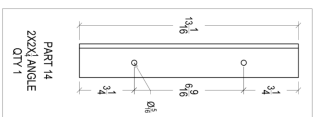
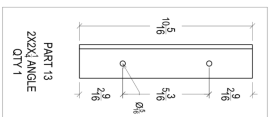
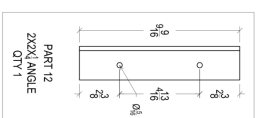
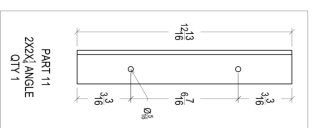
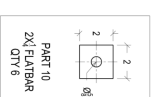
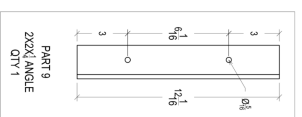
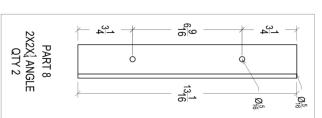
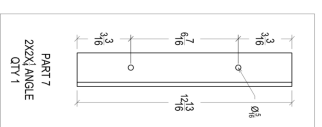
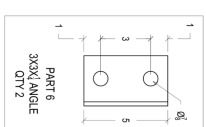
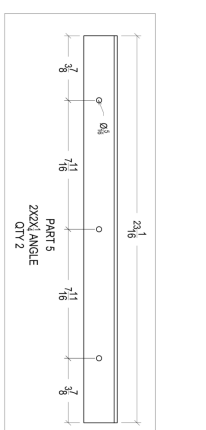
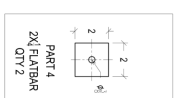
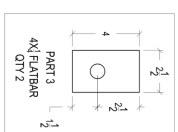
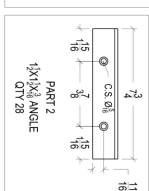
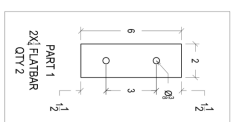
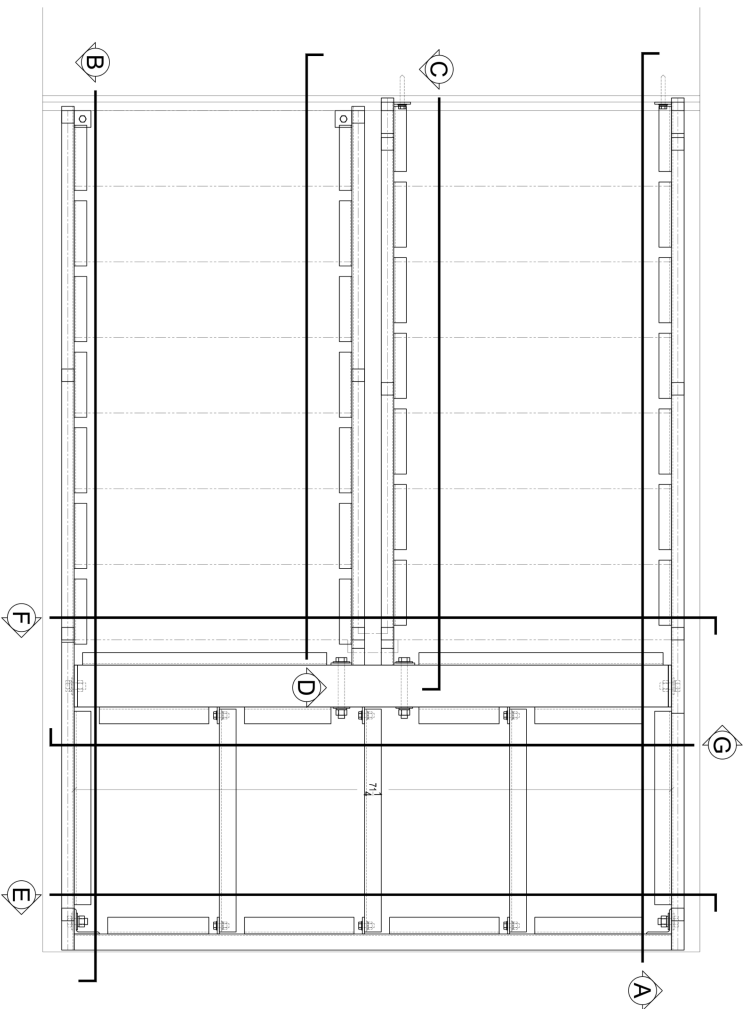

- MATERIALS:**
- 3X3 BOLTS QTY 8
 - 3X7 BOLTS QTY 2
 - 3X2 BOLTS QTY 6
 - 3/4 POWERGLASS QTY 18
 - 3/4 NUTS QTY 10
 - 3/4 FLAT WASHERS QTY 20
 - 3/4 LOCK WASHERS QTY 10
 - 3/4 NUTS QTY 6
 - 3/4 FLAT WASHERS QTY 12
 - 2 LOCK WASHERS QTY 6
 - M/C10X8.4 CHANNEL STRINGERS
 - C8X8.2 CHANNEL BACK CHANNEL
 - TOP RAIL 1X1X1 SQ TUBE
 - POSTS 1X1X1 SQ TUBE
 - PICKETS 2 ROUND BAR

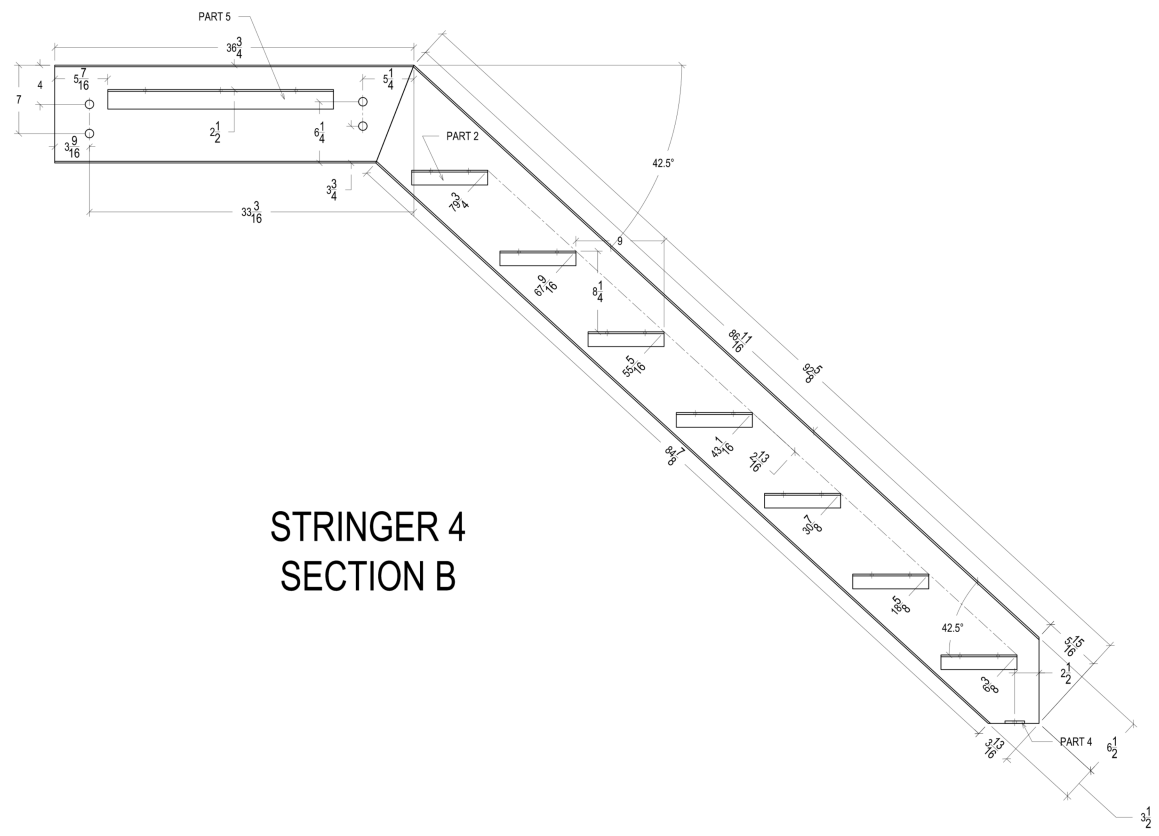
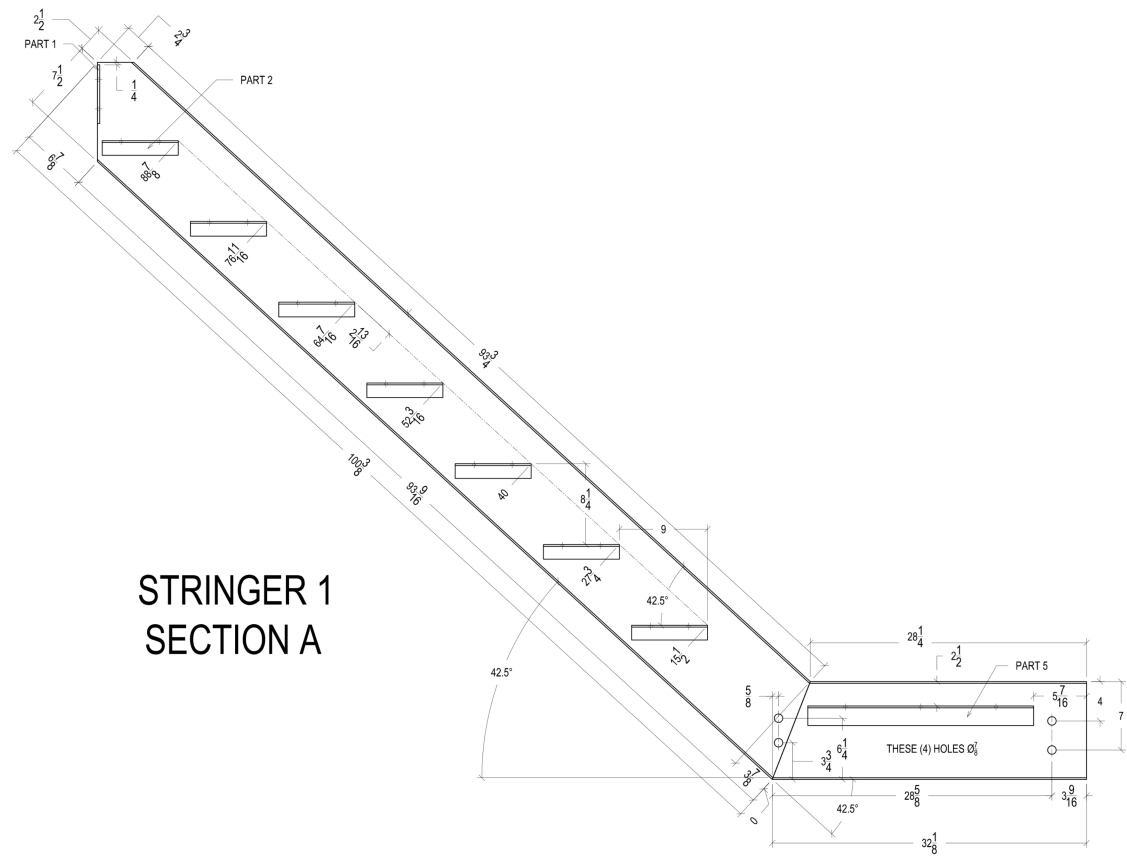
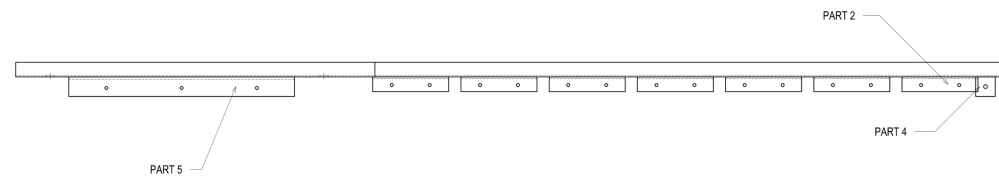
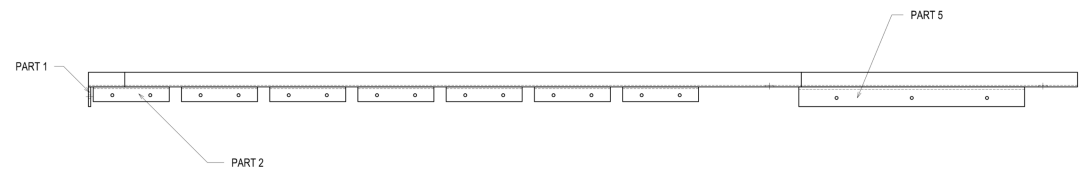

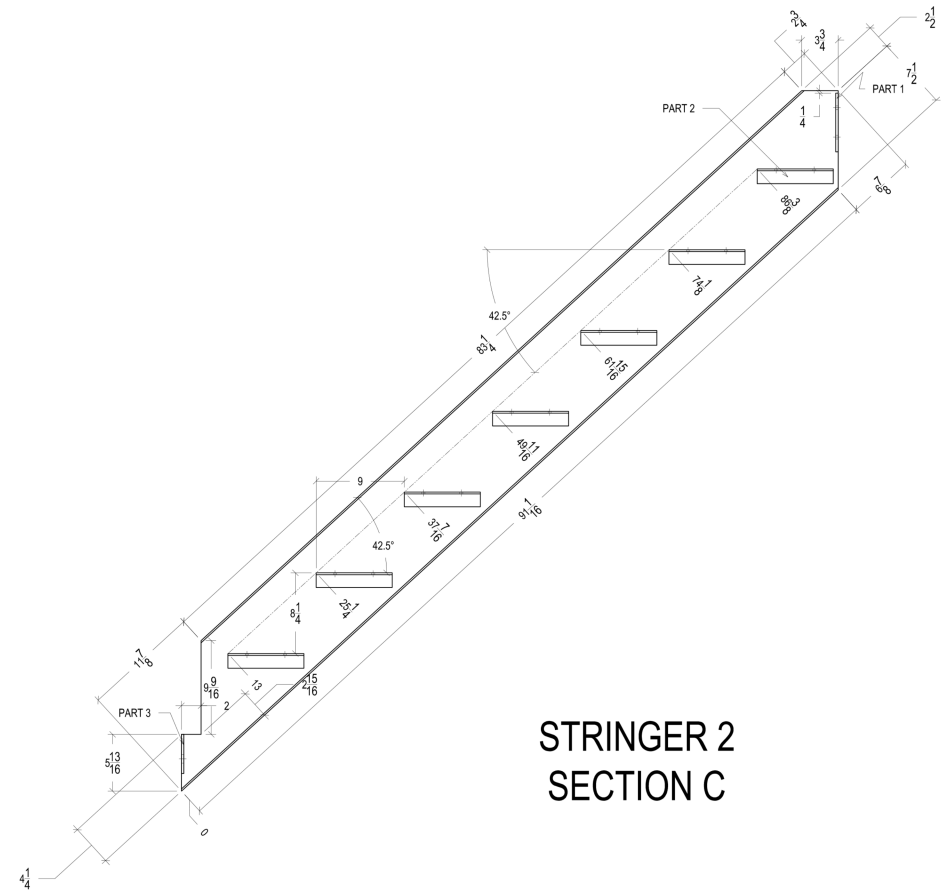
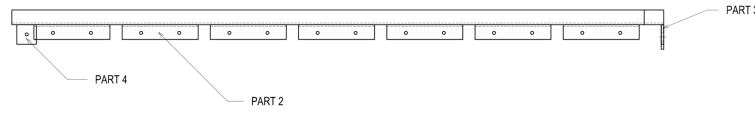
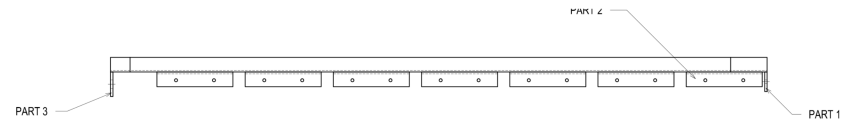

STRINGER 2
SECTION C

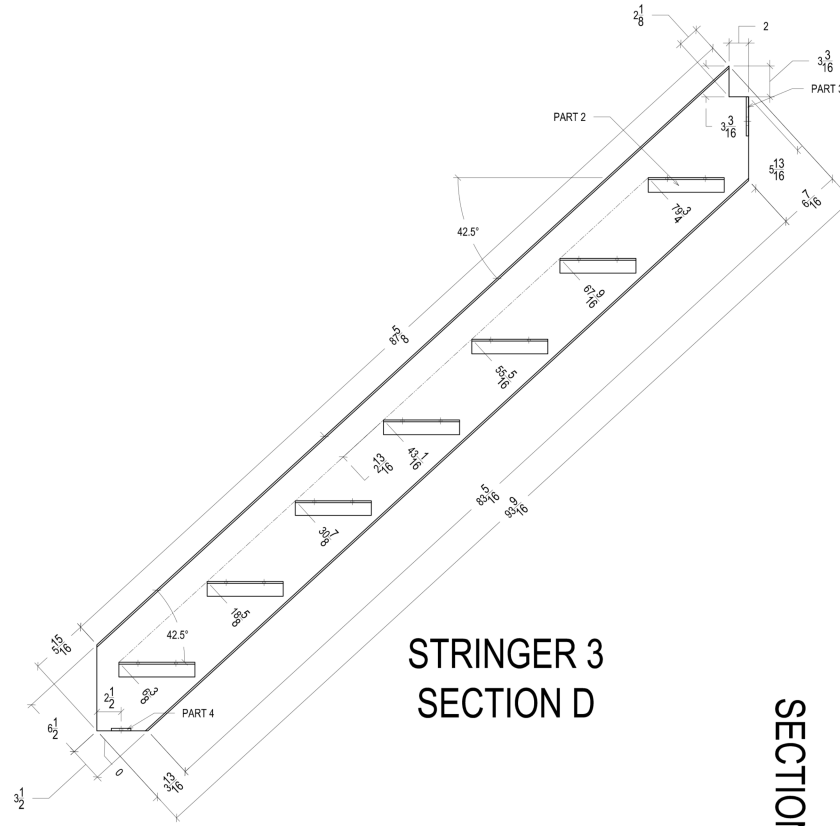

STRINGER 3
SECTION D

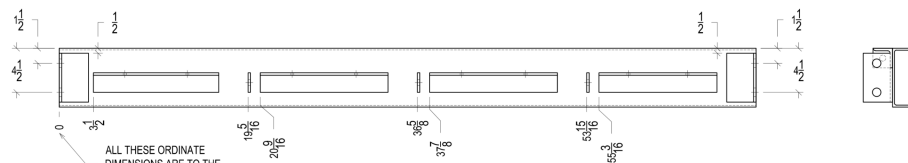
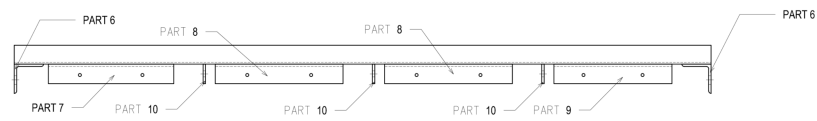

BACK CHANNEL
SECTION E

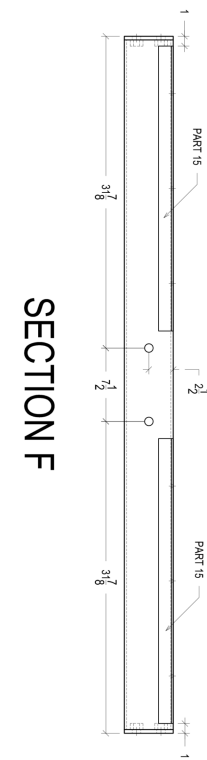

SECTION F

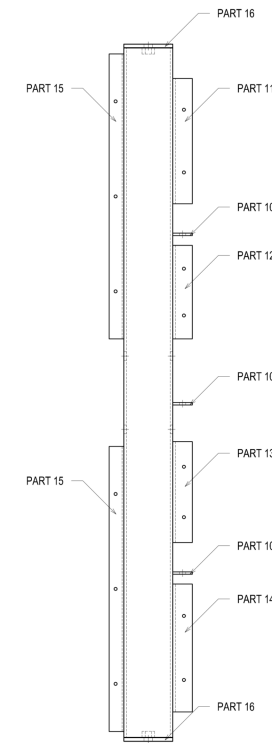

TUBE

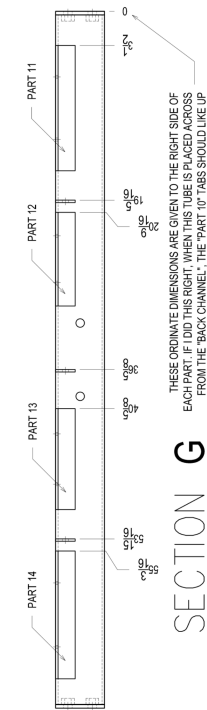

SECTION G

THESE ORDINATE DIMENSIONS ARE GIVEN TO THE RIGHT SIDE OF EACH PART. IF DID THIS RIGHT, WHEN THIS TUBE IS PLACED ACROSS FROM THE "BACK CHANNEL", THE "PART 10" TABS SHOULD LINE UP EXACTLY WITH EACH OTHER. THE ANGLES SHOULD NOT.

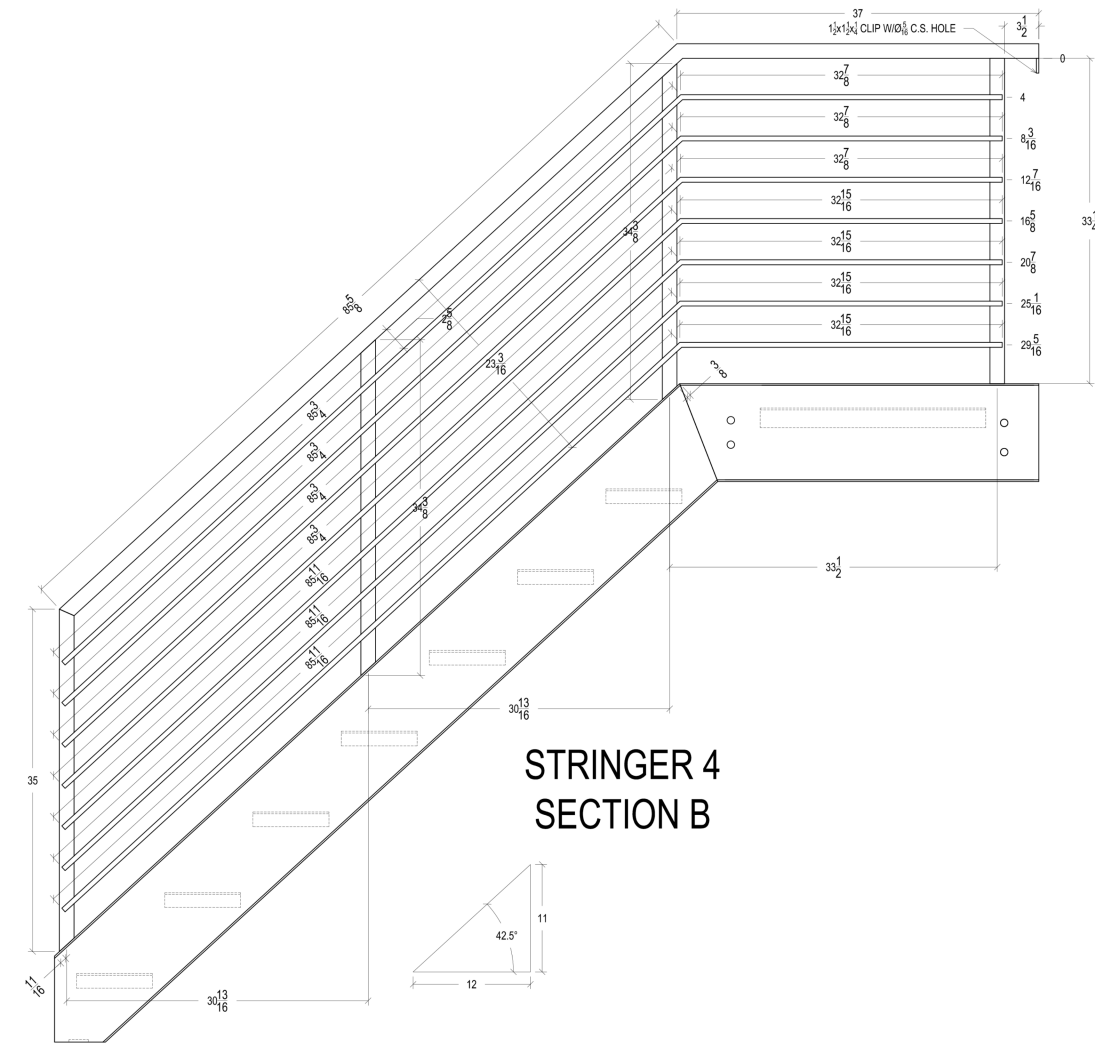
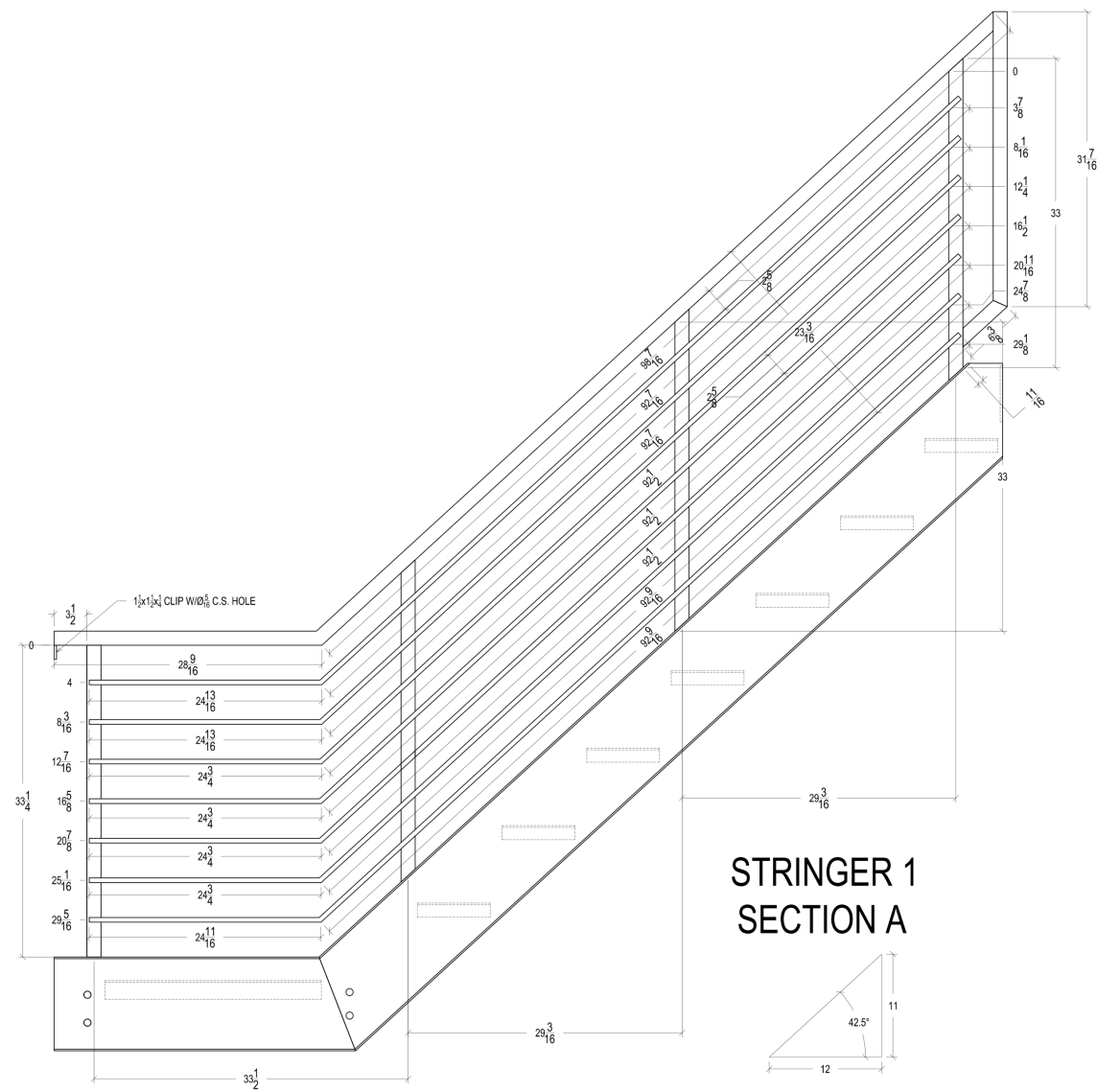

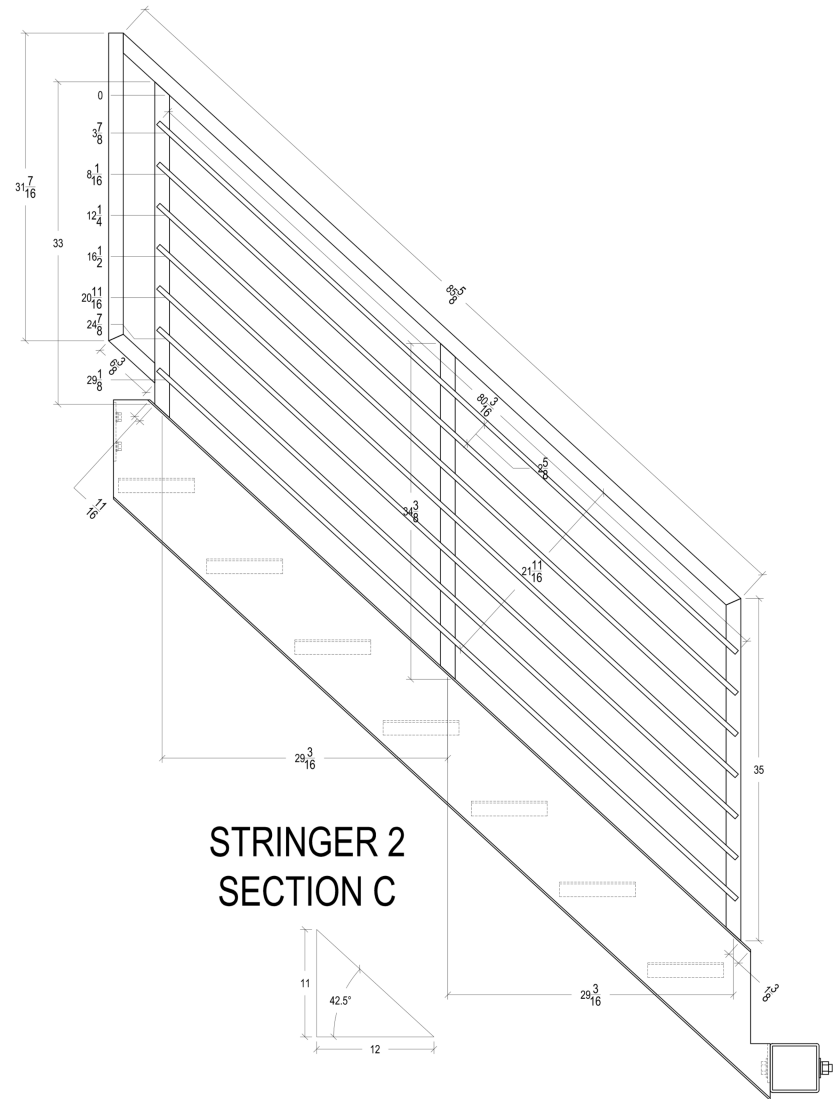

STRINGER 2
SECTION C

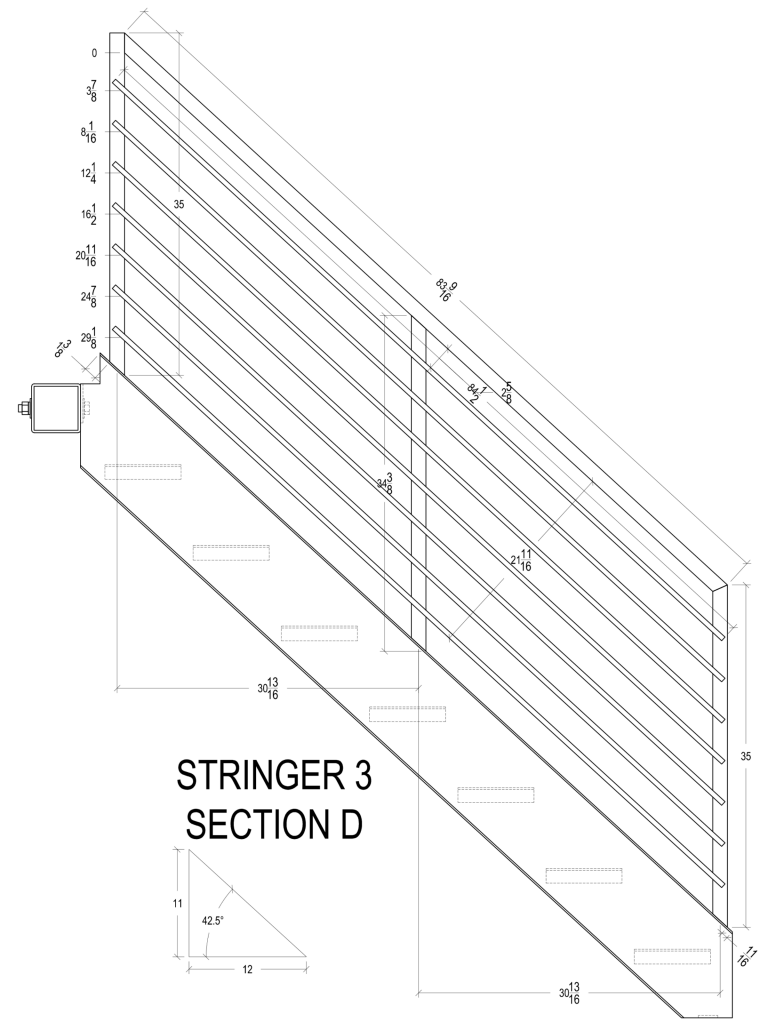

STRINGER 3
SECTION D

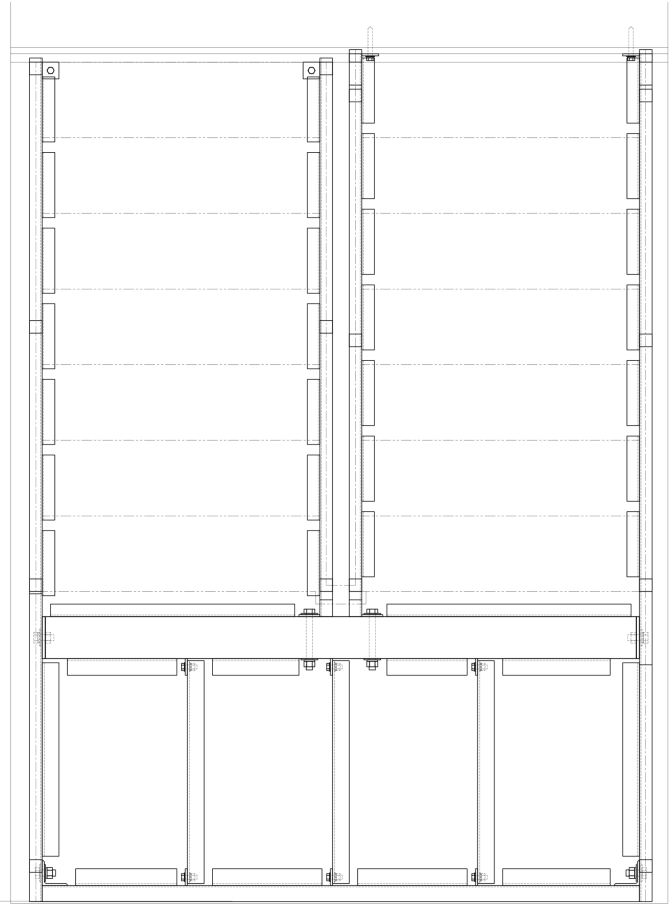
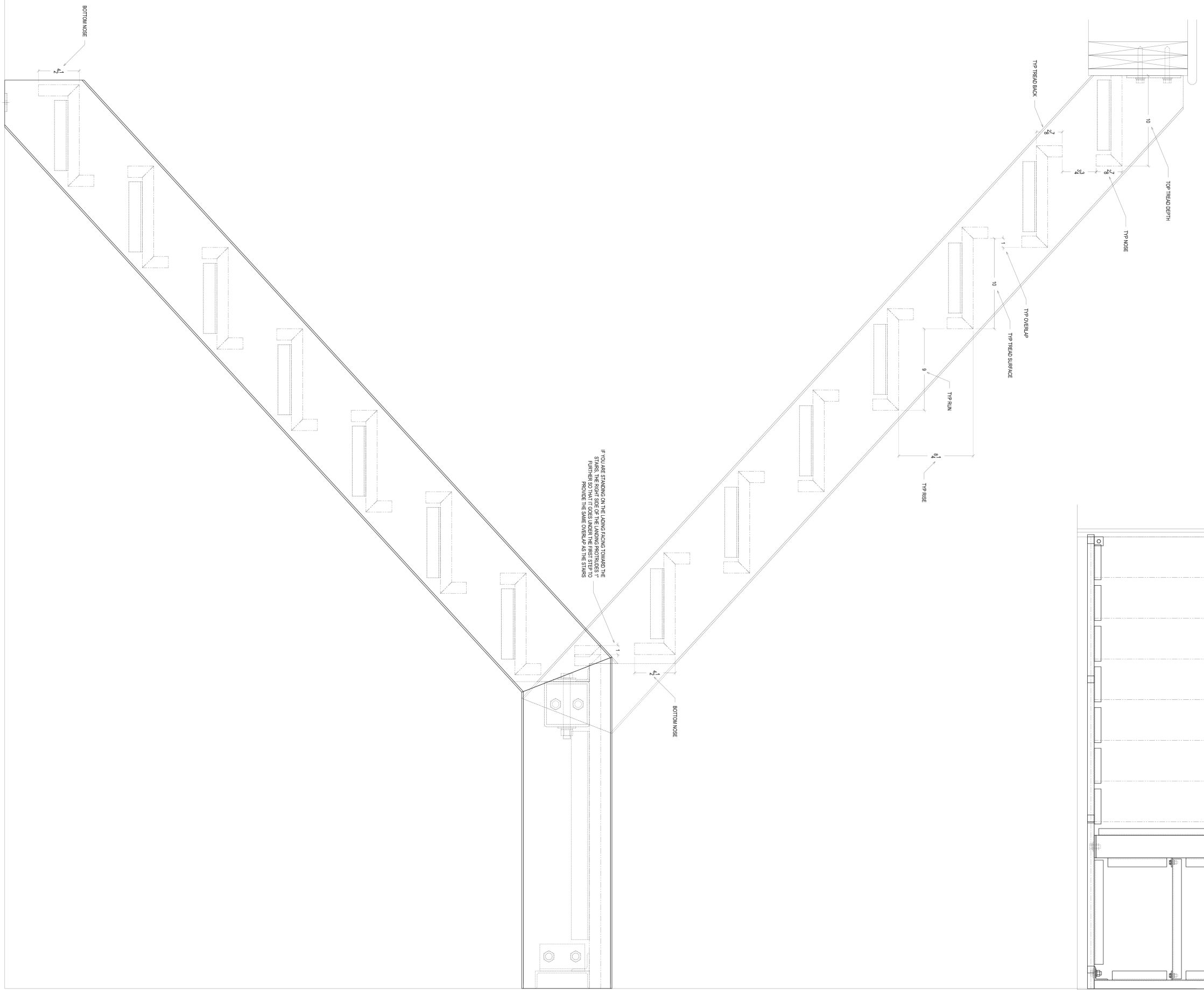



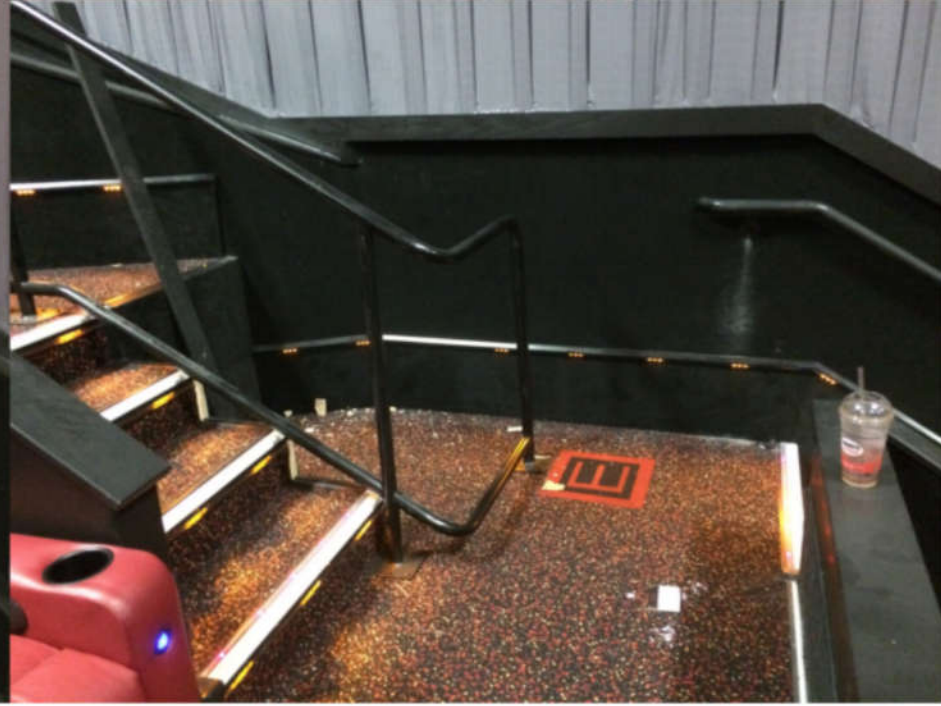

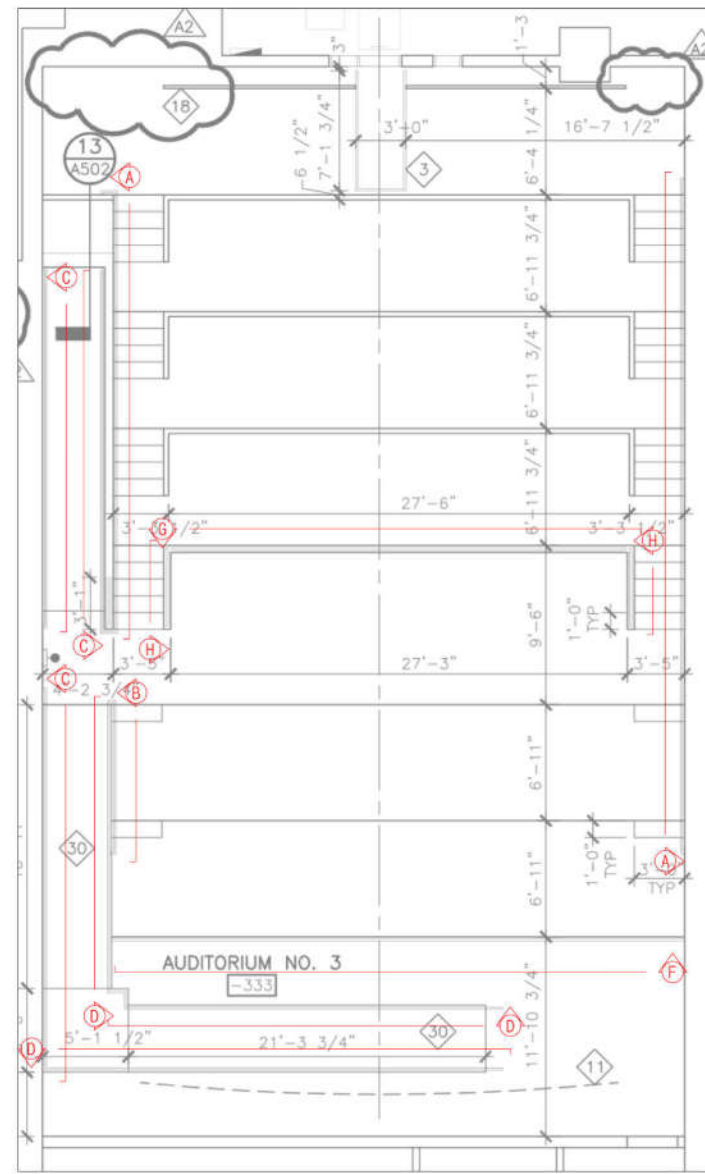
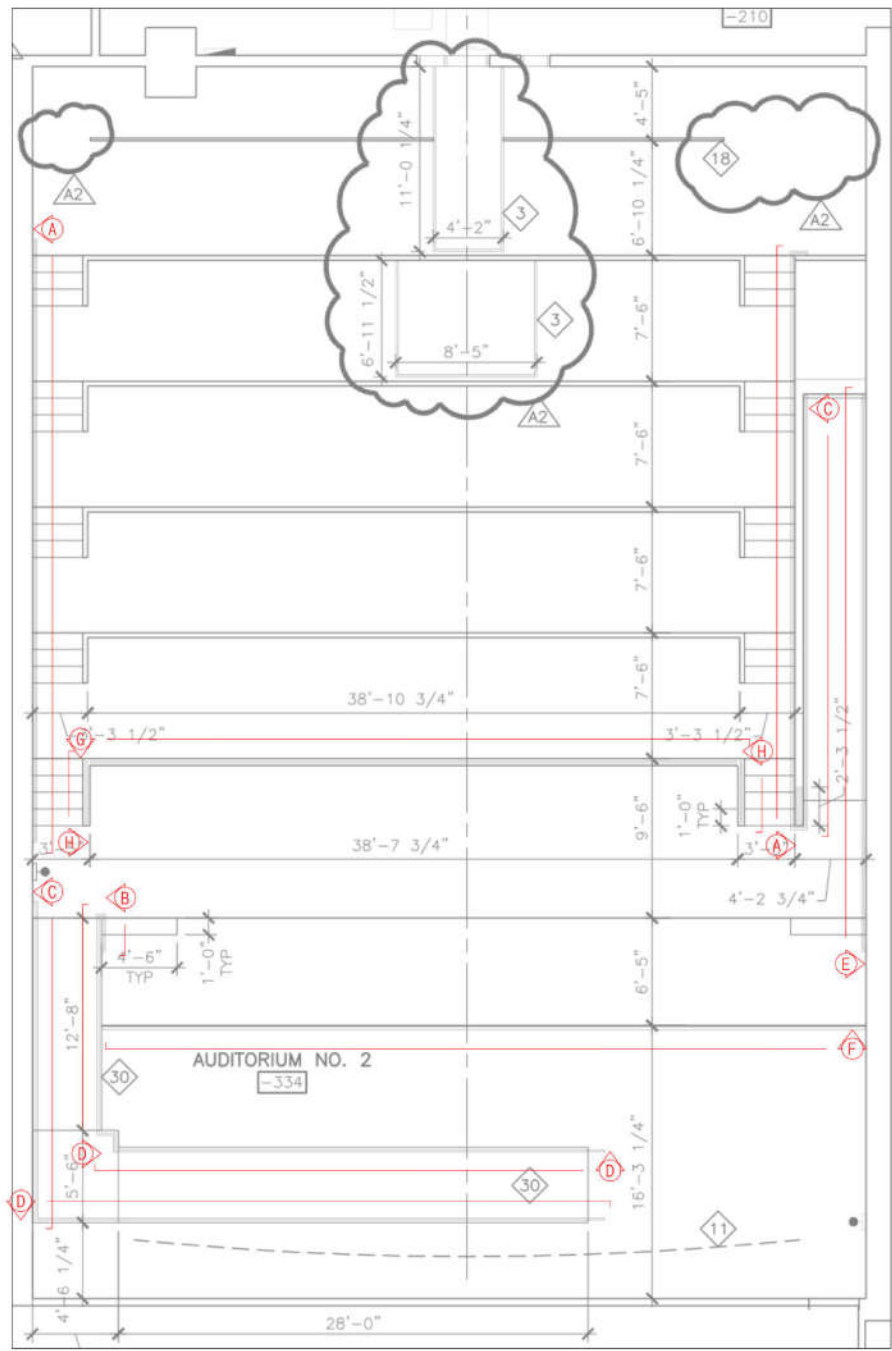
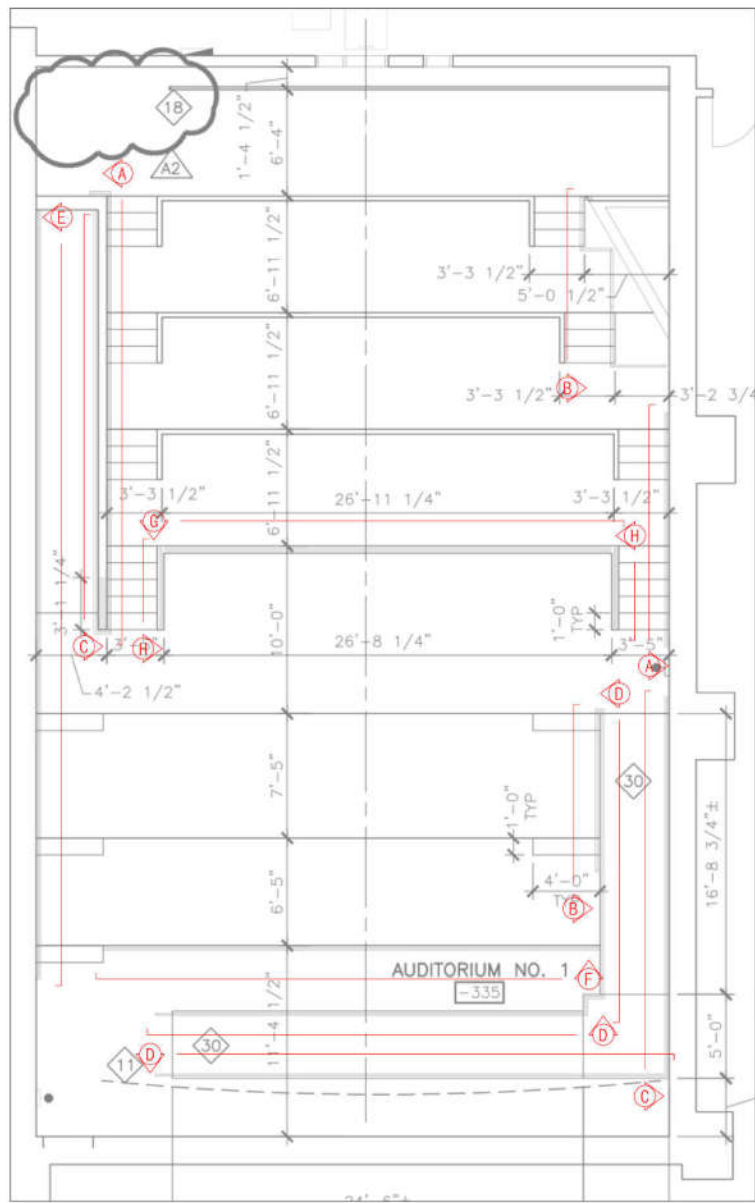

DRAWN: EY.
 DATE: 3/17/16
 REV: 0

BenFab, Inc.
 801 Carpenters Crossing, Suite 8, Folcroft, PA 19032
 Phone: 610-626-9100 Fax: 610-626-9200
www.benfabrailings.com

AMC Georgetown
 TYPICAL SHOP
 DRAWINGS

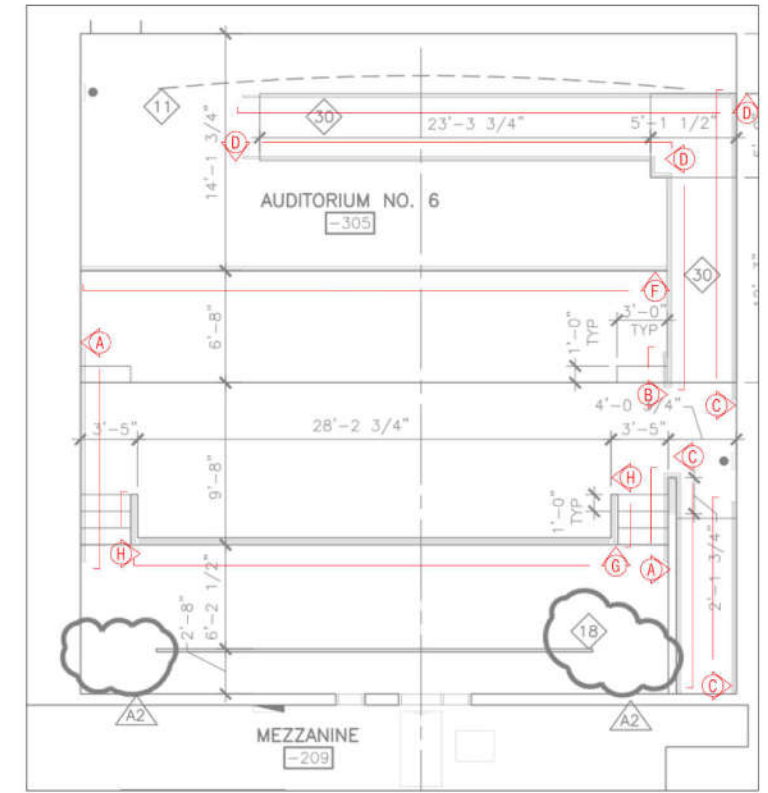
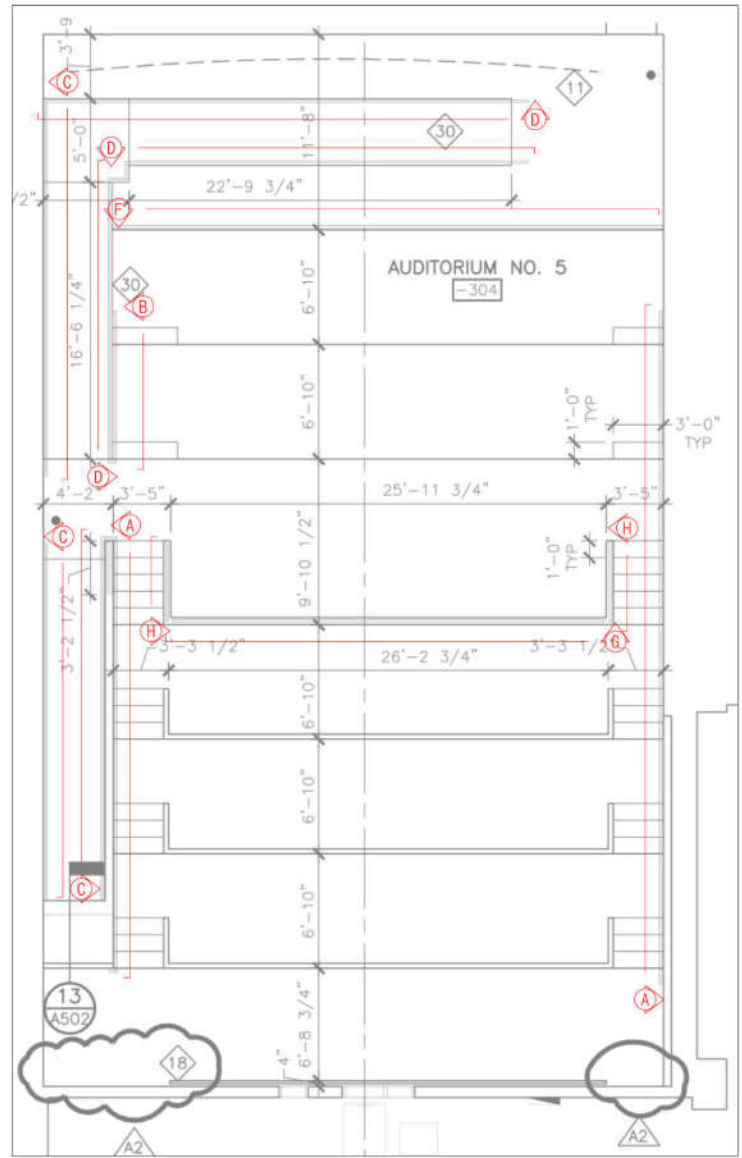
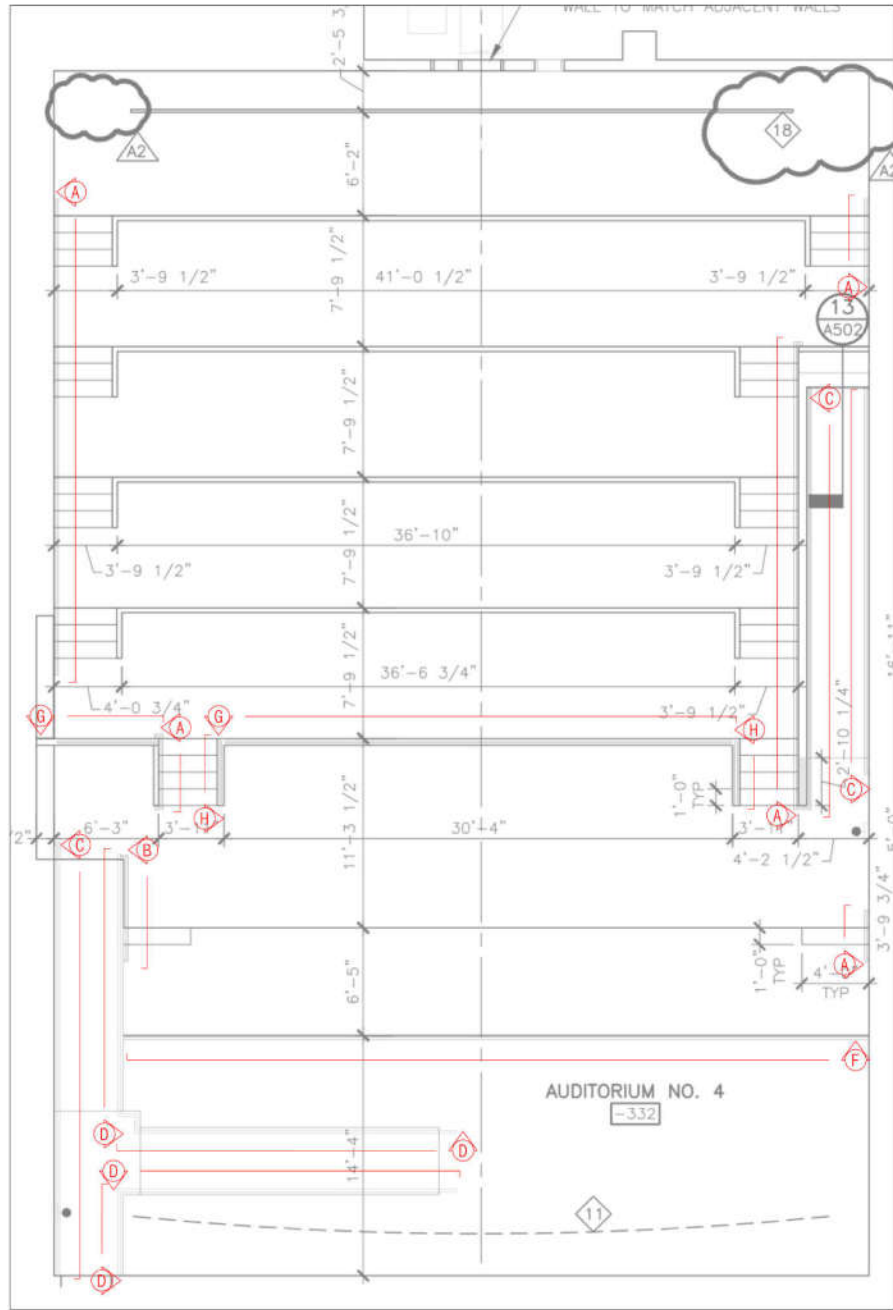

DRAWN: EY.
 DATE: 3/17/16
 REV: 0

BenFab, Inc.
 801 Carpenters Crossing, Suite 8, Folcroft, PA 19032
 Phone: 610-626-9100 Fax: 610-626-9200
www.benfabrailings.com

AMC Georgetown
 TYPICAL SHOP
 DRAWINGS

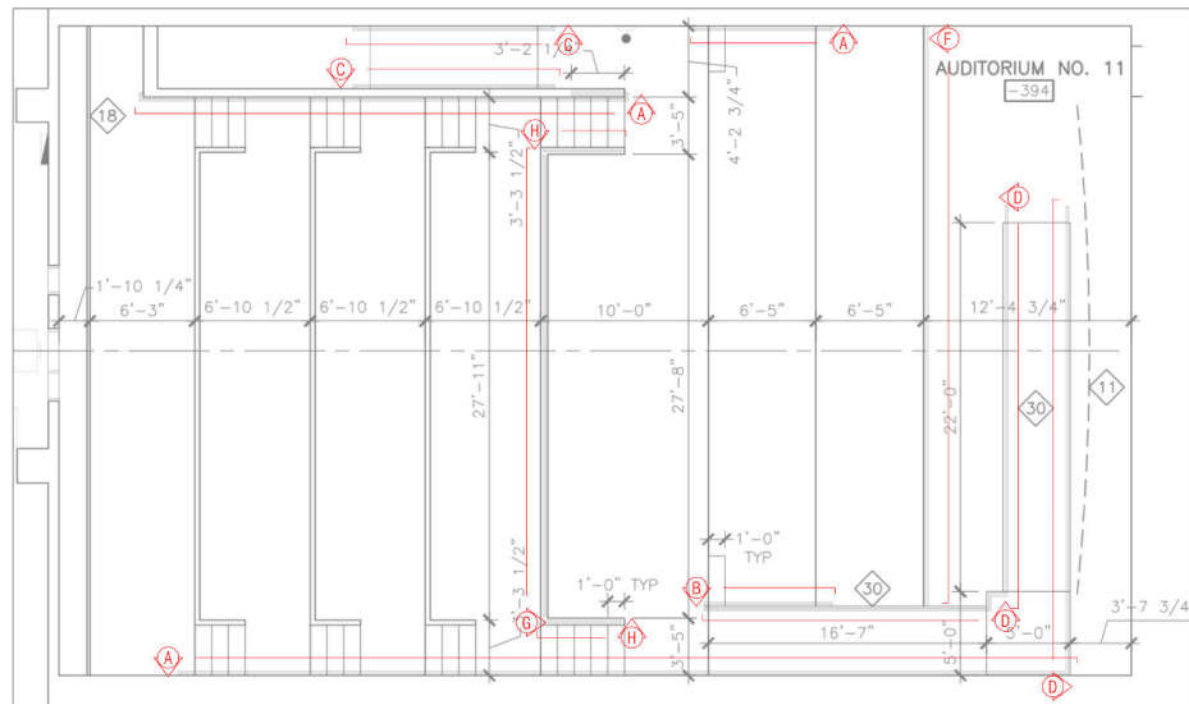
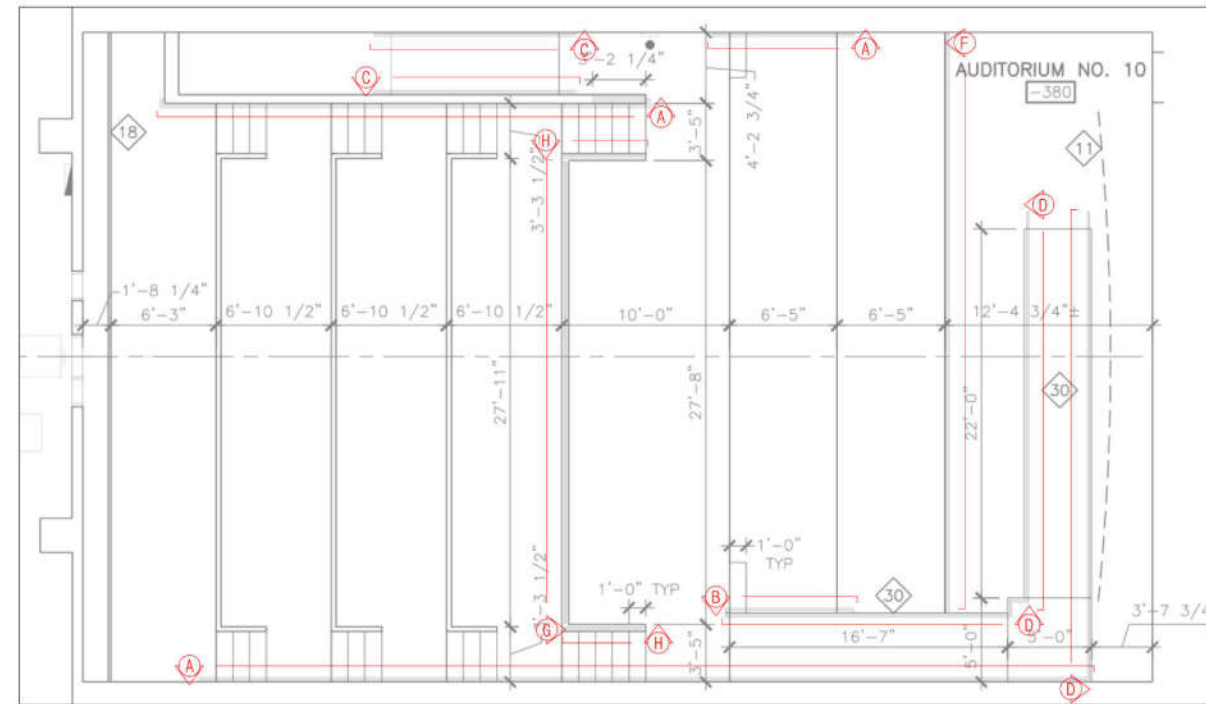
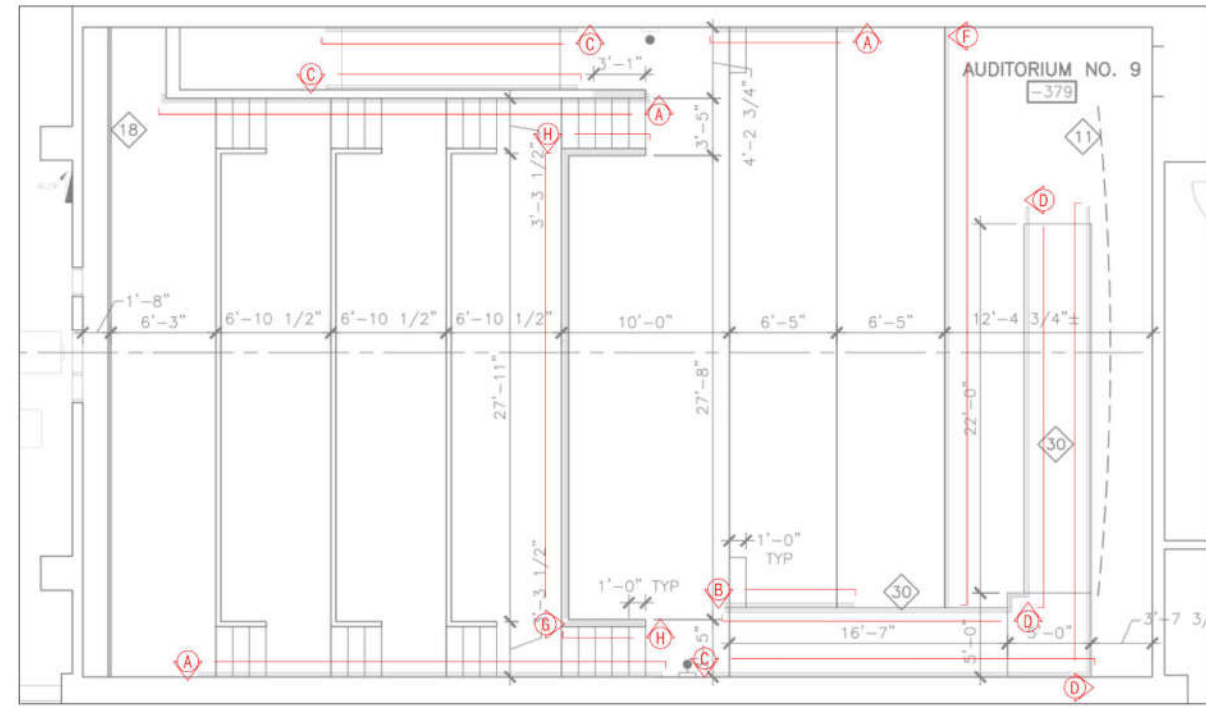
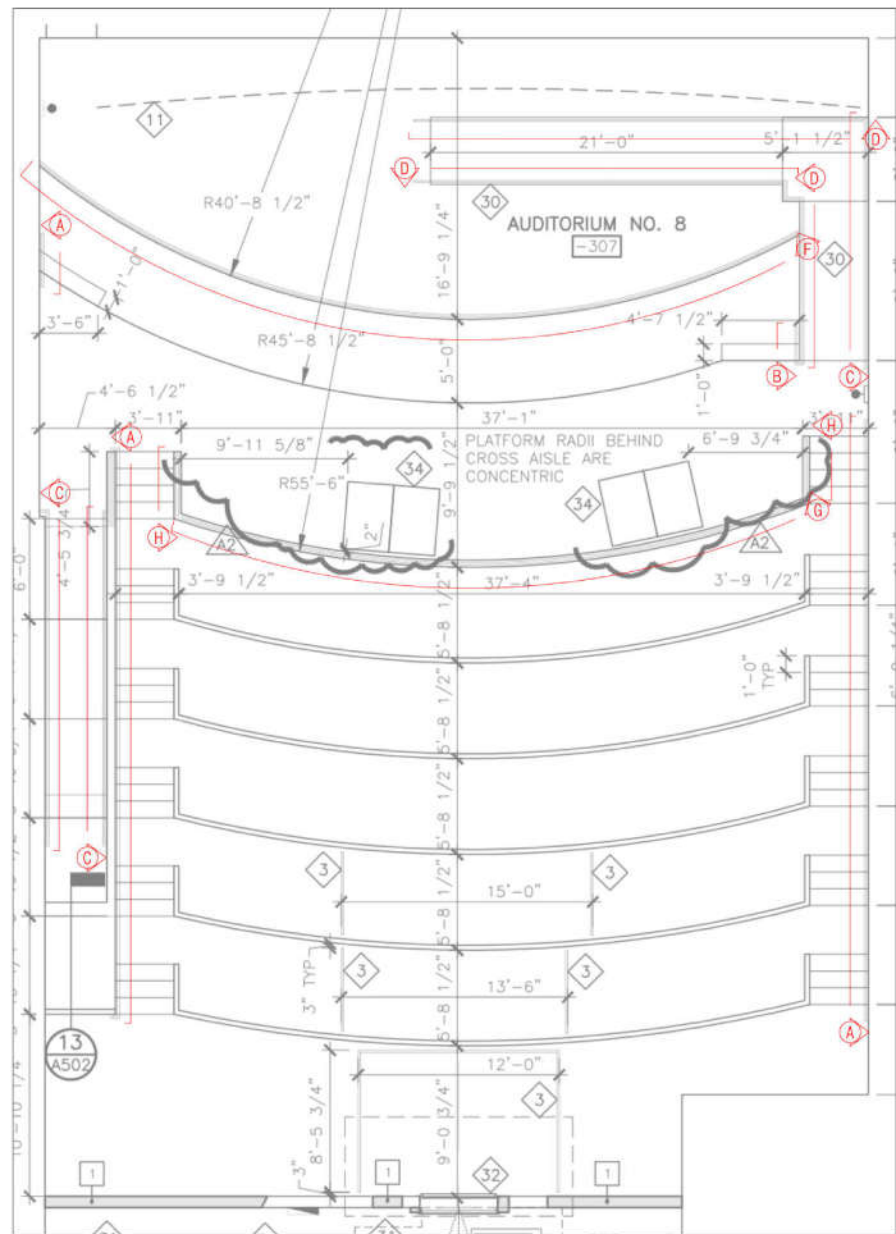

DRAWN: EY.
DATE: 3/17/16
REV: 0

BenFab, Inc.
801 Carpenters Crossing, Suite 8, Folcroft, PA 19032
Phone: 610-626-9100 Fax: 610-626-9200
www.benfabrailings.com

AMC Georgetown
TYPICAL SHOP
DRAWINGS

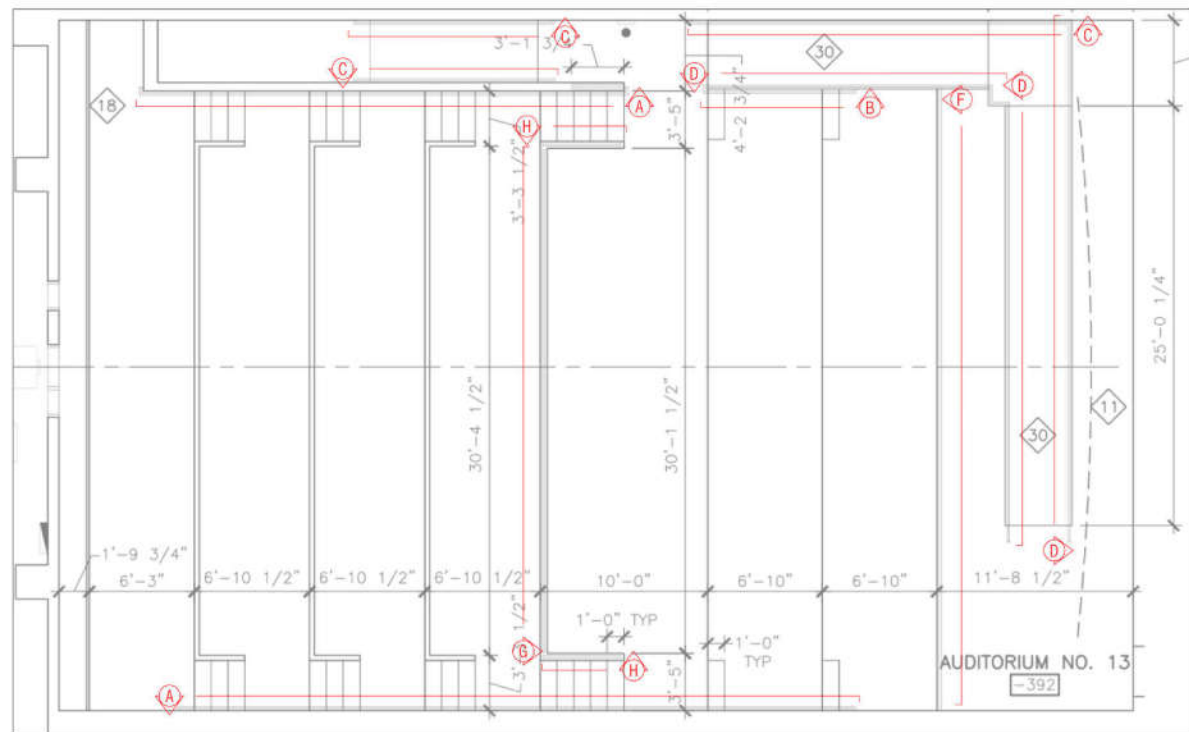
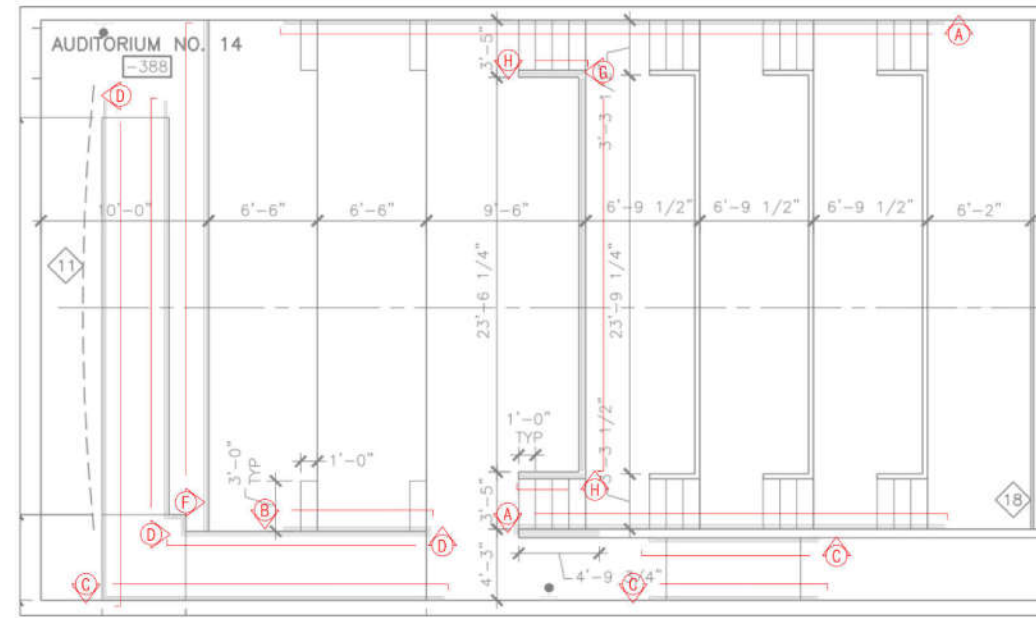
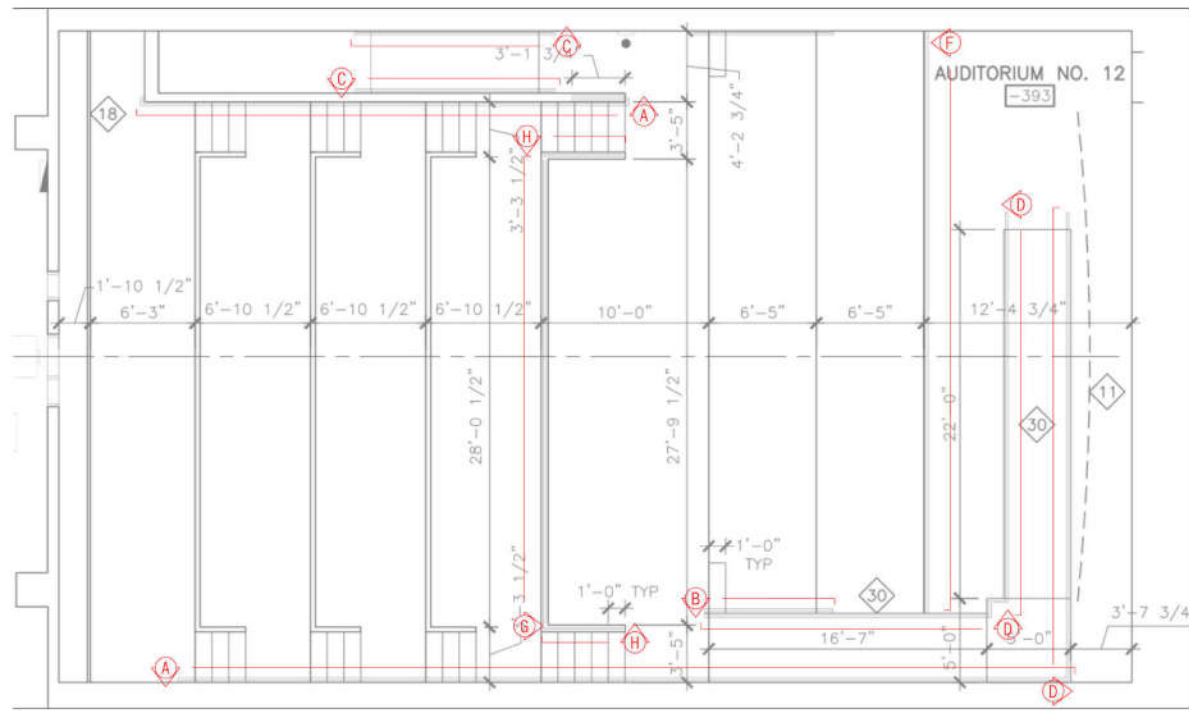

DRAWN: EY.	BenFab, Inc. 801 Carpenters Crossing, Suite 8, Folcroft, PA 19032 Phone: 610-626-9100 Fax: 610-626-9200 www.benfabrailings.com	AMC Georgetown TYPICAL SHOP DRAWINGS
DATE: 3/17/16		
REV: 0		

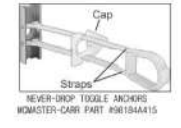

- NOTES:
- ALL HANDRAILINGS AND POSTS ARE 1 1/2" SCH 40 STEEL PIPE
 - ALL FIELD SPLICES WILL BE WELDED, GROUND SMOOTH AND PAINT TOUCHED UP
 - ALL WALL MOUNTED RAILINGS WILL HAVE A GAP OF 1/8" BETWEEN RAILING AND WALL
 - ALL WALL RETURNS WILL HAVE A 1/2" GAP BETWEEN END OF RETURN AND WALL
 - ALL PIPE BENDS WILL HAVE A CENTERLINE RADIUS OF 3 1/2"
 - IF WALL MOUNTED RAILS ATTACH TO TRIPLE LAYERS OF DRYWALL, NEVER-DROP TOGGLE ANCHORS WILL BE USED W/ 3/20 HEX HEAD BOLTS
 - IF WALL MOUNTED RAILS ATTACH TO A SINGLE LAYER OF DRYWALL, WE WILL DISCUSS OPTIONS FOR BLOCKING

ALL POST MOUNTING BASEPLATES TO BE DETERMINED BY EXISTING FLOORING AS PER "POST MOUNTING DETAILS"

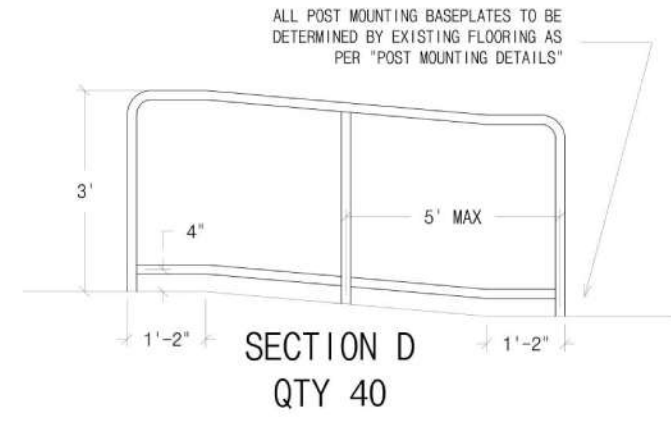
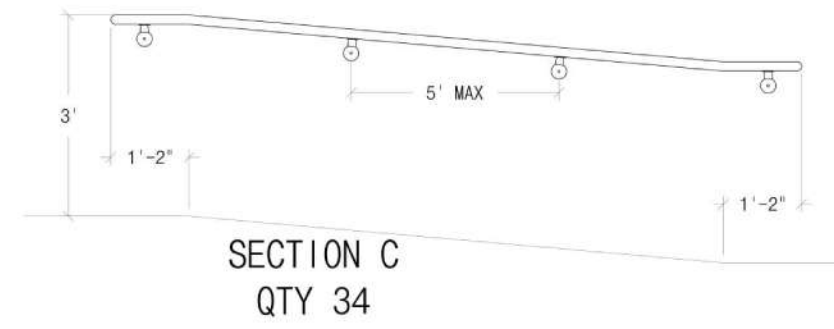
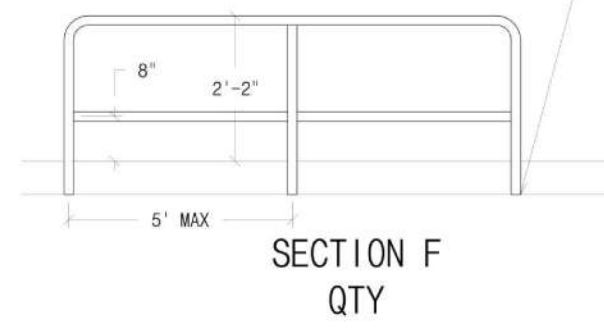
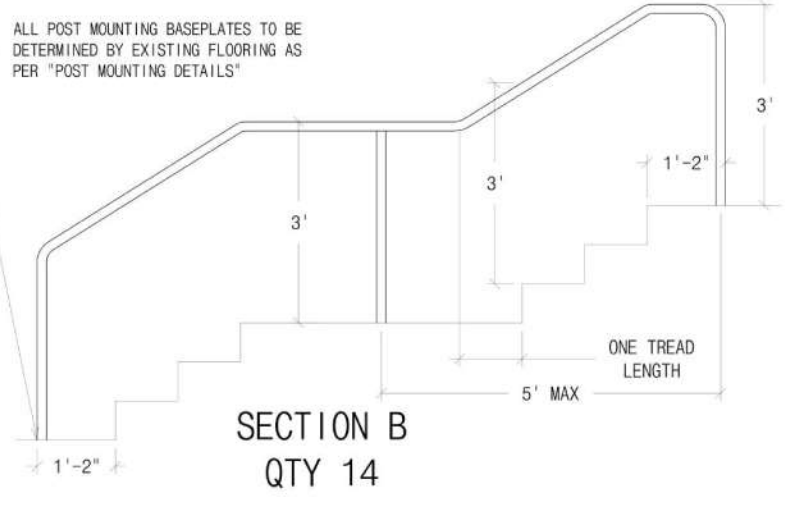
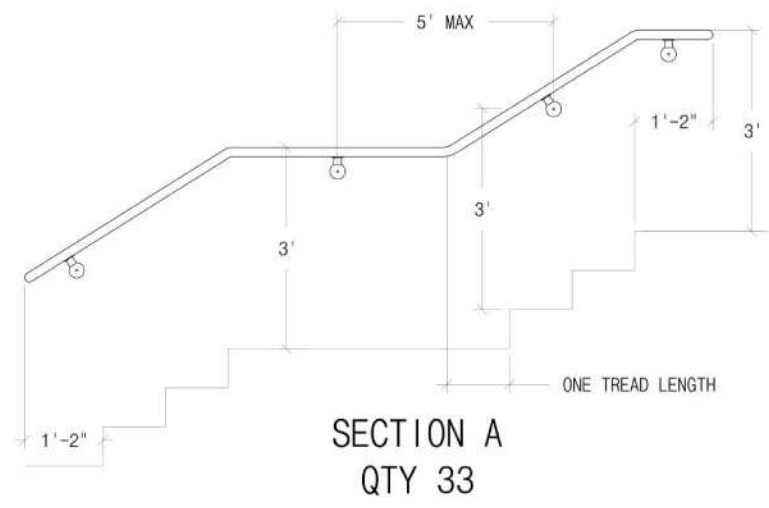

CABLE RAILING NOTES:
DETAIL 9 ON A503 CALLS FOR DIMENSIONS "A" AND "B" TO BE THE SAME, THIS DOESN'T WORK IF WE WANT TO KEEP THE CABLE SPACING LOOKING CONSISTENT. IN ORDER TO MAKE THAT WORK, DIMENSIONS "C" AND "D" MUST BE THE SAME.

DETAILS ON A502 ARE INCONSISTENT ABOUT WHETHER THE CABLE RAIL POSTS SHOULD BE MADE WITH SCH 40 OR SCH 80 PIPE. WE WOULD LIKE TO USE SCH 40 THROUGHOUT. IF WE USE SCH 80 FOR THE END POSTS, WHERE THE TOP RAIL MEETS THE END POSTS WILL NEED TO BE MITERED AND NOT BENT.

SECTION G
QTY 14

SECTION H
QTY 26

ATTACHED TO THIS DOCUMENT IS INFORMATION ABOUT THE CABLE HARDWARE WE ARE USING. THE SPECIFIC PIECES WE ARE USING FOR THE 1/2" CABLE ARE:

- SWAGING STUDS
- RADIUS FERRULES
- INVISIWARE RECEIVERS

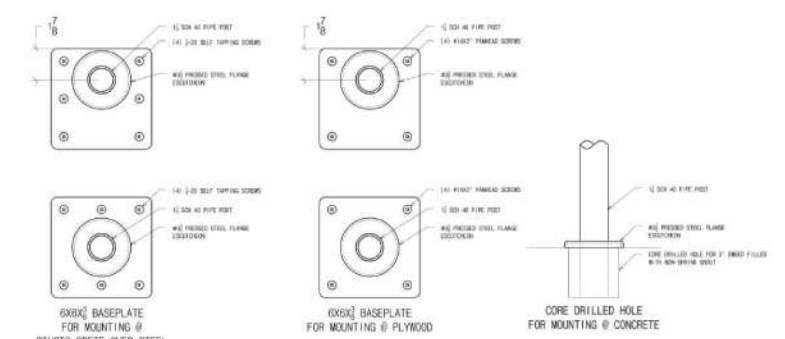
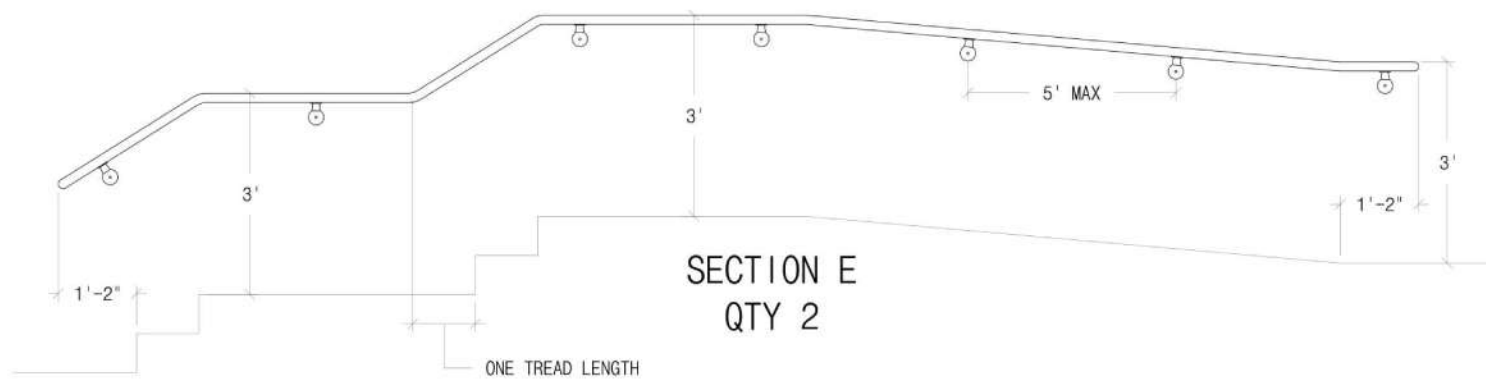

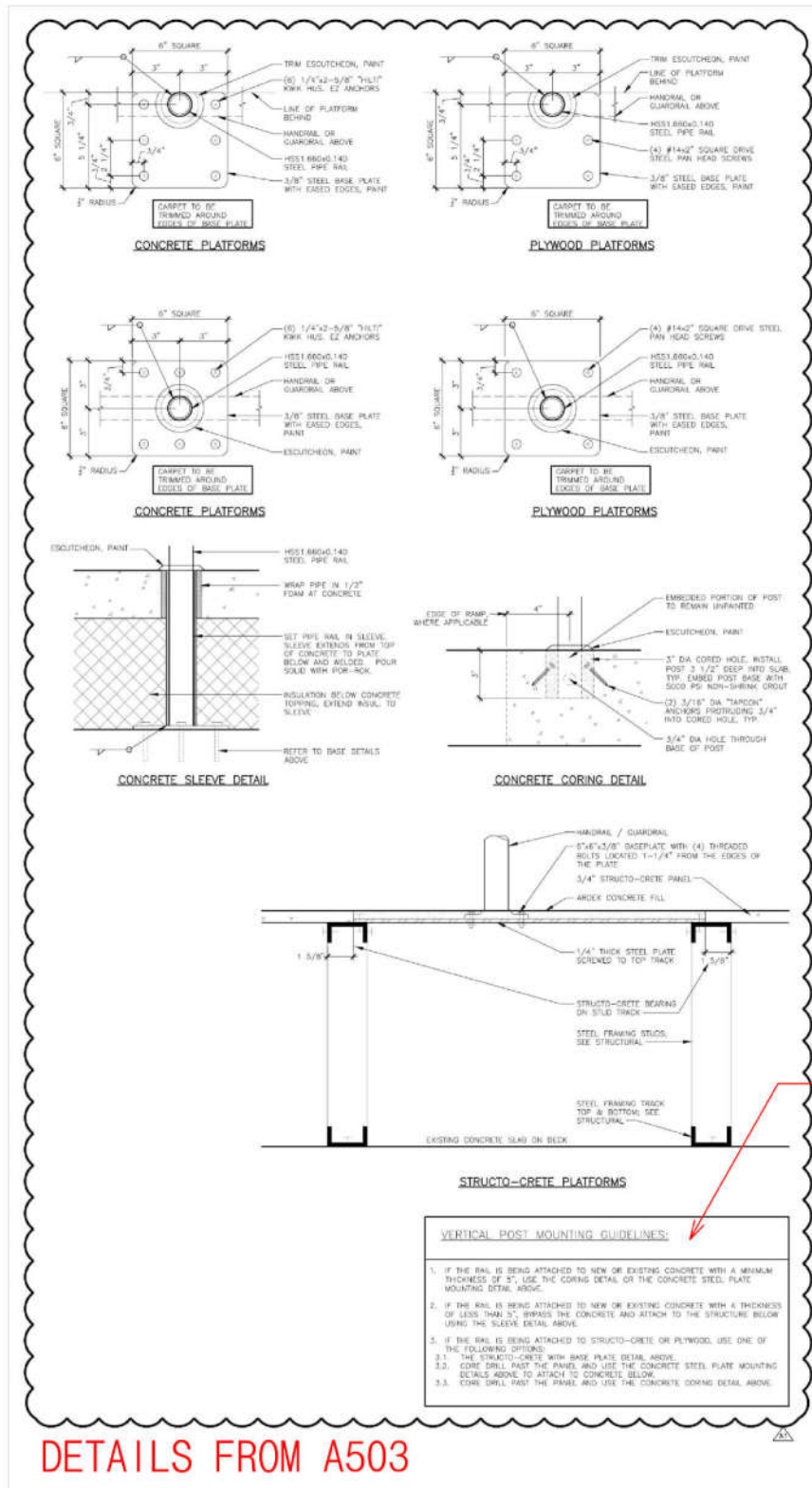

1. We would like you to consider not requiring escutcheons on top of the 6x6" baseplates. I've included a photo of a previous installation like this. I don't happen to think that this is an aesthetically pleasing look. Also, since the escutcheons are not attached, and move freely, they have the potential to get kicked and likely scratch the paint on the post. We're still happy to put them on if you require it.
2. If we go with the escutcheons on top of the baseplates, I would like to propose that we move the post farther away from the edge of the baseplate in order to make room for the entire escutcheon. If you look at the long guardrail in the same photo, you will see that, despite the fact that this particular railing did not have baseplates, you can still see that, because of the plastic lighted nosing, there is still plenty of room for the entire escutcheon, without the need to trim them. Also, if we do trim them, there is nothing to stop them from spinning around.
3. Where the offset 6x6" baseplates attach to a plywood floor, the detail shows all four screws on one side of the post. I would like to propose that we keep the screws in the corners. This way we only have to fabricate one kind of baseplate for the entire theater.
4. If the scenario arises that is described in #2 of the "Vertical Post Mounting Guidelines" from sheet A503, we will need to know as soon as you are aware that the situation is likely to arise. The logistics of this are not simple, and will require discussion and planning.
5. We would like to propose a change to the detail described by #3.1 of the "Vertical Post Mounting Guidelines" from sheet A503. The primary reason for proposing a change is that method described in #3.1 is that it is logistically difficult. As it stands, carpet can't be installed until after we install railings. We can't measure for railings until the Structo-Crete is in place, and the window of time between the Structo-Crete being installed and the carpet being installed is too narrow. This will likely cause delays in the installation of carpet.

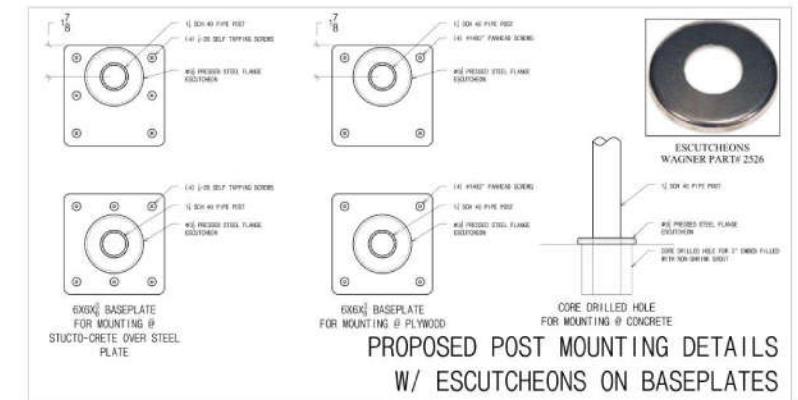
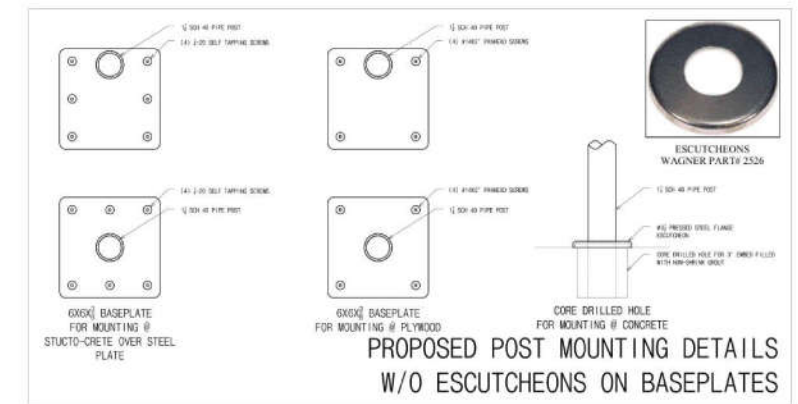
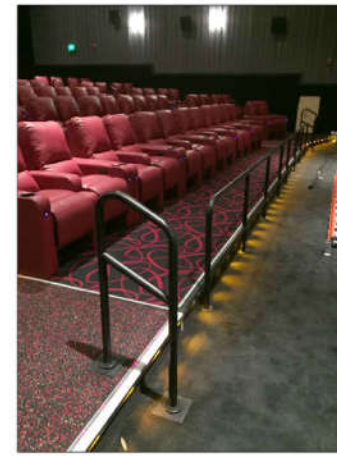

VERTICAL POST MOUNTING GUIDLINES

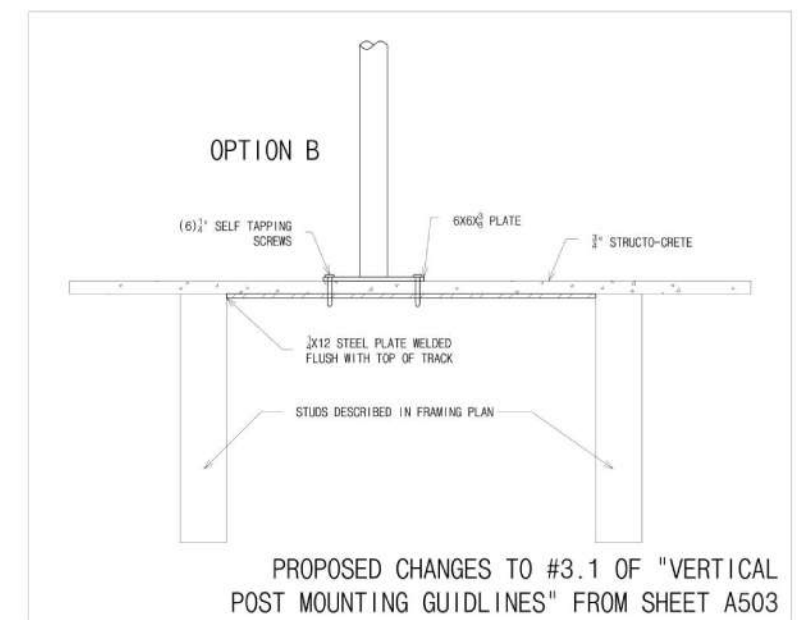
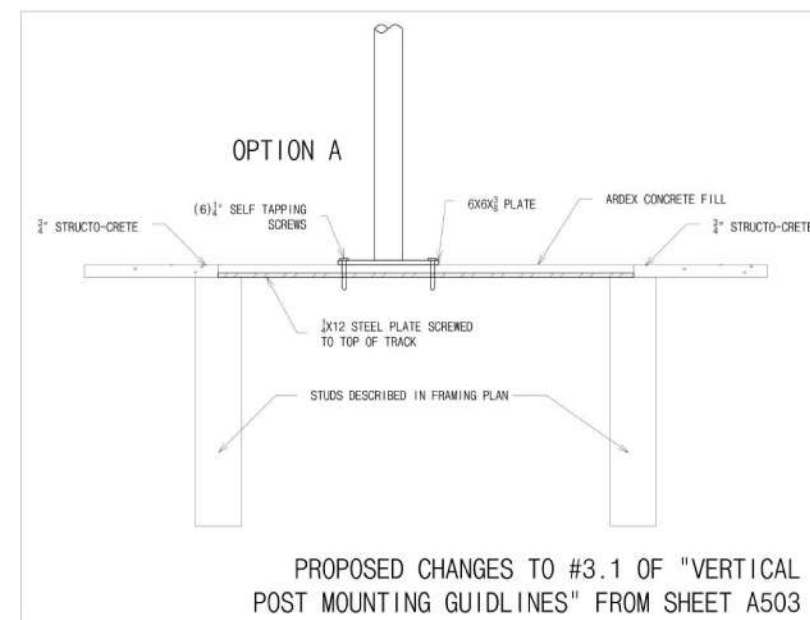

DRAWN: EY.
DATE: 3/17/16
REV: 0

BenFab, Inc.
801 Carpenters Crossing, Suite 8, Folcroft, PA 19032
Phone: 610-626-9100 Fax: 610-626-9200
www.benfabbrailings.com

AMC Georgetown
PROPOSED CHANGES

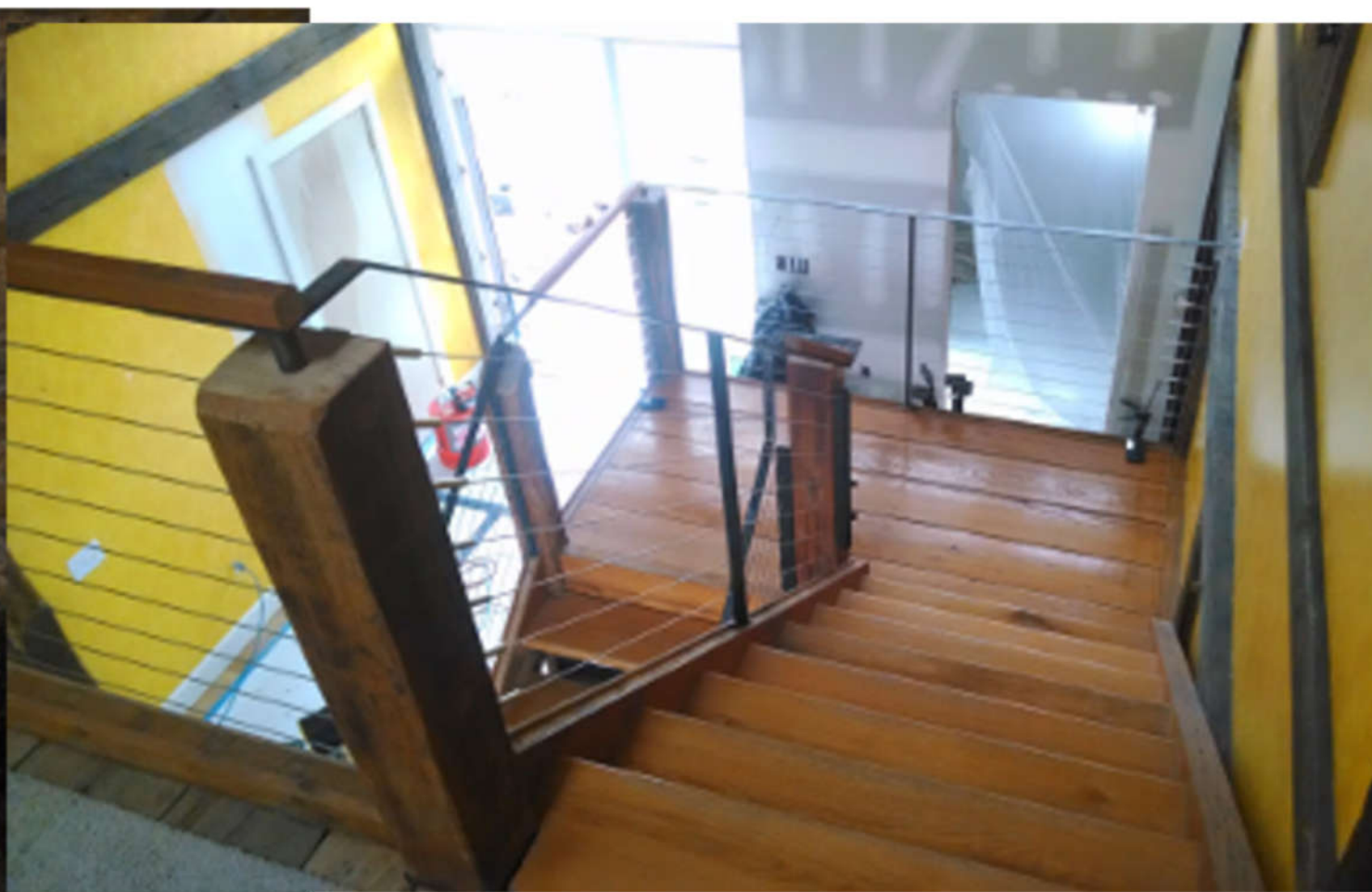

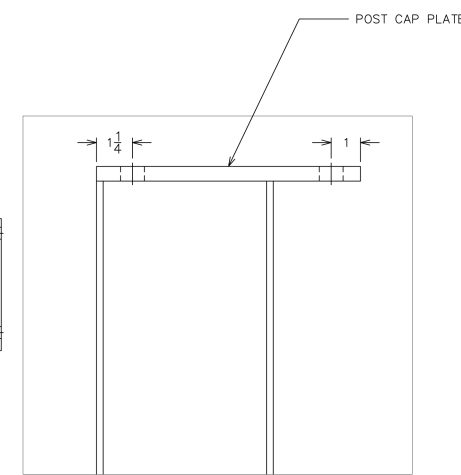
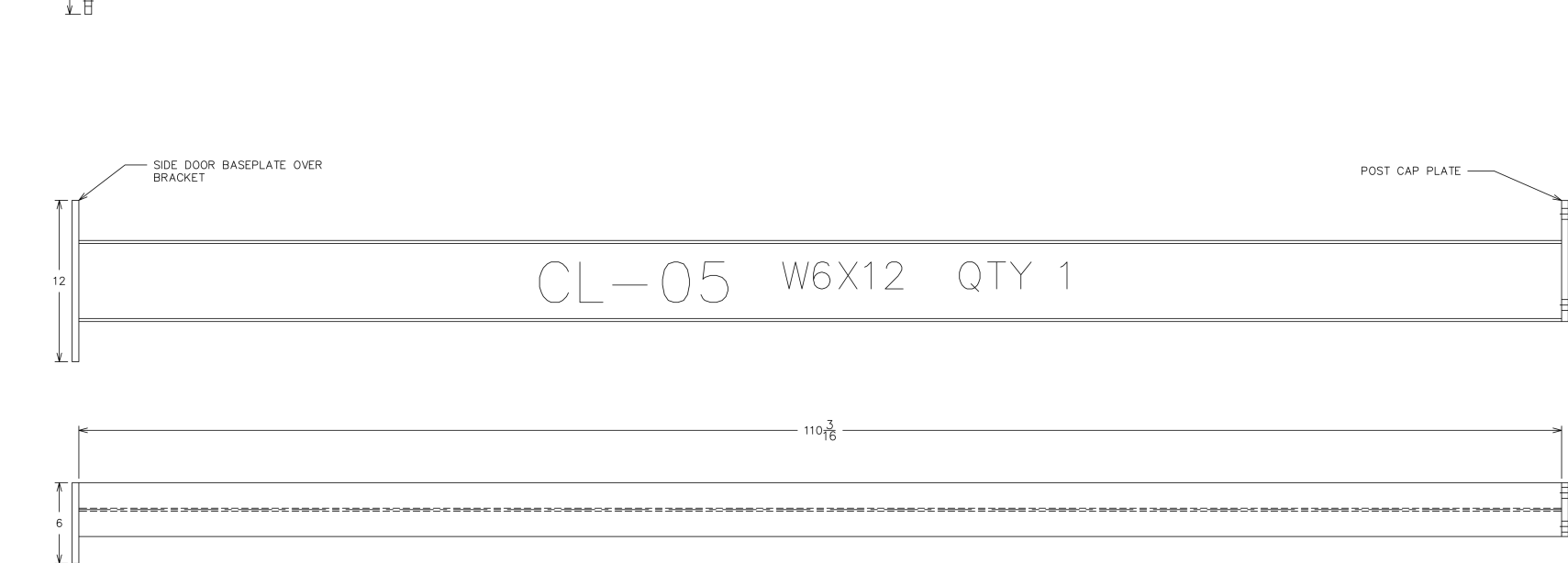
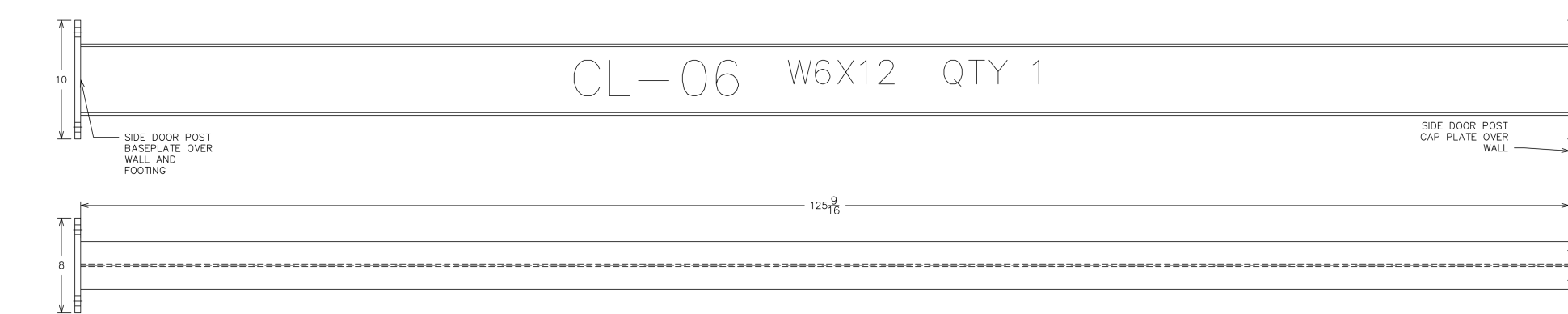
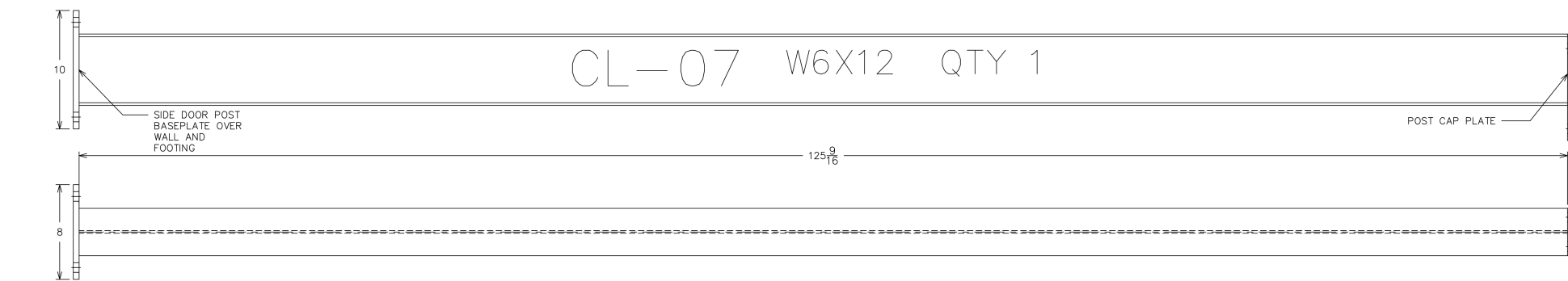
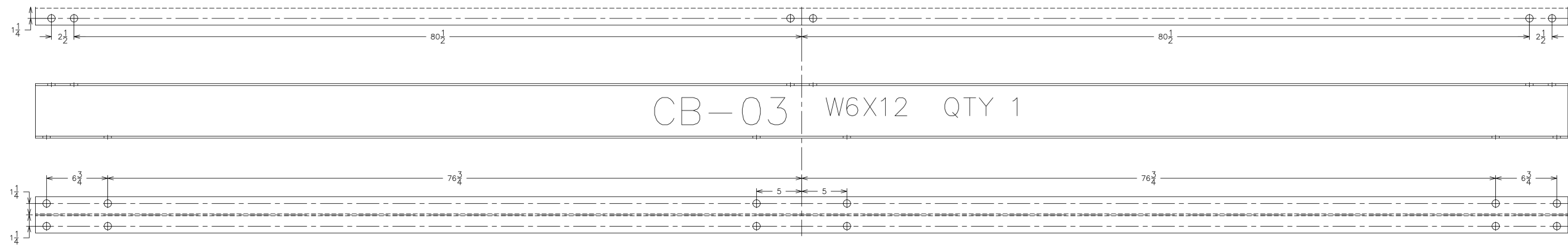

Column Top Detail

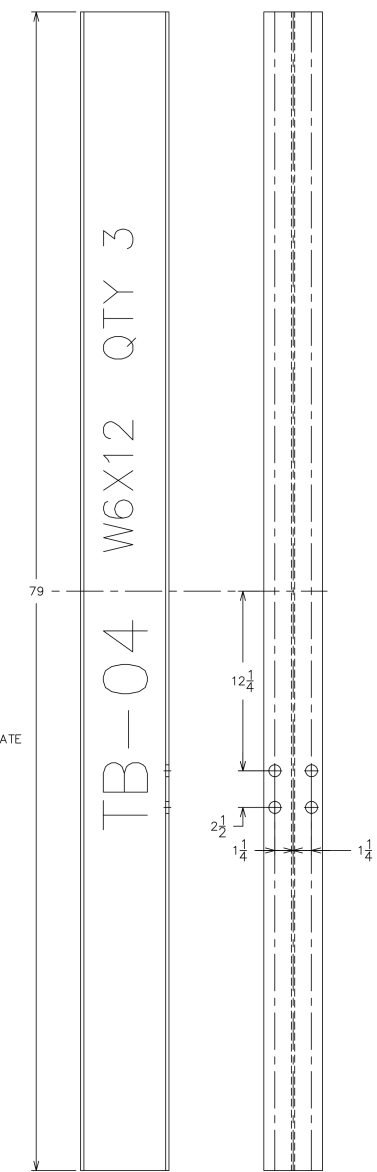

SIDE DOOR

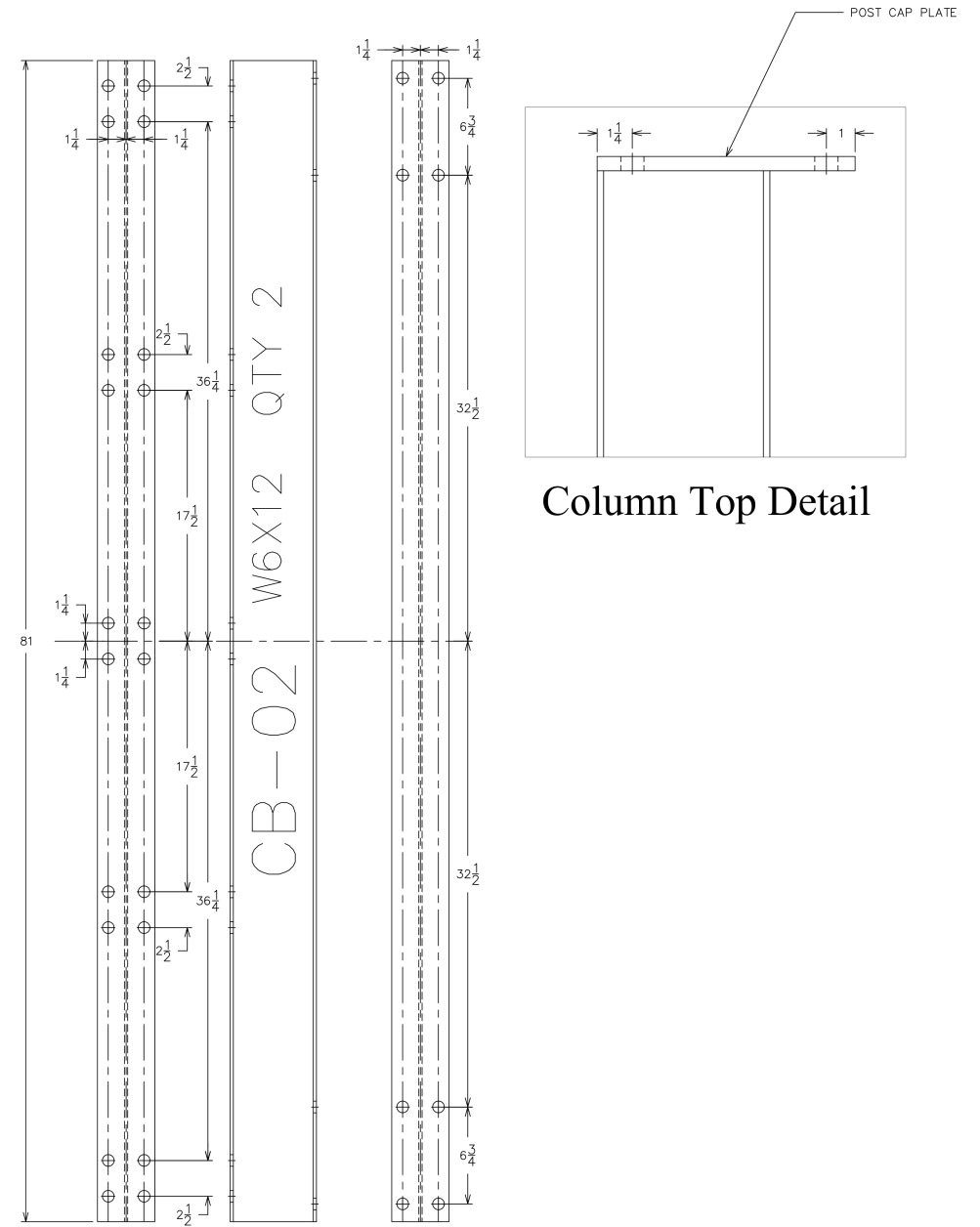
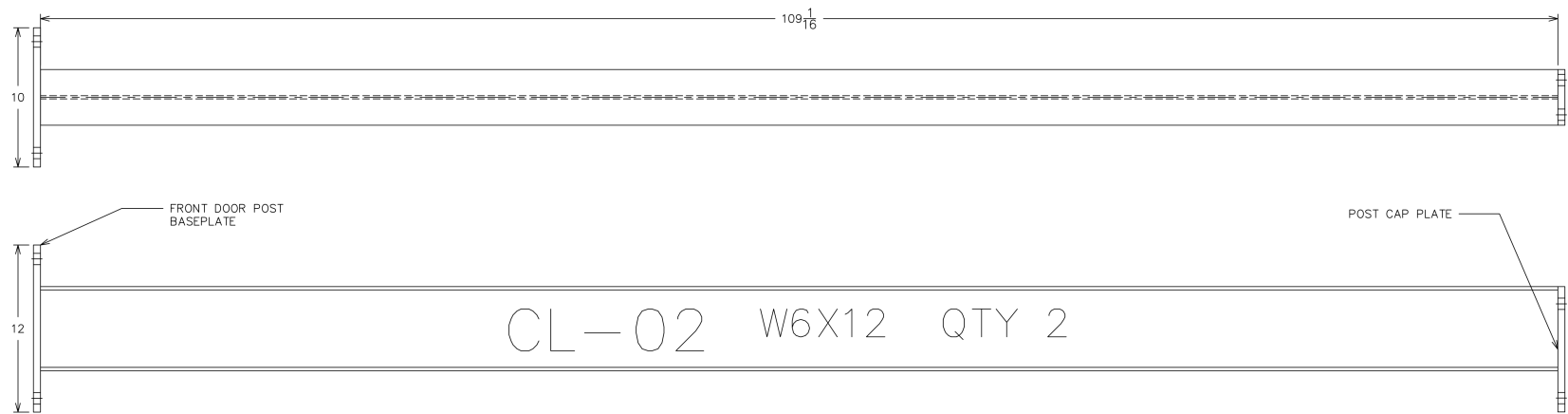
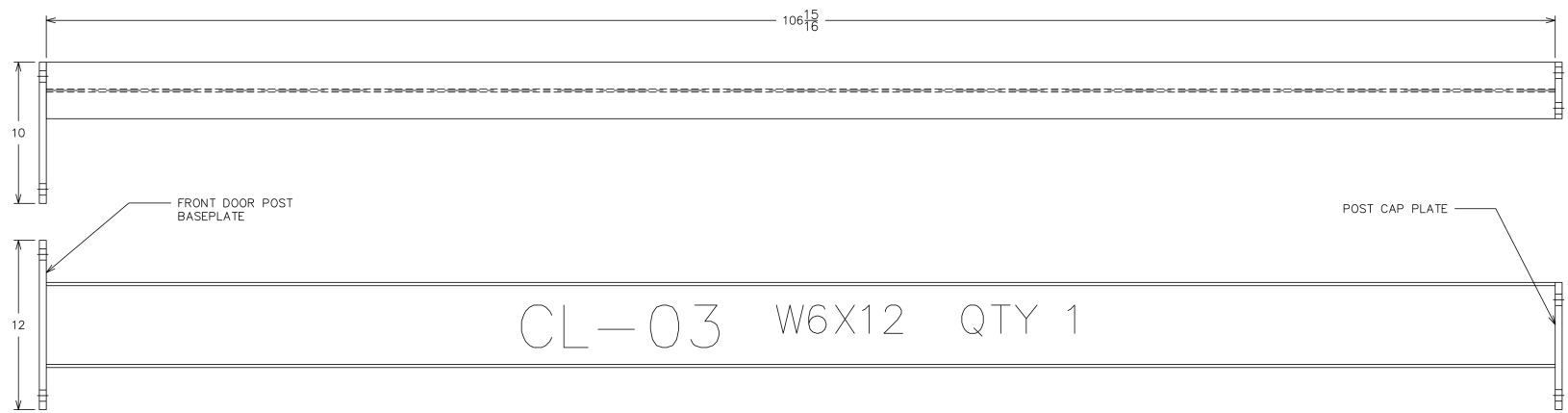
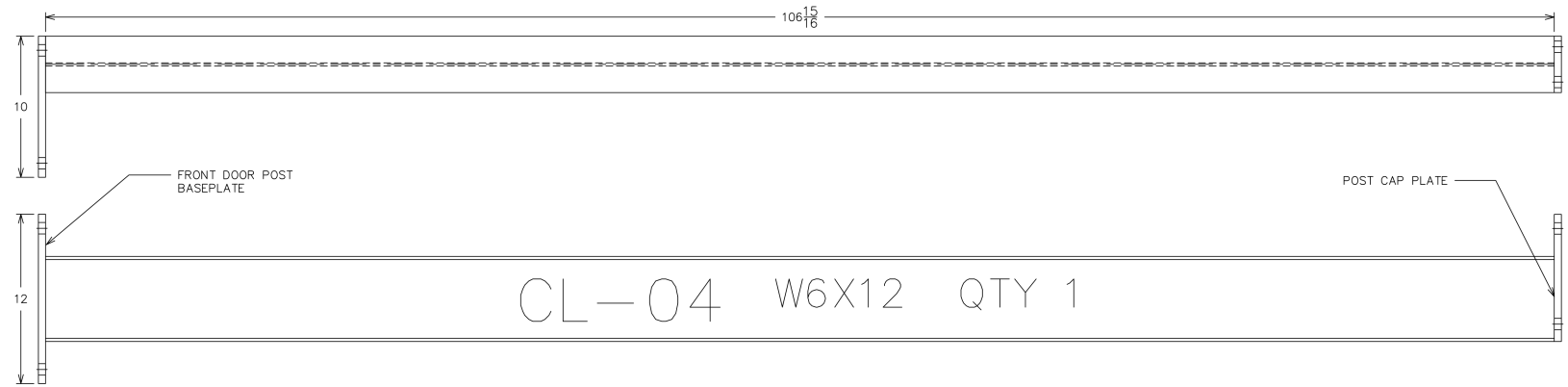
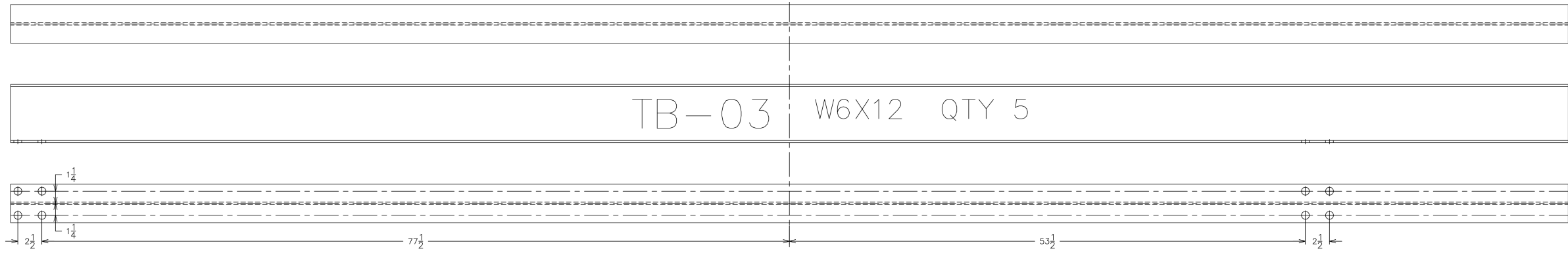

FRONT DOOR

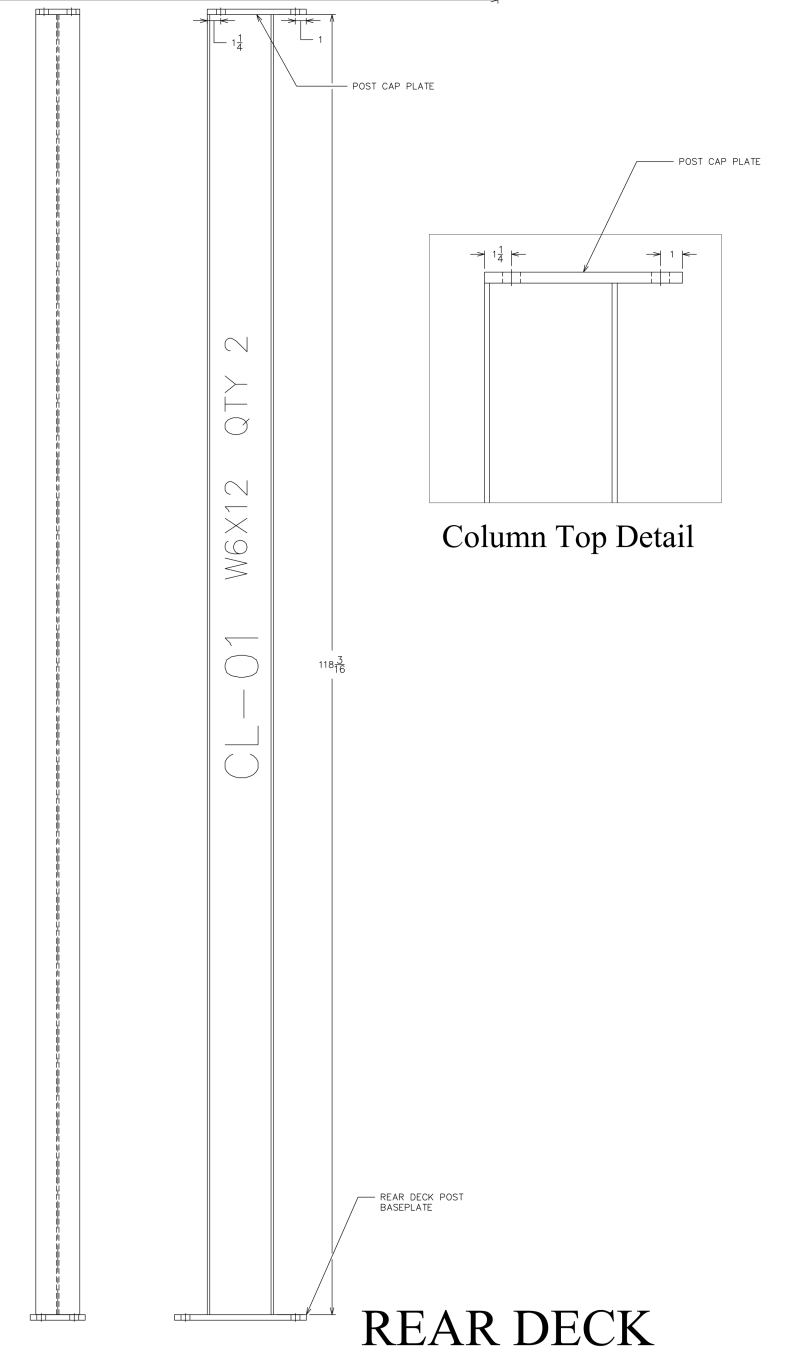
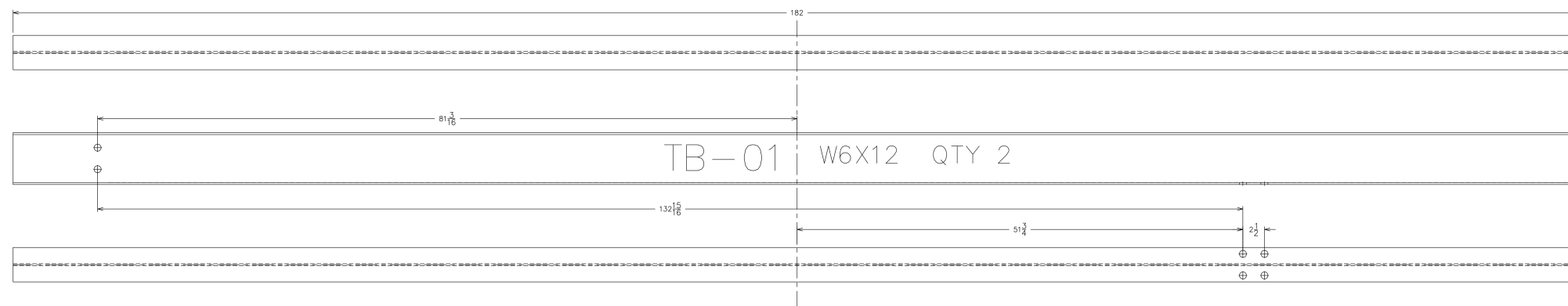
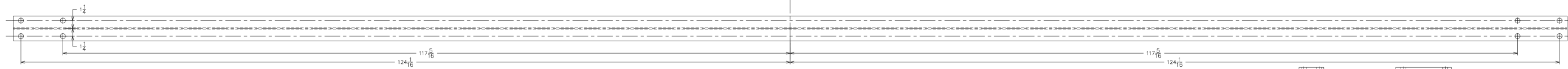
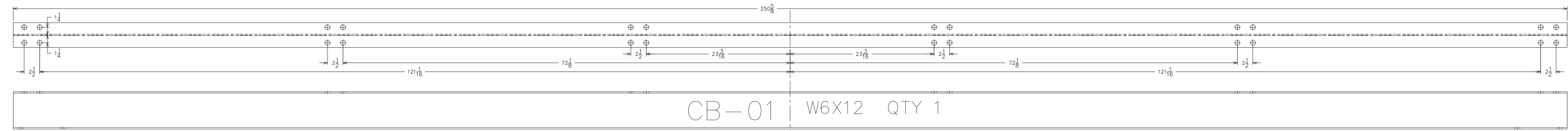
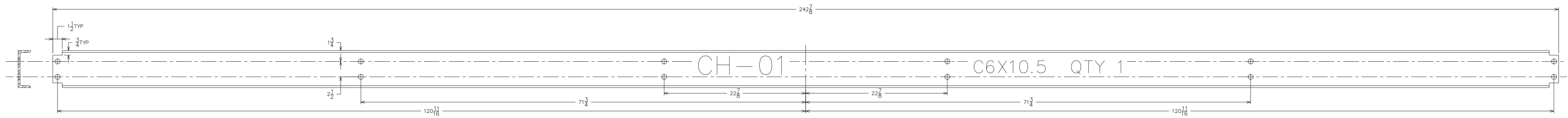

REAR DECK

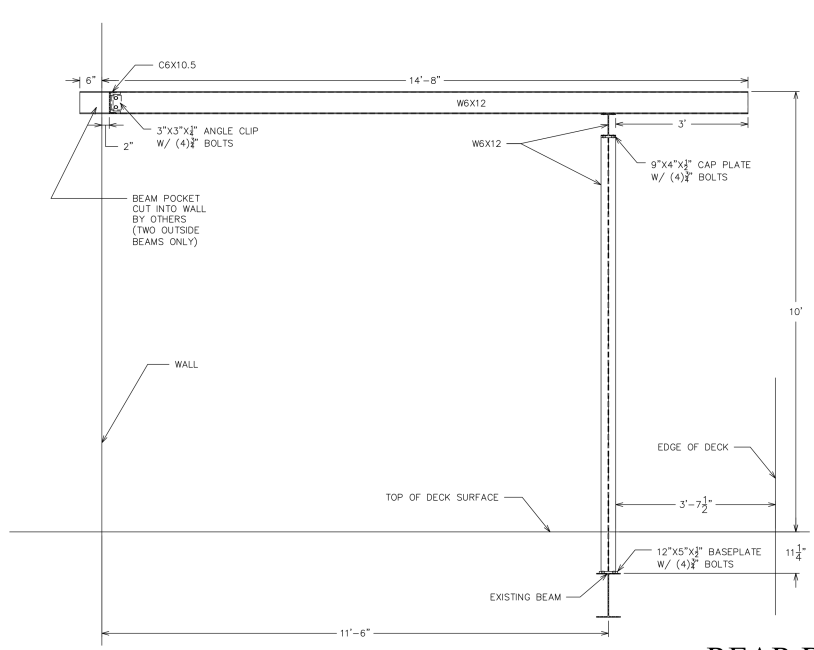

REAR DECK
SCALE 1/2"=1'

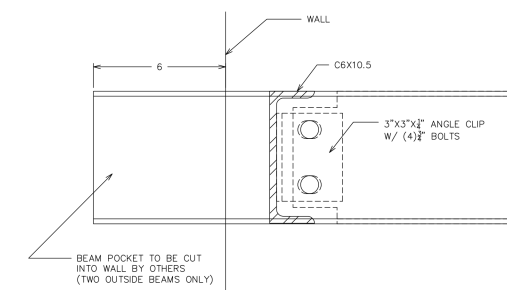
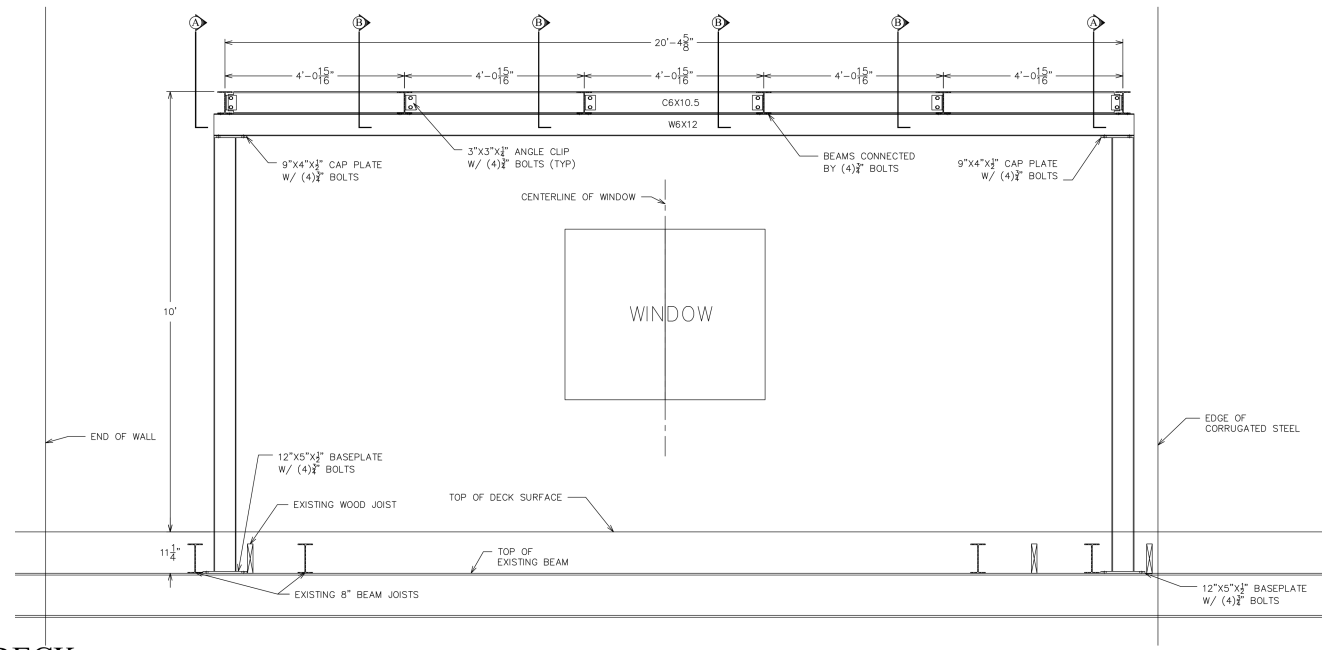

SECTION A
SCALE 3"=1'

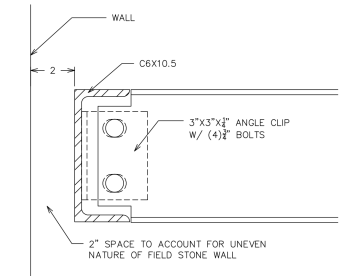

SECTION B
SCALE 3"=1'

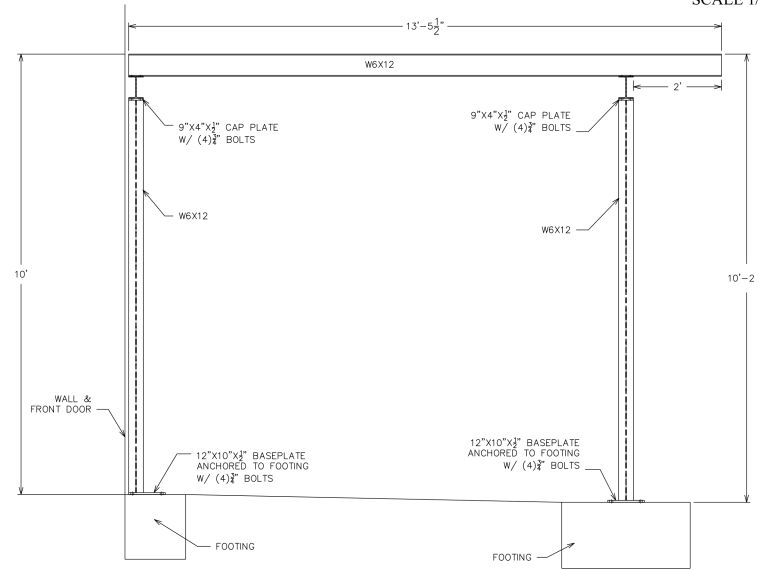

FRONT DOOR
SCALE 1/2"=1'

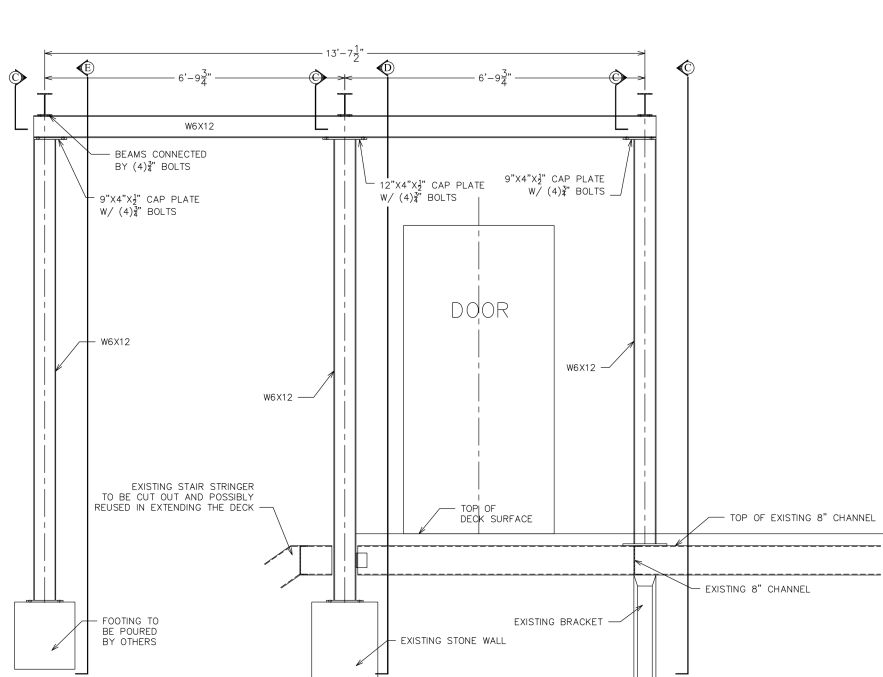
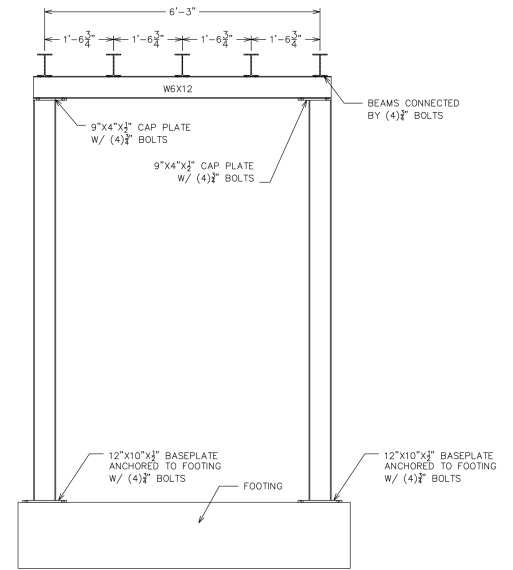

SIDE DOOR
SCALE 1/2"=1'

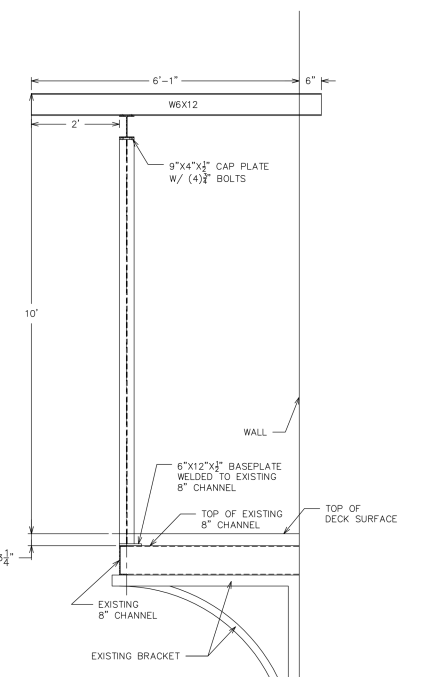

SECTION C
SCALE 1/2"=1'

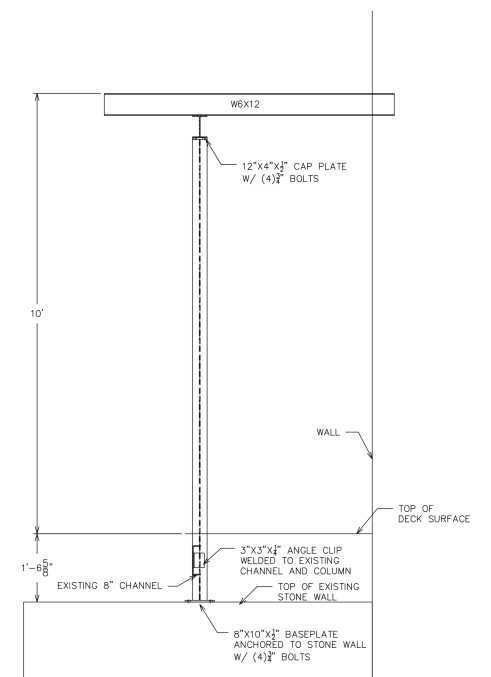

SECTION D
SCALE 1/2"=1'

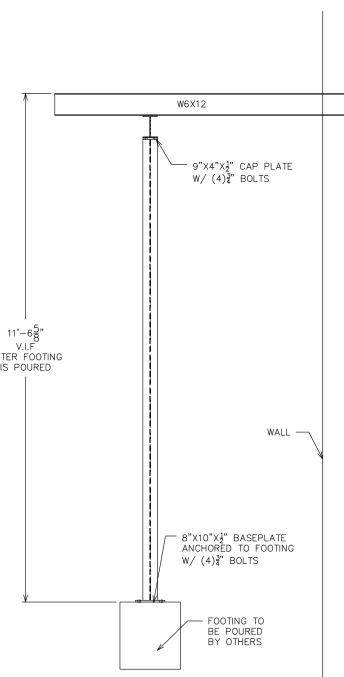

SECTION E
SCALE 1/2"=1'

Murray Residence

BenFab, Inc.
13 S. Highland Ave Lansdowne, PA 19050
Phone: 610-626-9100 Fax: 610-626-9200
www.benfabrailings.com

DRAWN: EY.
DATE: 4/3/14
REV: 0

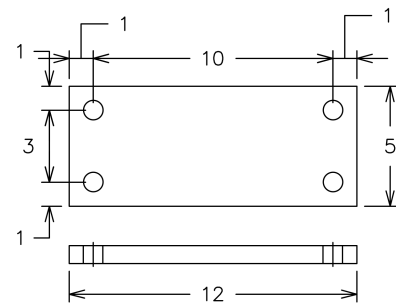

REAR DECK
POST BASEPLATES
QTY 2

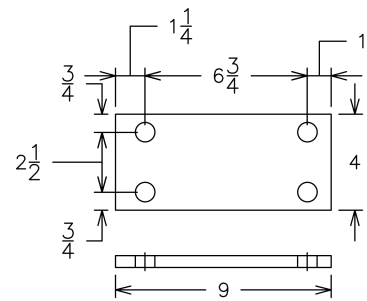

POST CAP PLATES
QTY 6

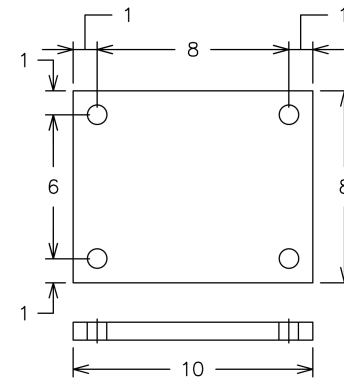

SIDE DOOR
POST BASEPLATE
OVER WALL & FOOTING
QTY 2

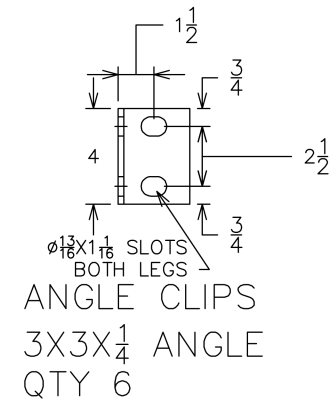

ANGLE CLIPS
3X3X $\frac{1}{4}$ ANGLE
QTY 6

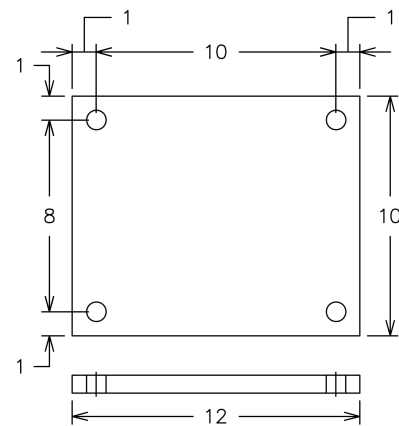

FRONT DOOR
POST BASEPLATES
QTY 4

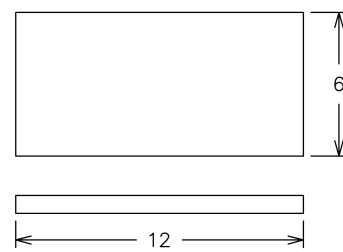

SIDE DOOR
POST BASEPLATE
OVER BRACKET
QTY 1

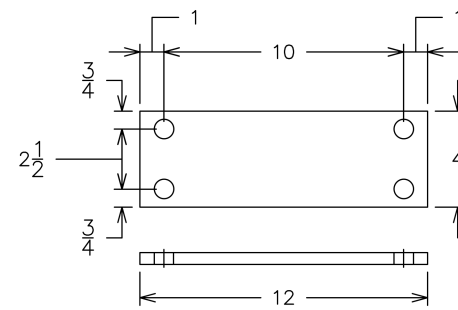

SIDE DOOR
POST CAP PLATE
OVER WALL
QTY 1

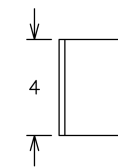

ANGLE CLIPS
3X3X $\frac{1}{4}$ ANGLE
QTY 2

MURRAY RESIDENCE PERGOLAS
COLUMN BASEPLATES AND CAP PLATES
ALL PLATES ARE $\frac{1}{2}$ " THICK
ALL HOLES ARE $\phi\frac{13}{16}$ "

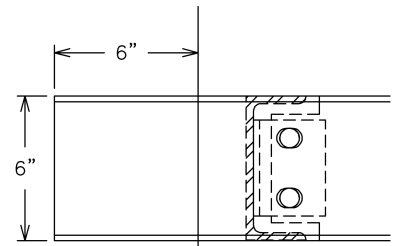

Section A
Scale 1 1/2"=1'

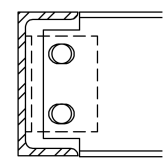

Section B
Scale 1 1/2"=1'

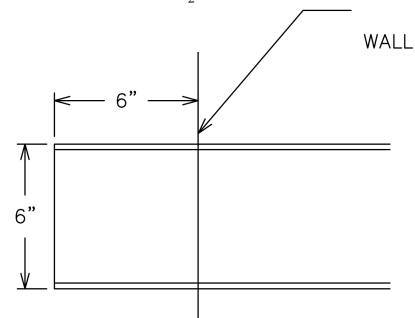

Section C
Scale 1 1/2"=1'

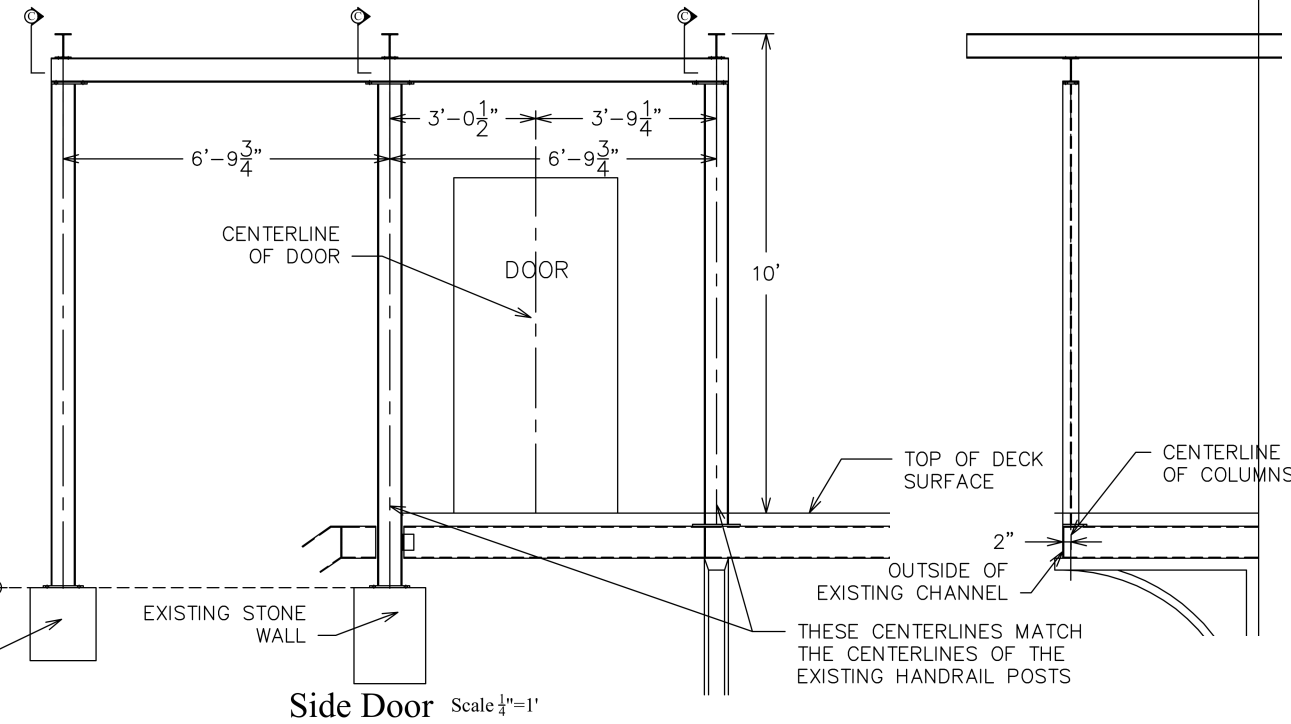
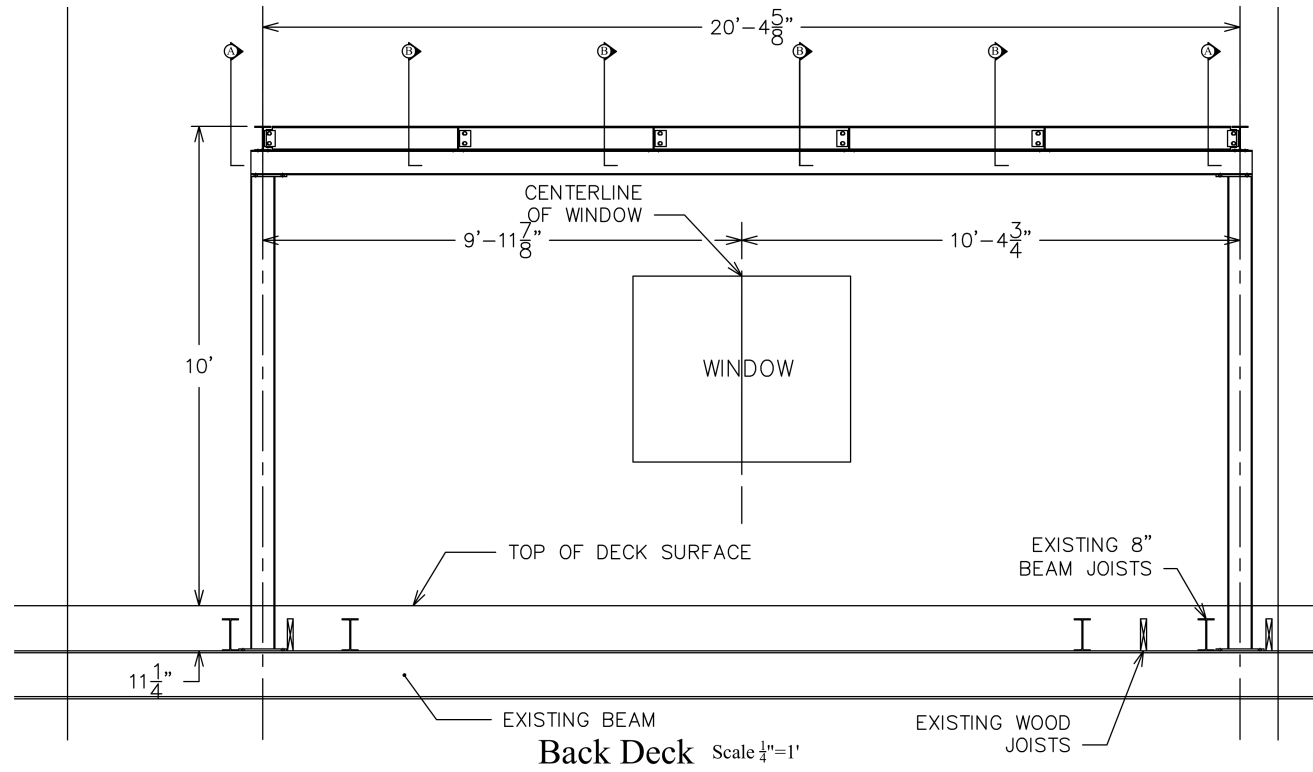
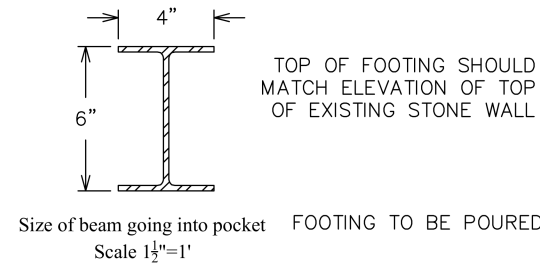

Murray Residence

BenFab, Inc.
13 S. Highland Ave Lansdowne, PA 19050
Phone: 610-626-9100 Fax: 610-626-9200
www.benfabrailings.com

DRAWN: EY.

DATE: 4/3/14

REV: 0

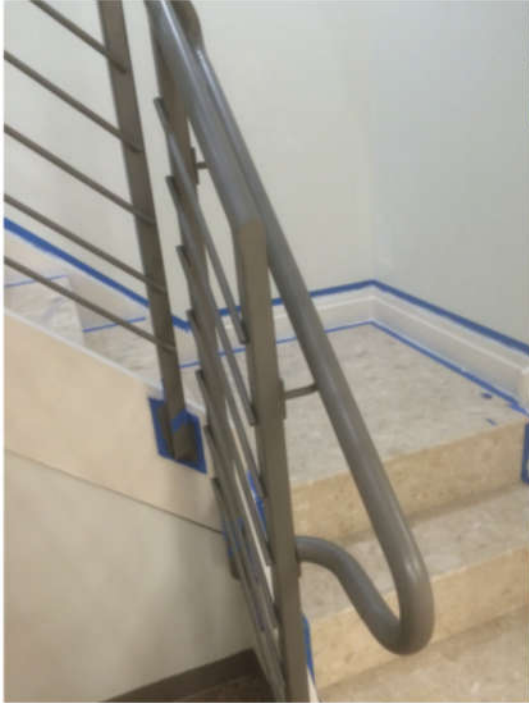
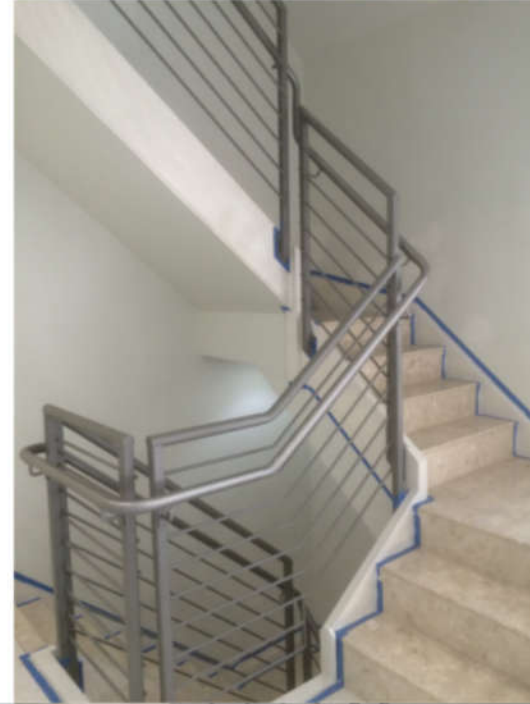

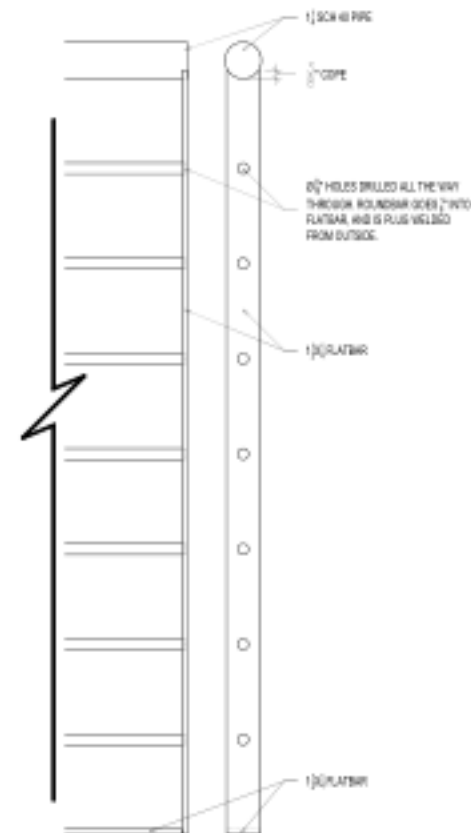
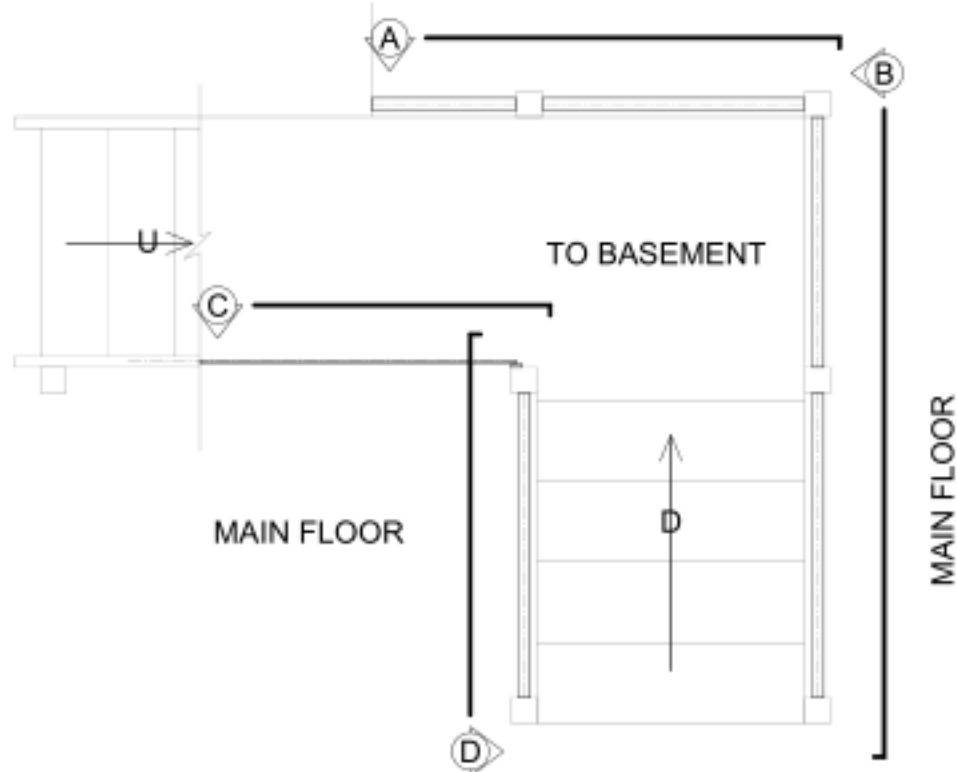
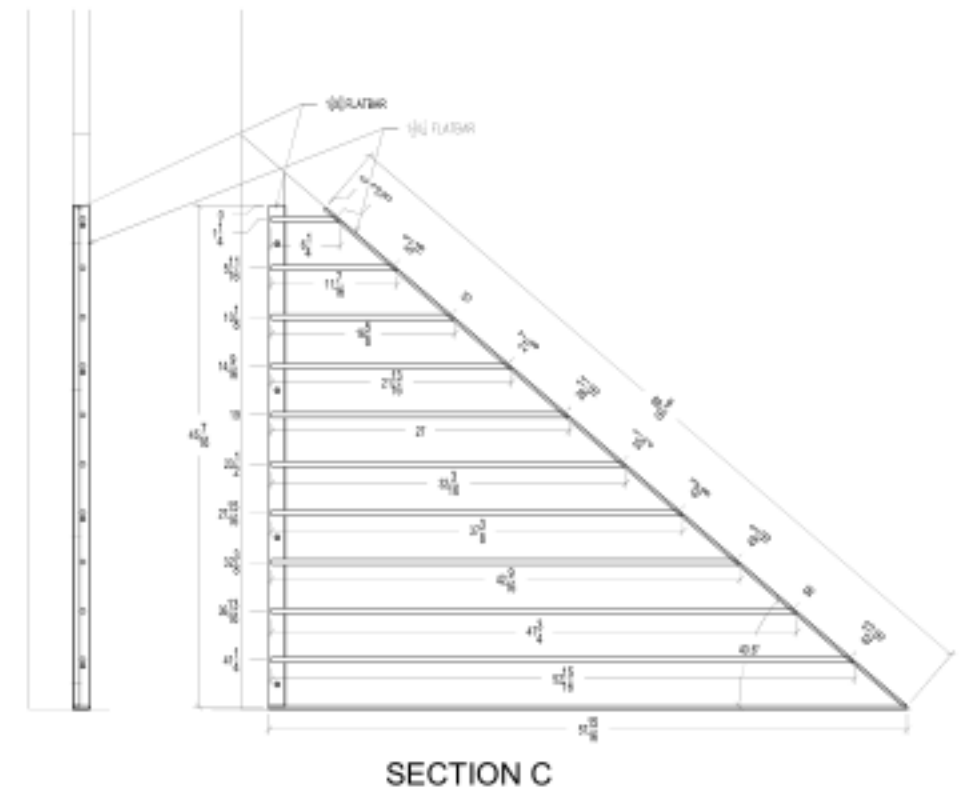
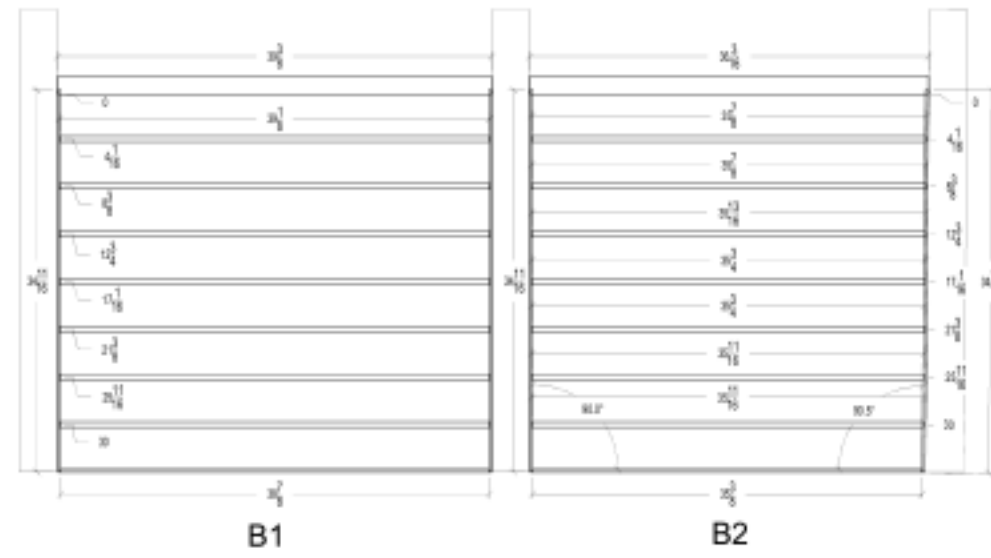
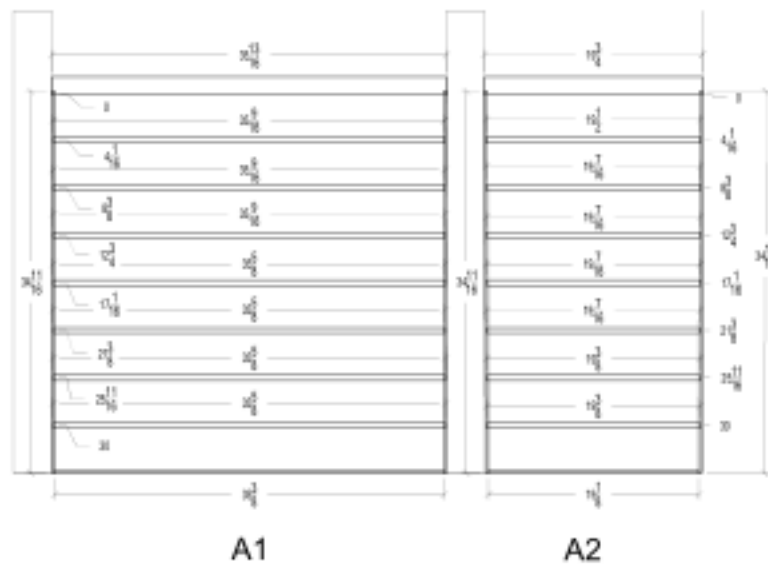

MATERIALS
 TOP RAIL
 SIDES AND BOTTOM
 PICKETS
 #14 F.H. SCREWS

1) SCH 40 PIPE
 1) 1/2" FLATBAR
 1) 1/2" ROUND BAR
 QTY ??



MAIN FLOOR

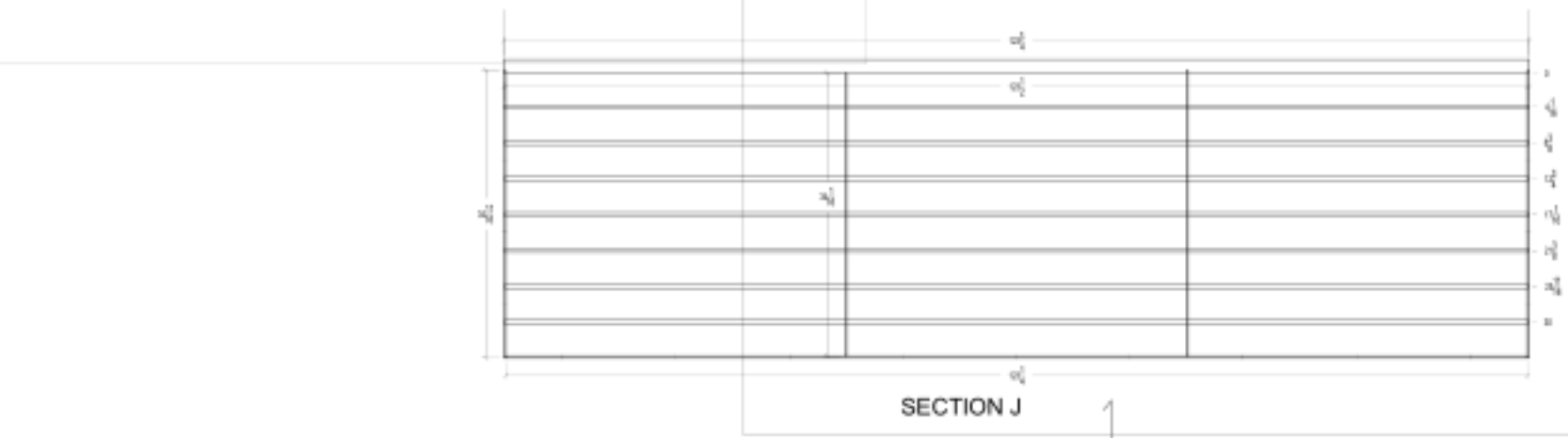
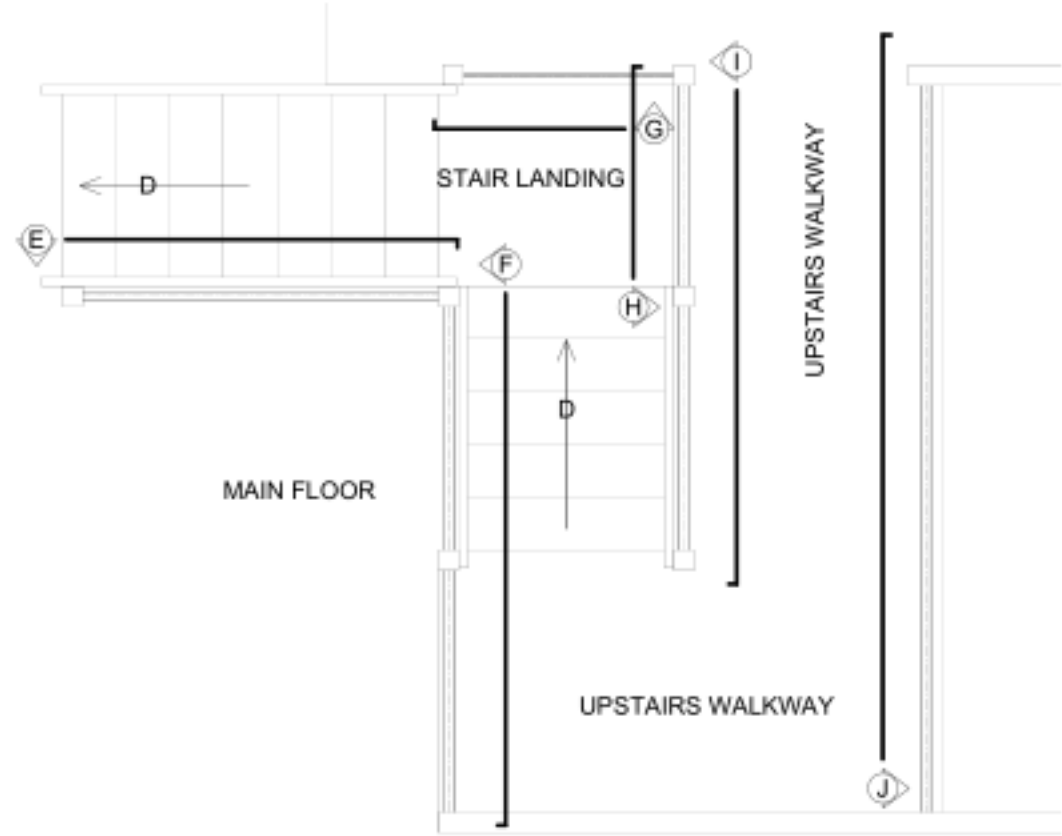
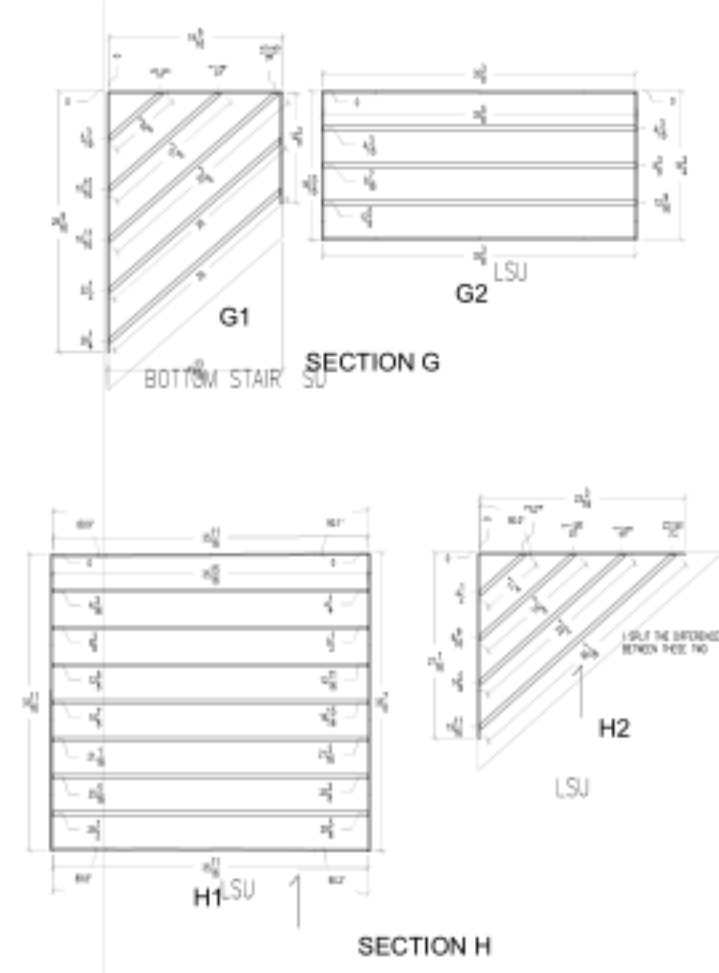
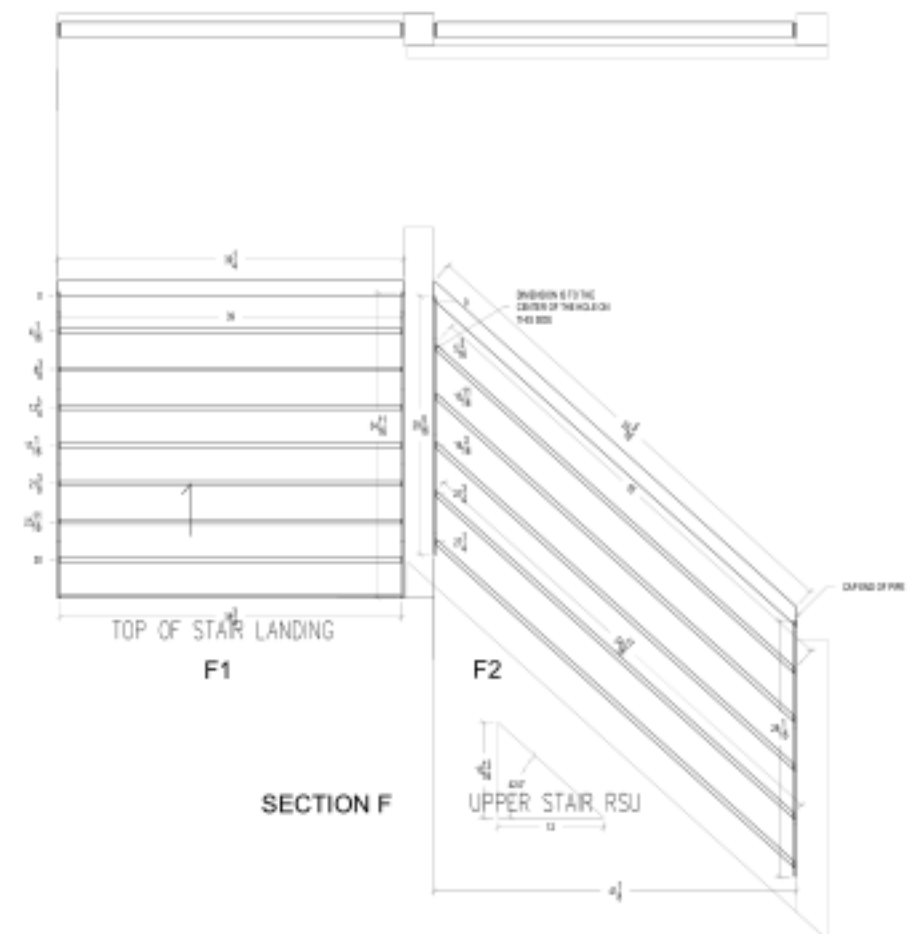
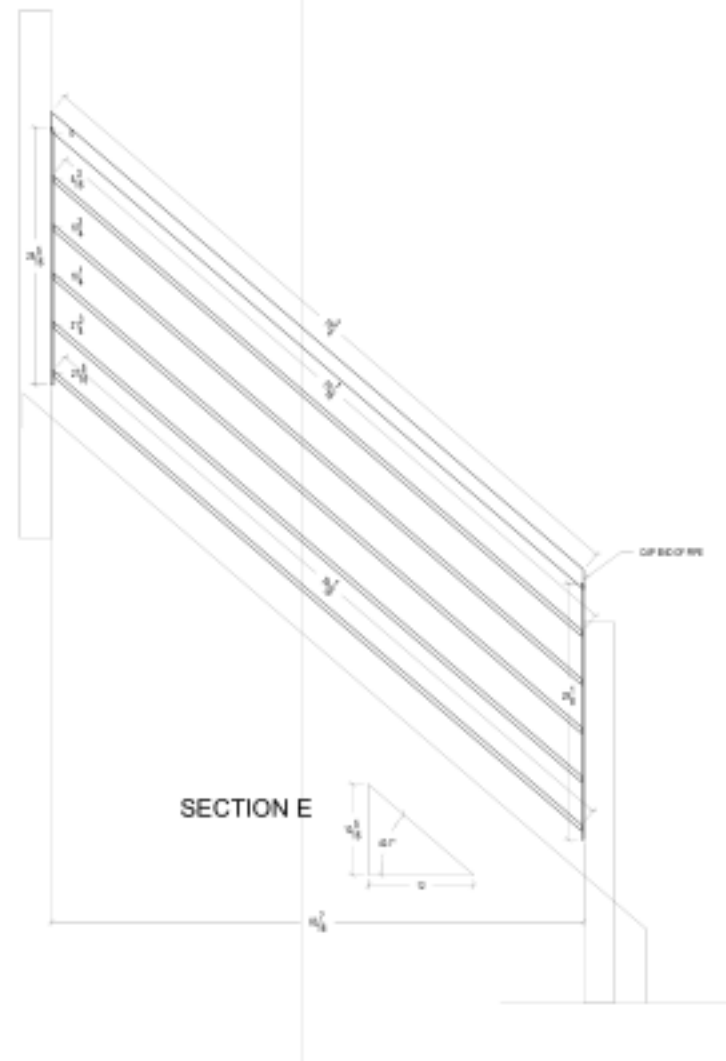

STAIRS & WALKWAY

Not sure how to do this, but DO NOT cut this corner off so that it doesn't stick up above the 1/4" section when installed

CONSIDERED FROM BOTTOM OF RAIL TO CENTER OF LAST PICKET (NOTE: NOT THE PICKET)

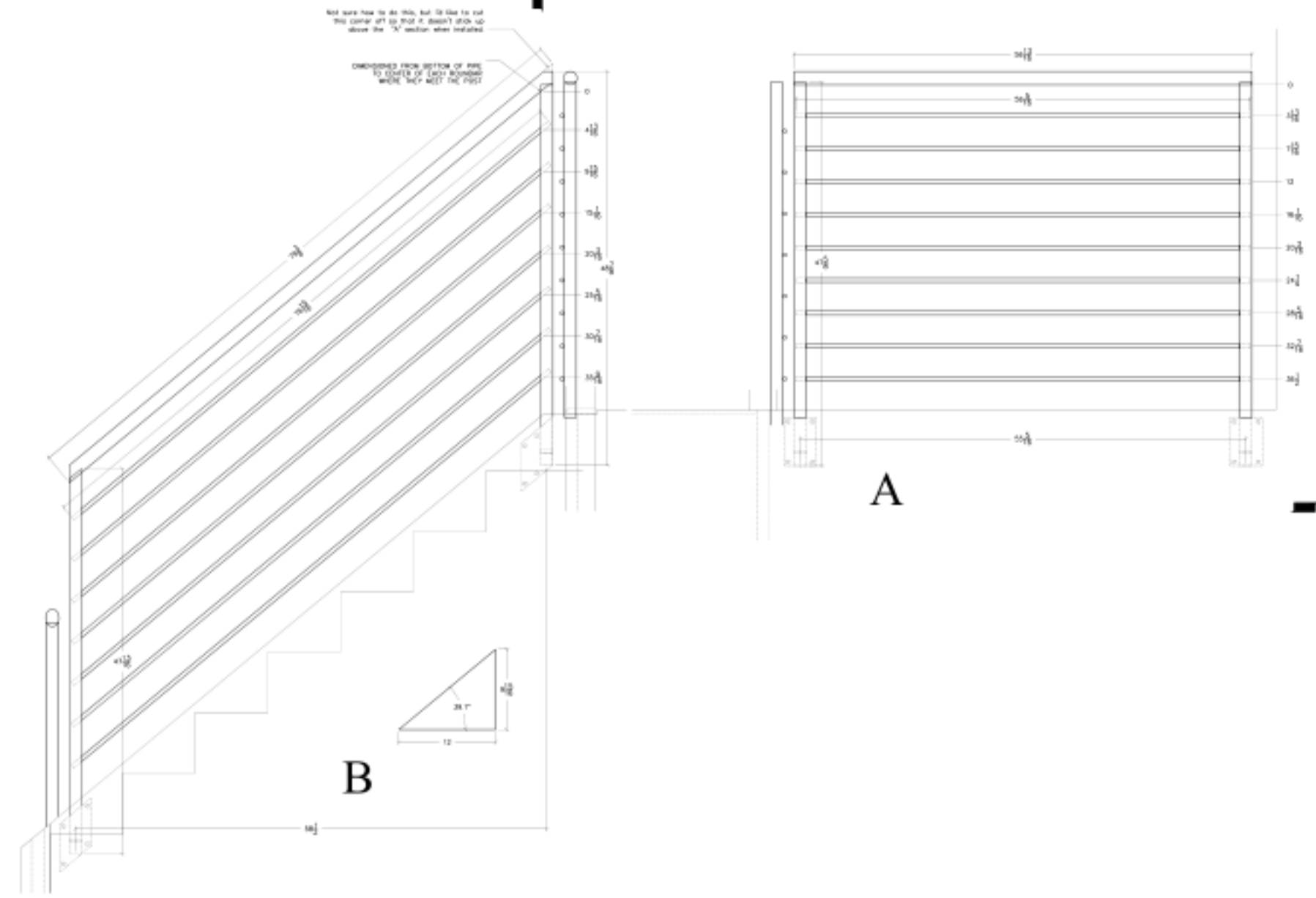

A

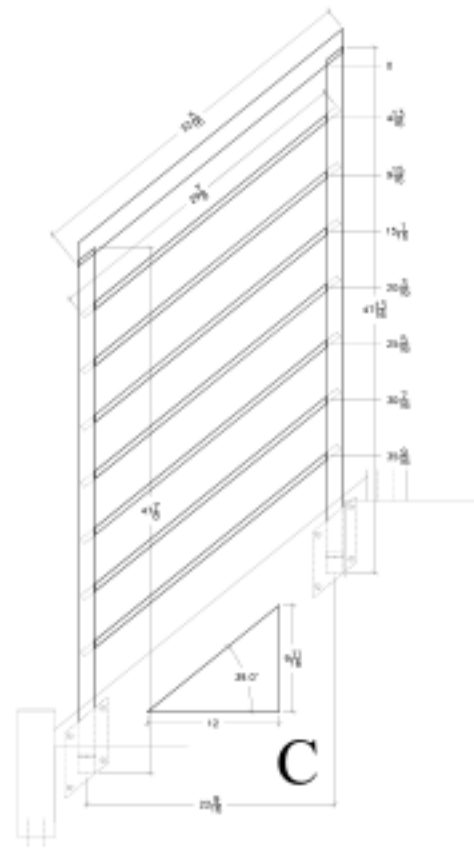
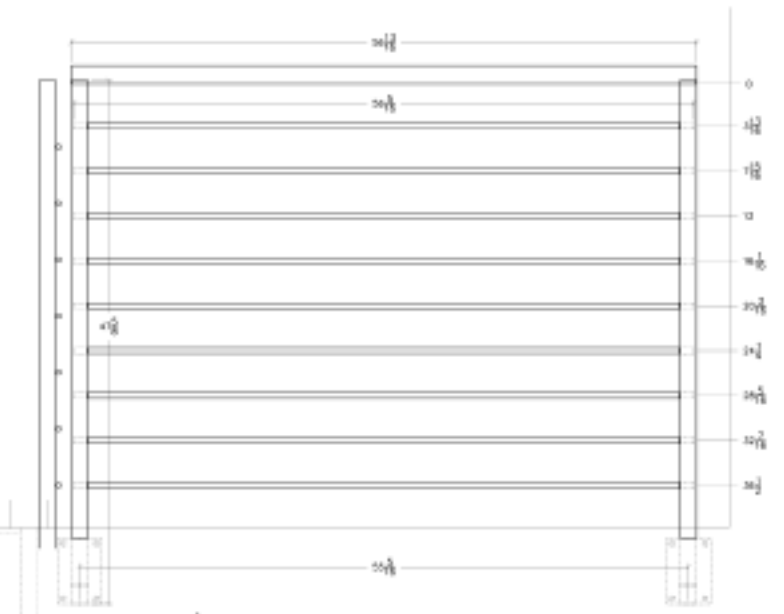

C

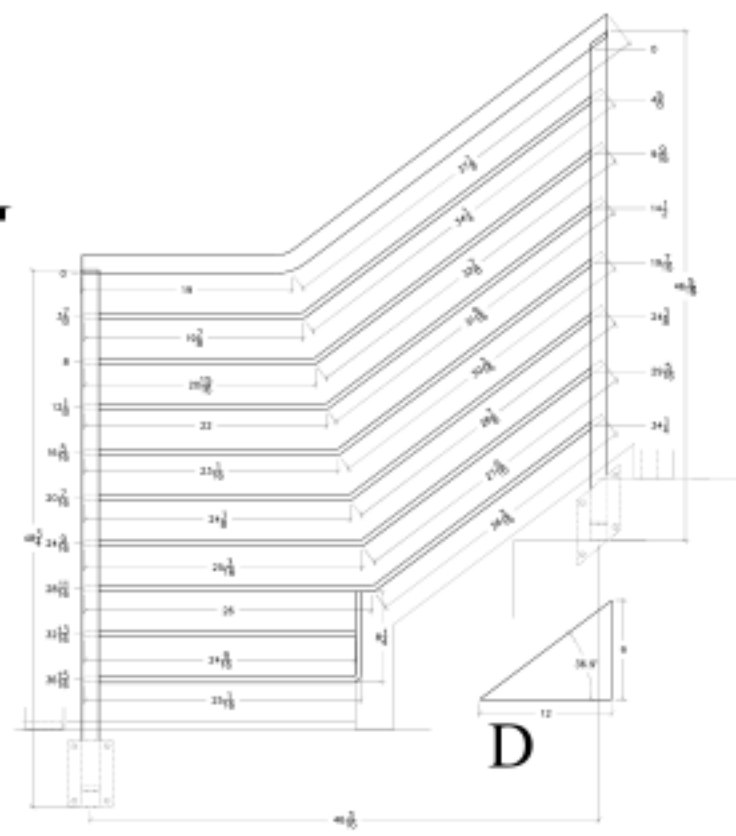
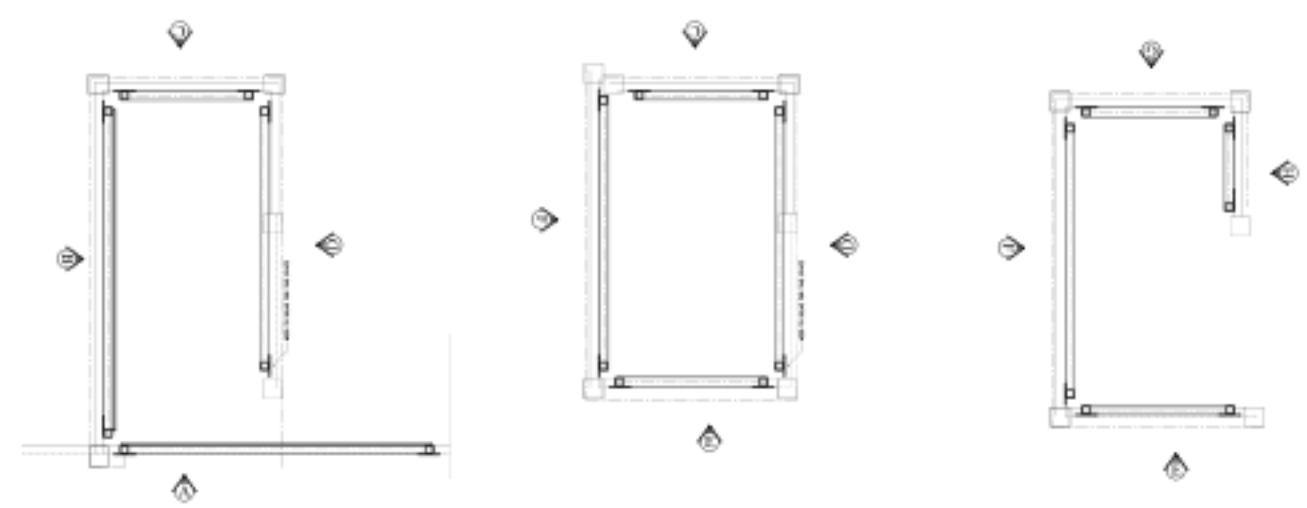

D

- MATERIALS:
- POSTS 1 1/2" SQ TUBE
 - GUARD TOP RAIL 1 1/2" SCH 40
 - HANDRAIL 1 1/2" SCH 40
 - PICKETS 1/2" ROUND BAR

GUARDRAILS A-D

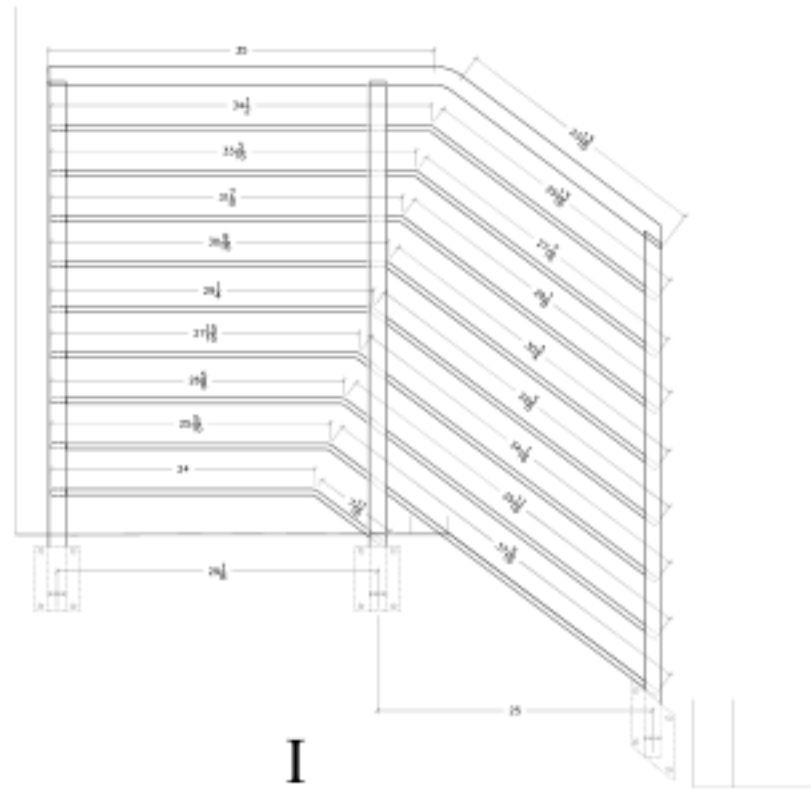

I

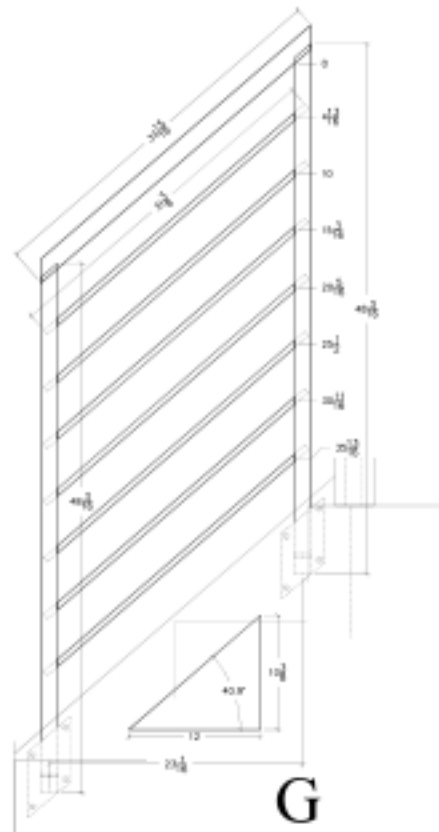

G

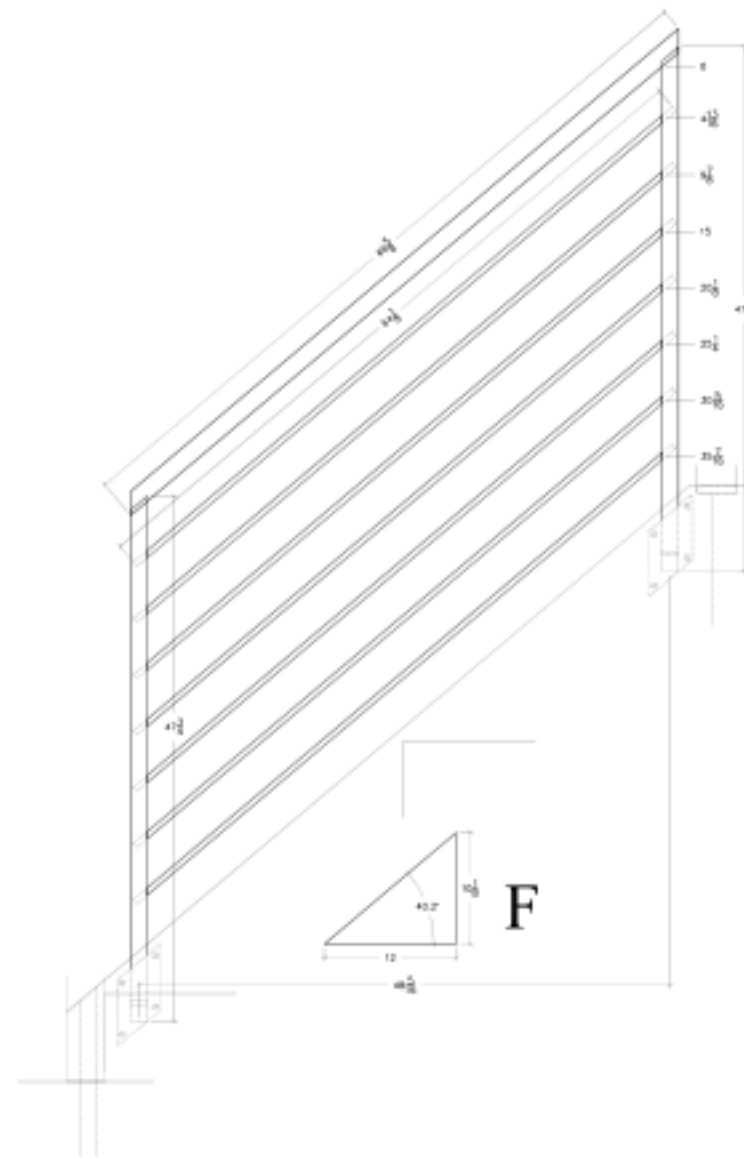

F

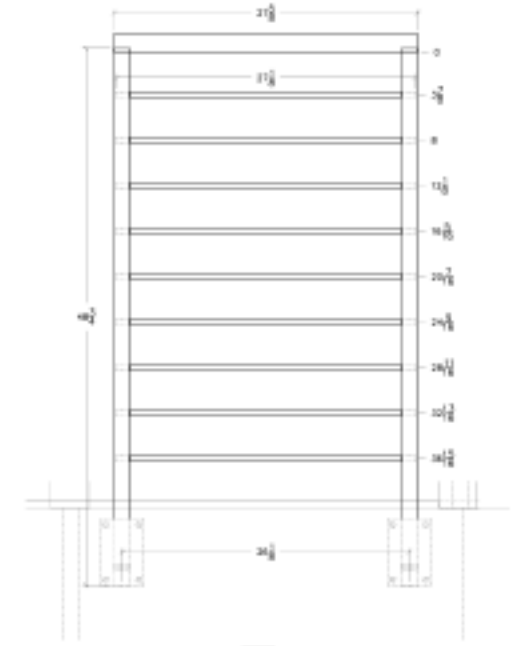

E

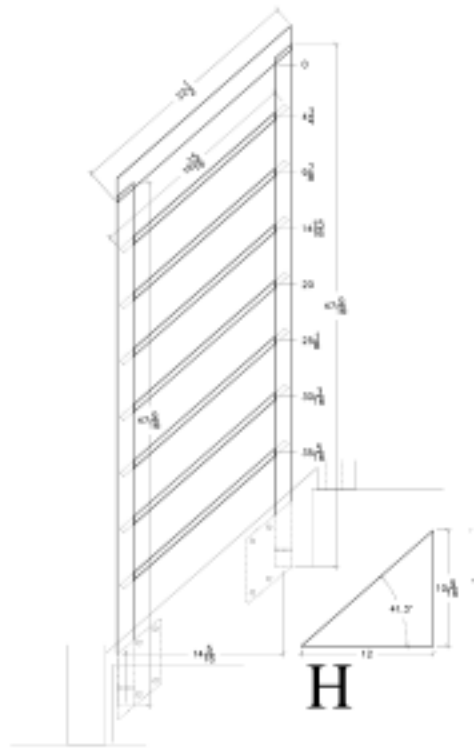

H

- MATERIALS:
- POSTS 1 1/2" SQ TUBE
 - GUARD TOP RAIL 1 1/2" SCH 40
 - HANDRAIL 1 1/2" SCH 40
 - PICKETS 1/2" ROUND BAR

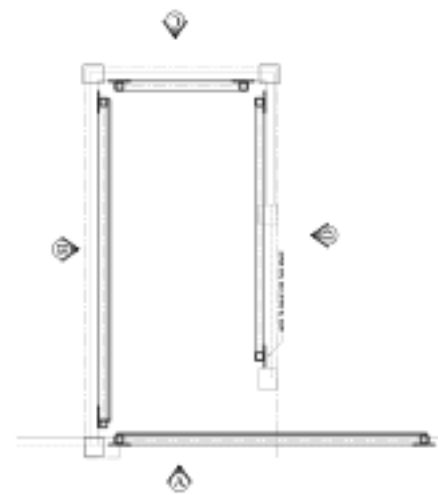

A

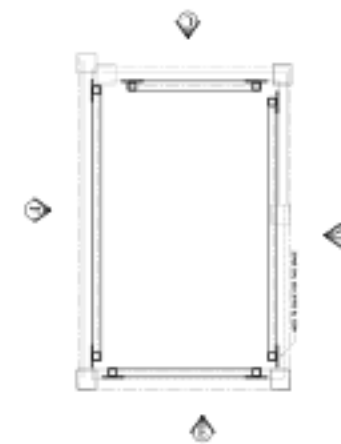

B

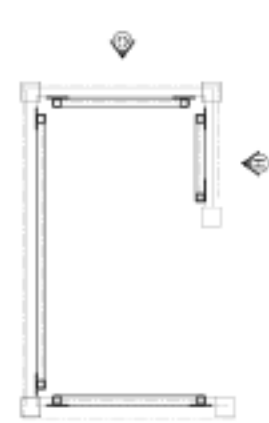

C

GUARDRAILS E-1

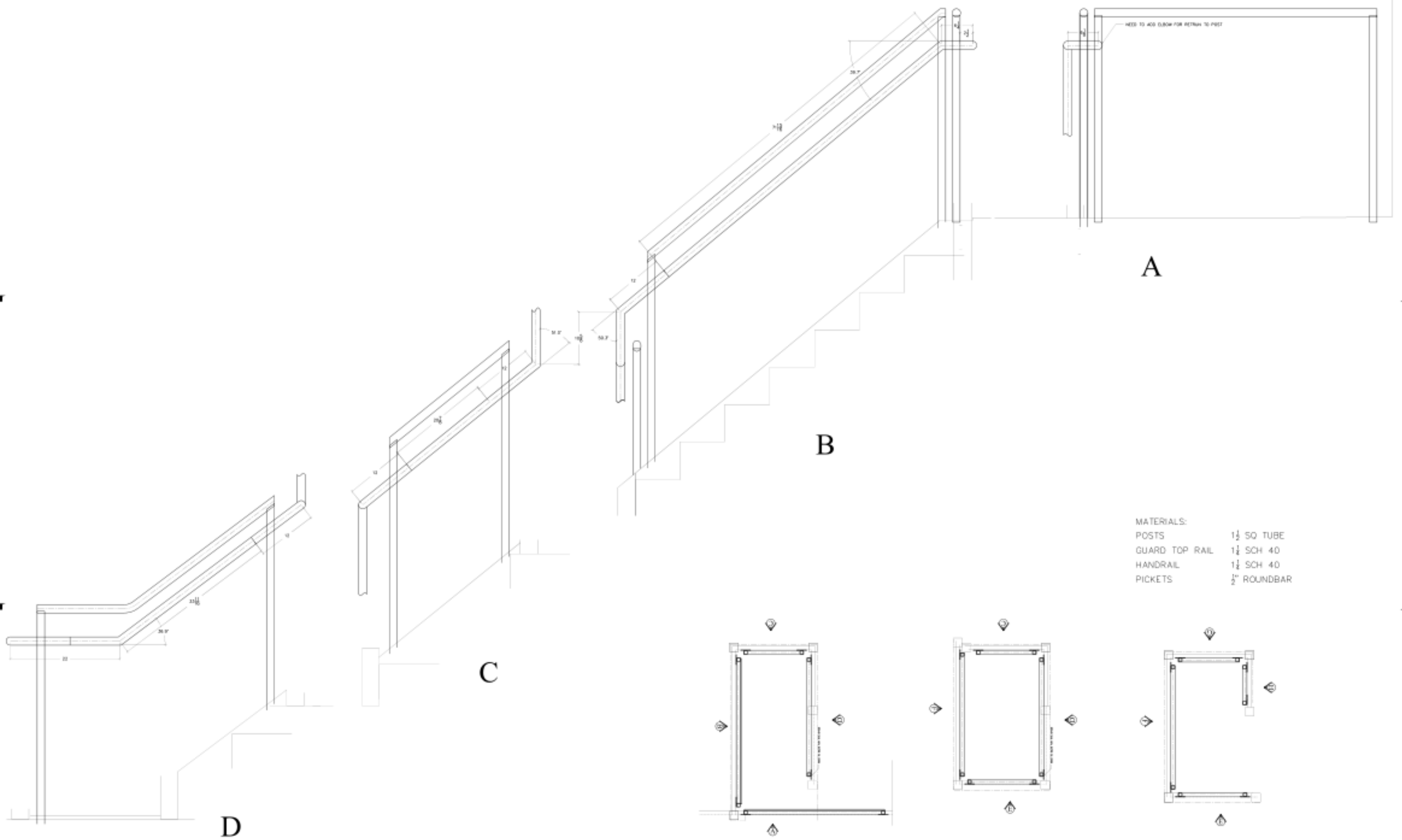

NEED TO ADD ELBOW FOR RETURN TO POST

A

B

C

D

- MATERIALS:
- POSTS 1 1/2 SQ TUBE
 - GUARD TOP RAIL 1 1/2 SCH 40
 - HANDRAIL 1 1/2 SCH 40
 - PICKETS 1/2" ROUND BAR

HANDRAILS A-D

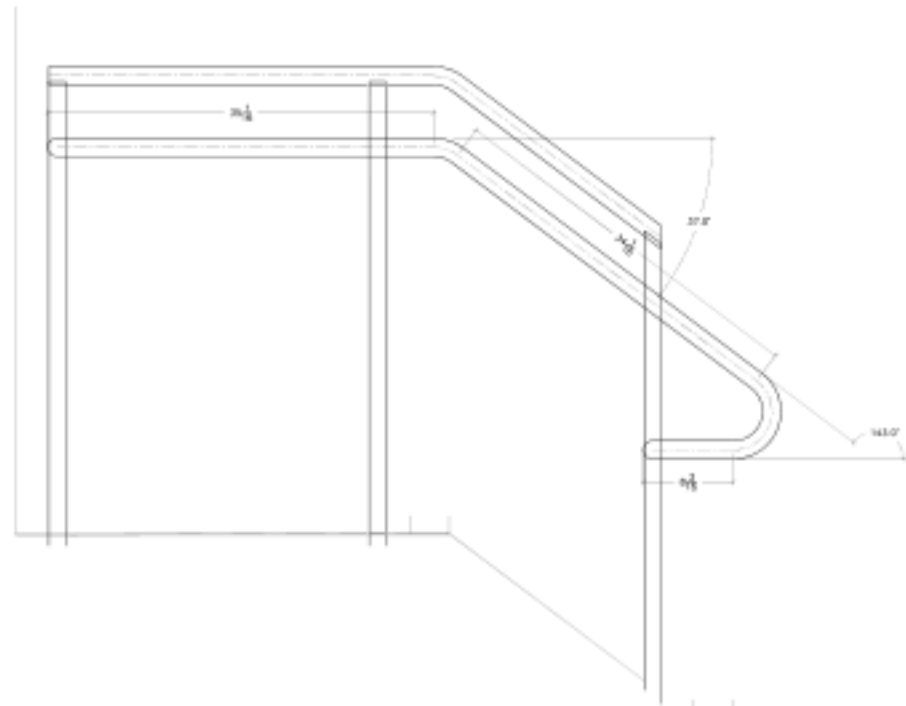

I

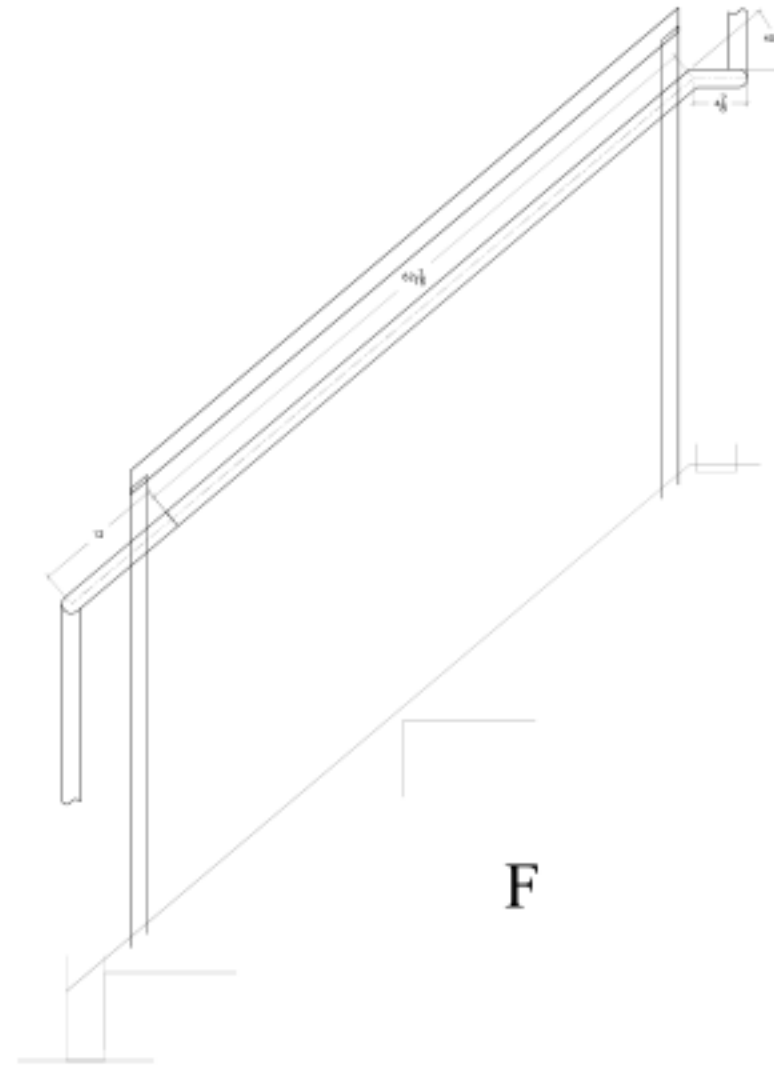

F

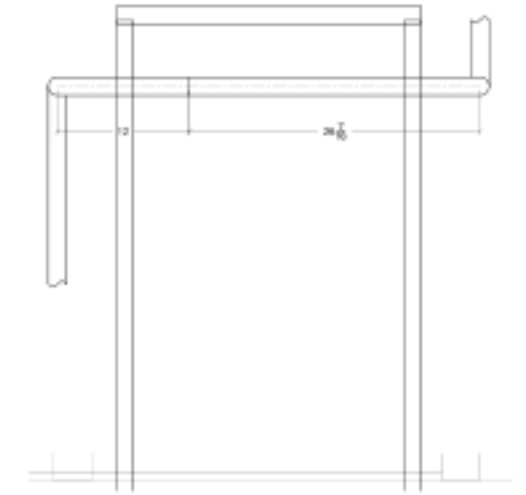

E

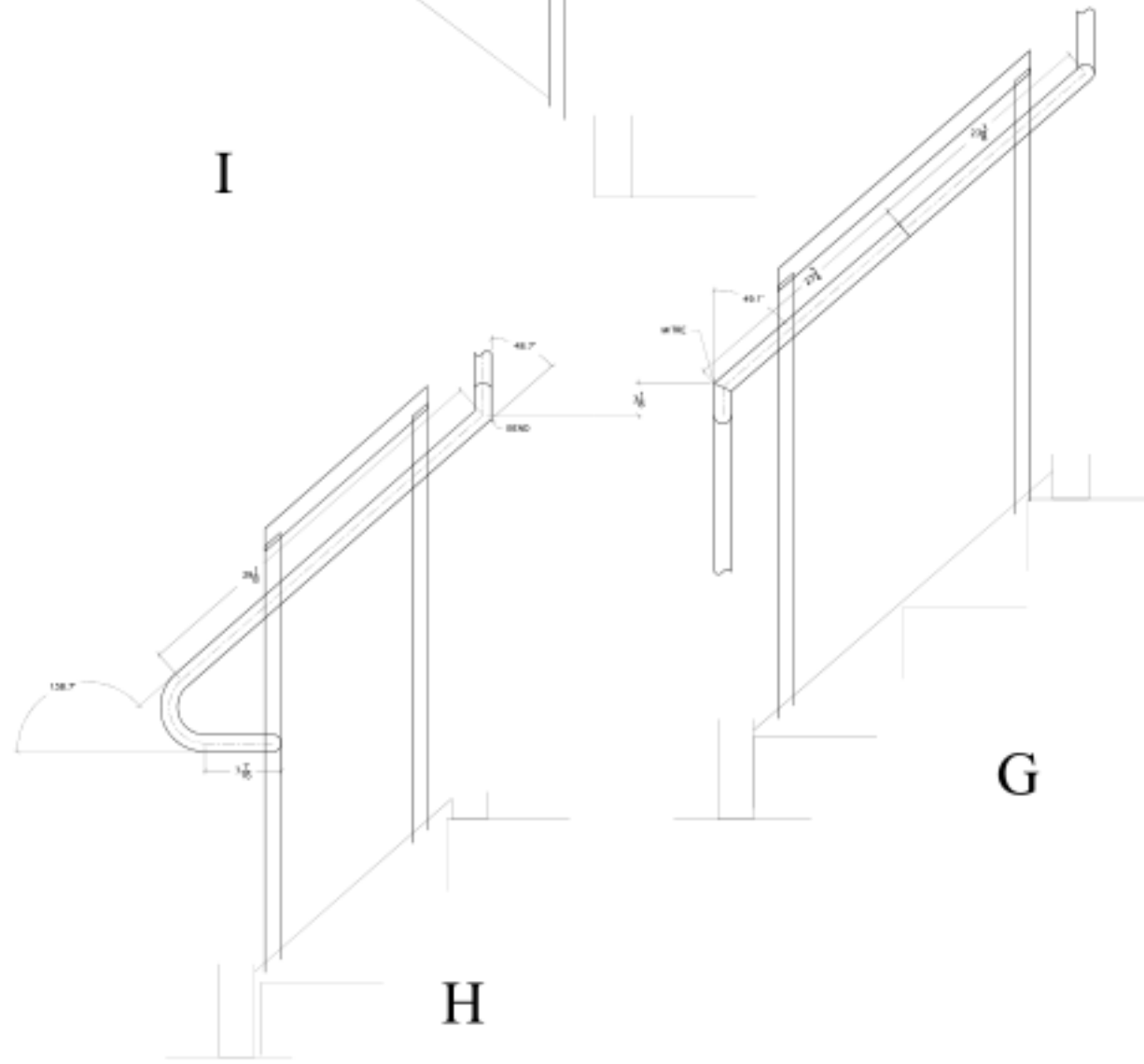

H

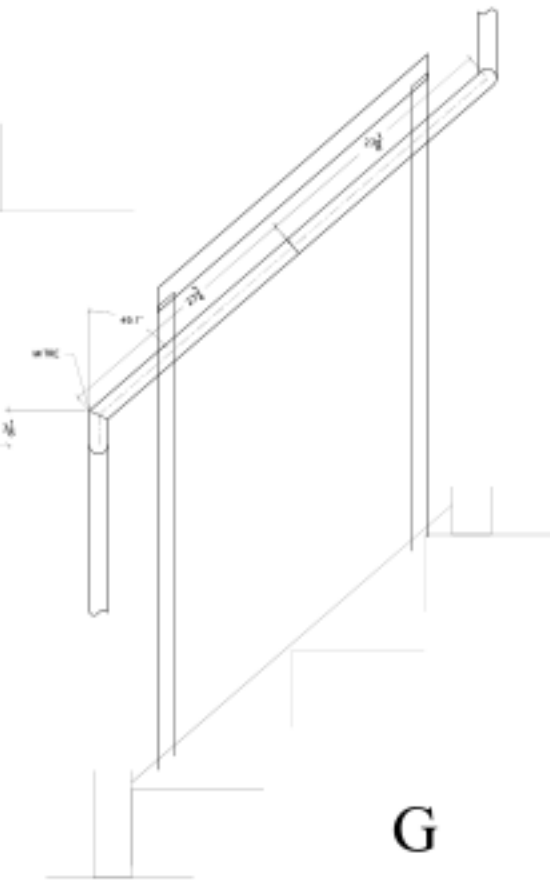

G

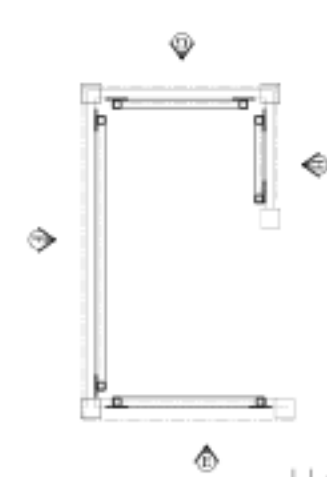
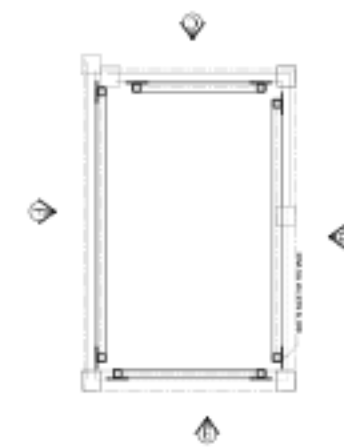
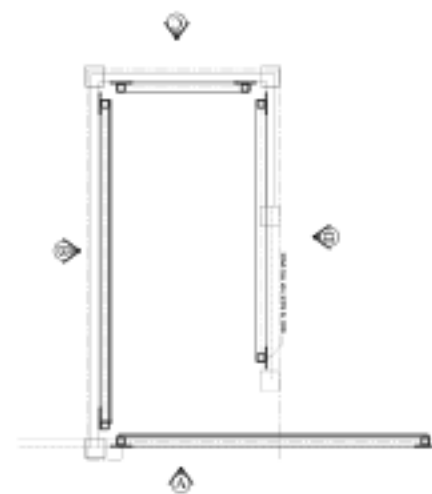

MATERIALS:
 POSTS 1 1/2" SQ TUBE
 GUARD TOP RAIL 1 1/2" SCH 40
 HANDRAIL 1 1/2" SCH 40
 PICKETS 3/4" ROUND BAR

HANDRAILS E-I

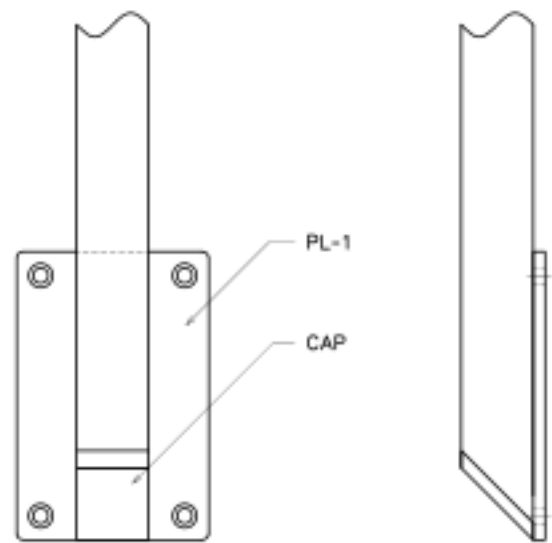

BP-CONFIG-1
QTY 7

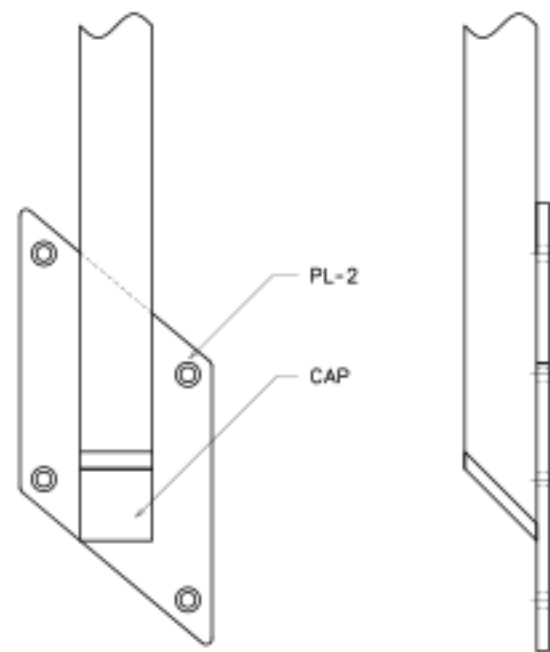

BP-CONFIG-2
QTY 9

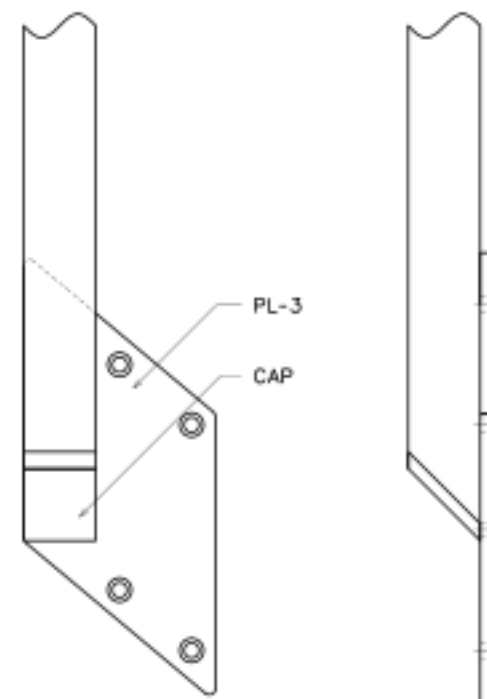

BP-CONFIG-3
QTY 2

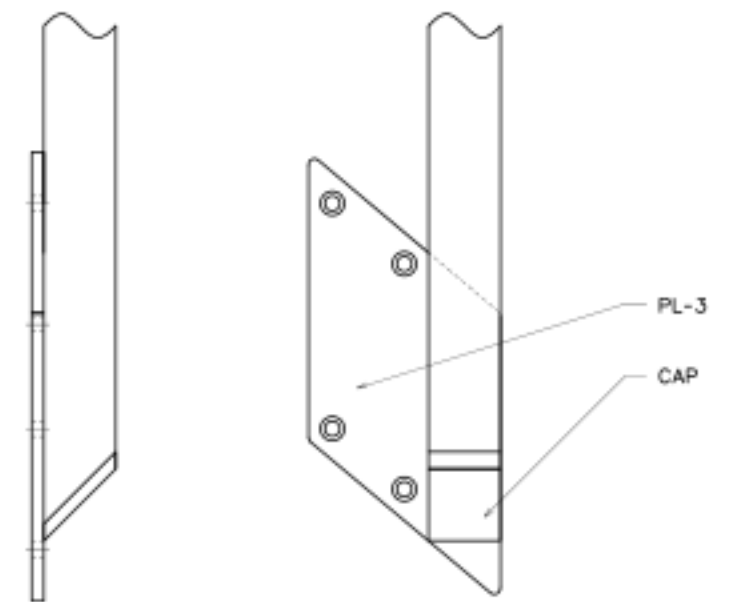

BP-CONFIG-4
QTY 1

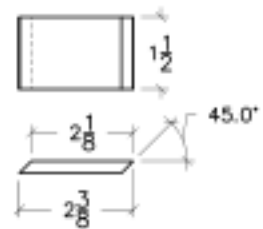

CAP
1 1/2 X 2 1/4 FLAT
QTY 19

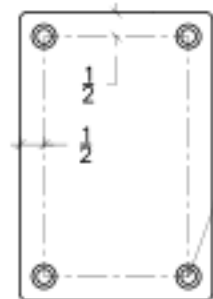

PL-1
4 X 6 X 1/4
QTY 7

Ø 5/16 C.S. HOLES FOR
#14 F.H. SCREWS

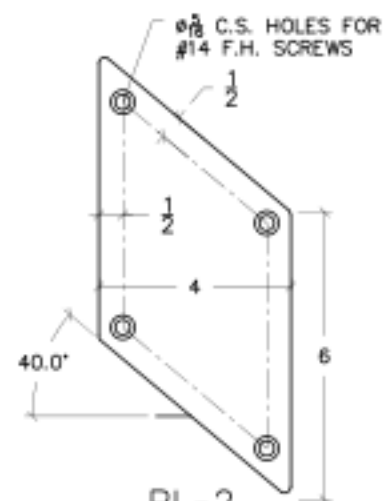

PL-2
4 X 1/4 FLAT
QTY 9

Ø 5/16 C.S. HOLES FOR
#14 F.H. SCREWS

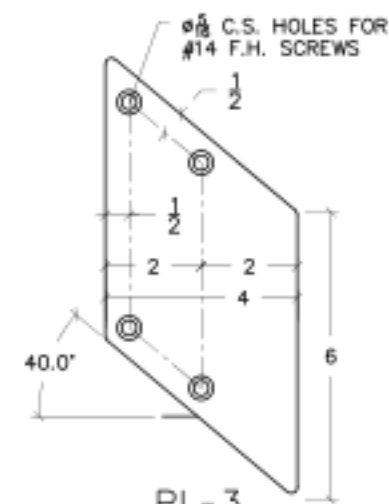

PL-3
4 X 1/4 FLAT
QTY 3

Ø 5/16 C.S. HOLES FOR
#14 F.H. SCREWS

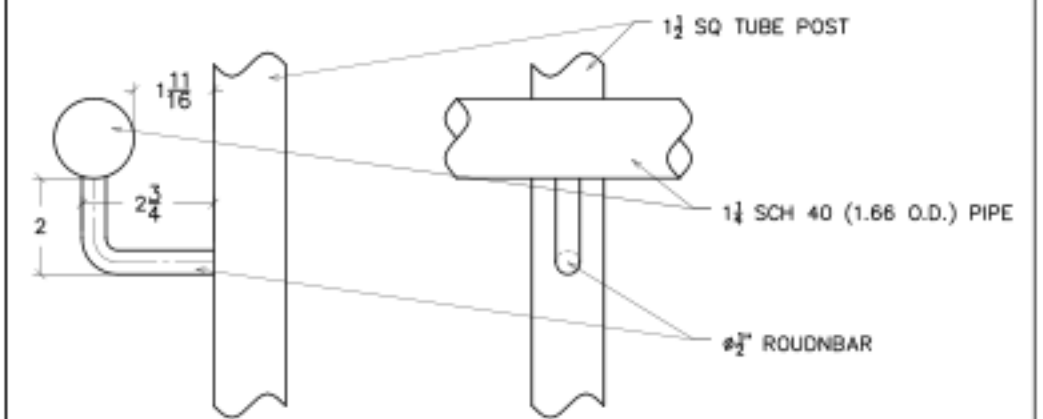

DETAILS

